

1 SECTION THROUGH BUS HOIST
S2.3 S4.2 1:20

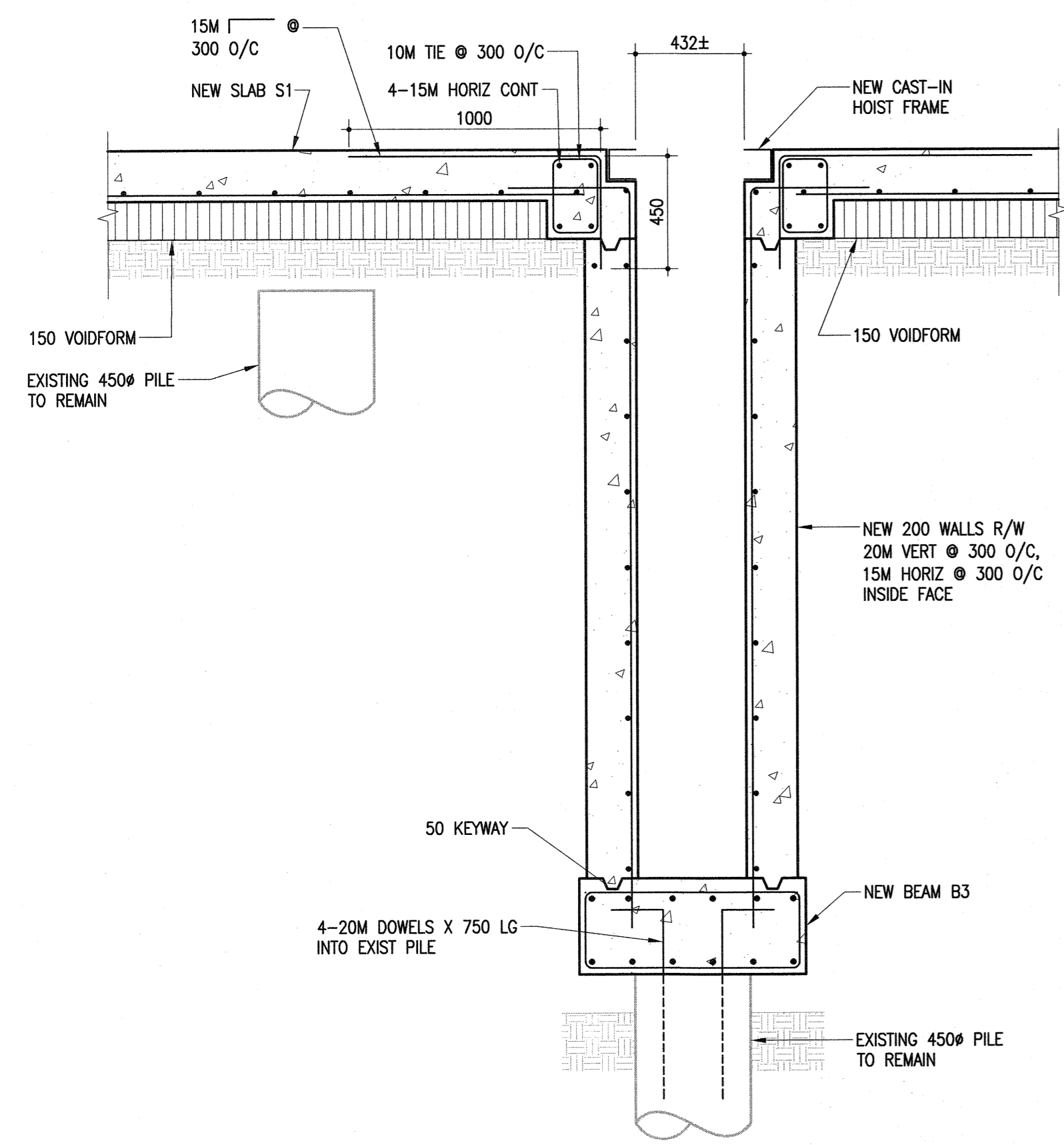

2 SECTION THROUGH SIDE PIT
S2.2 S4.2 1:20

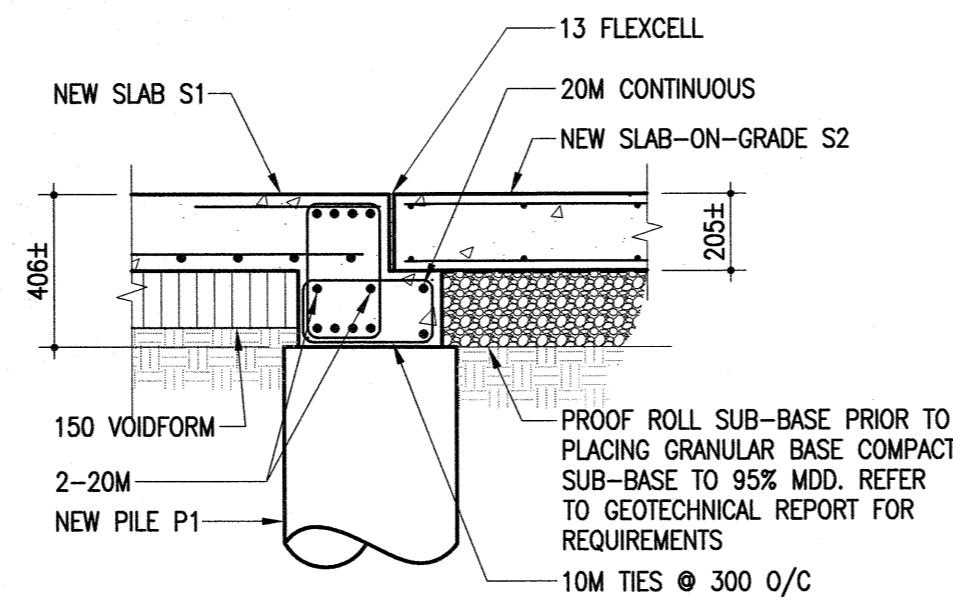

3 JOINT SECTION
S2.2 S4.2 1:20

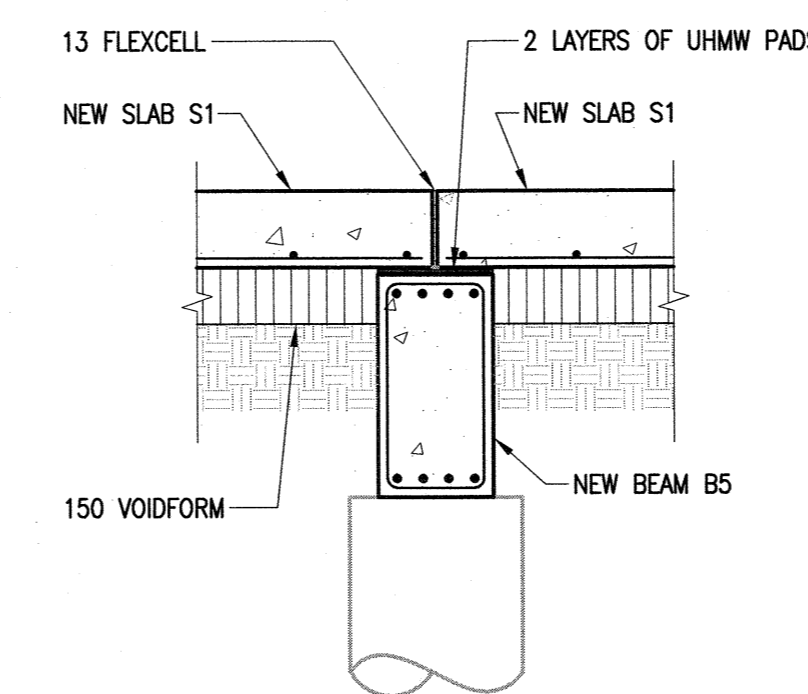

4 EXPANSION JOINT SECTION
S2.2 S4.2 1:20

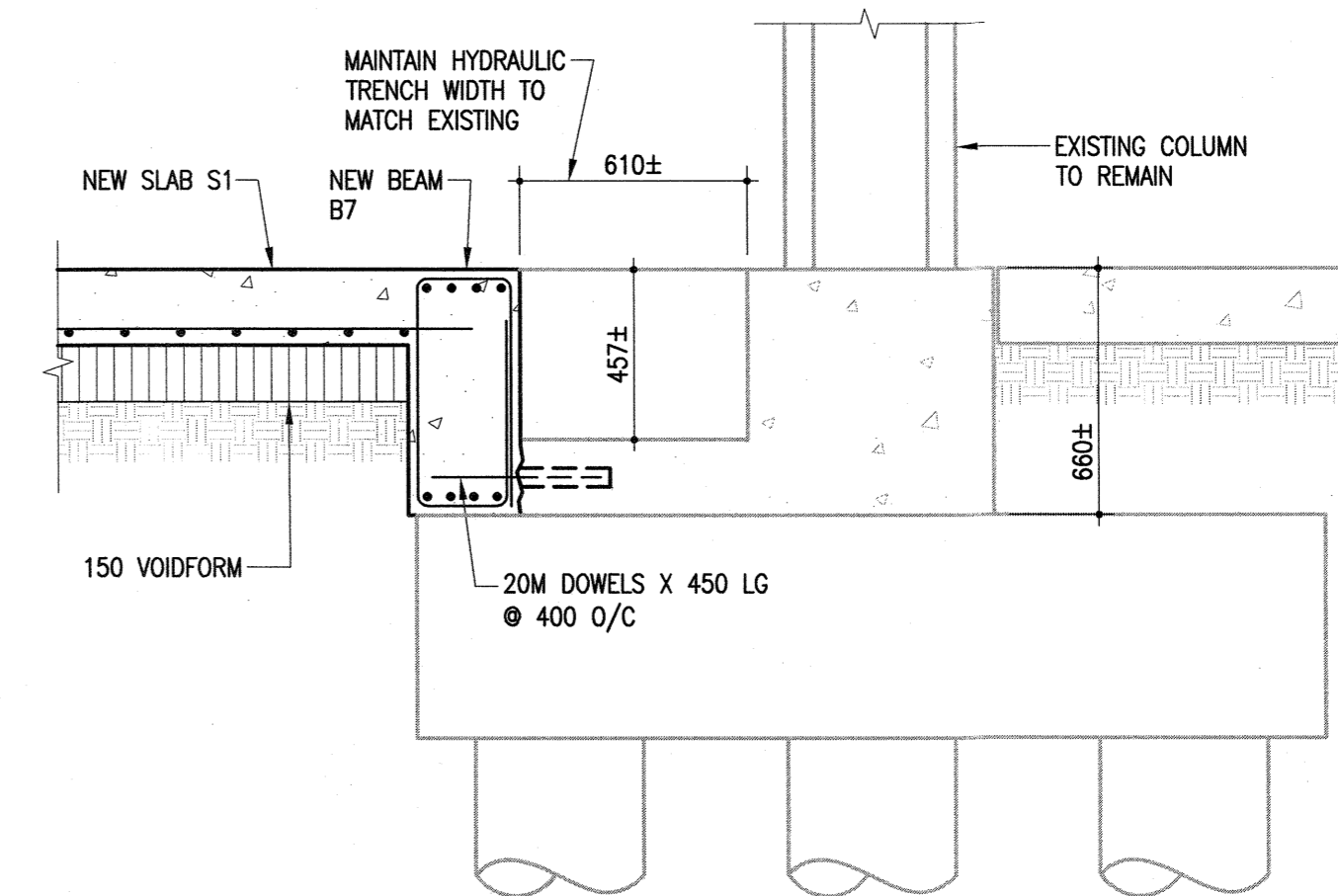

5 HYDRAULIC TRENCH SECTION
S2.2 S4.2 1:20

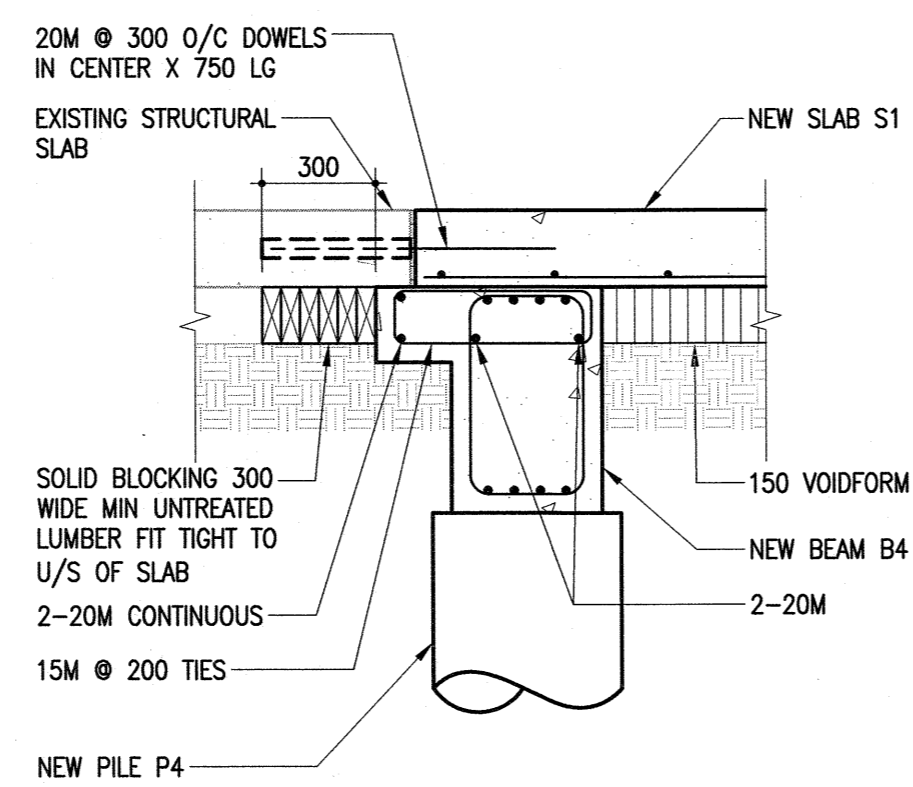

6 NEW - EXIST JOINT SECTION
S2.2 S4.2 1:20

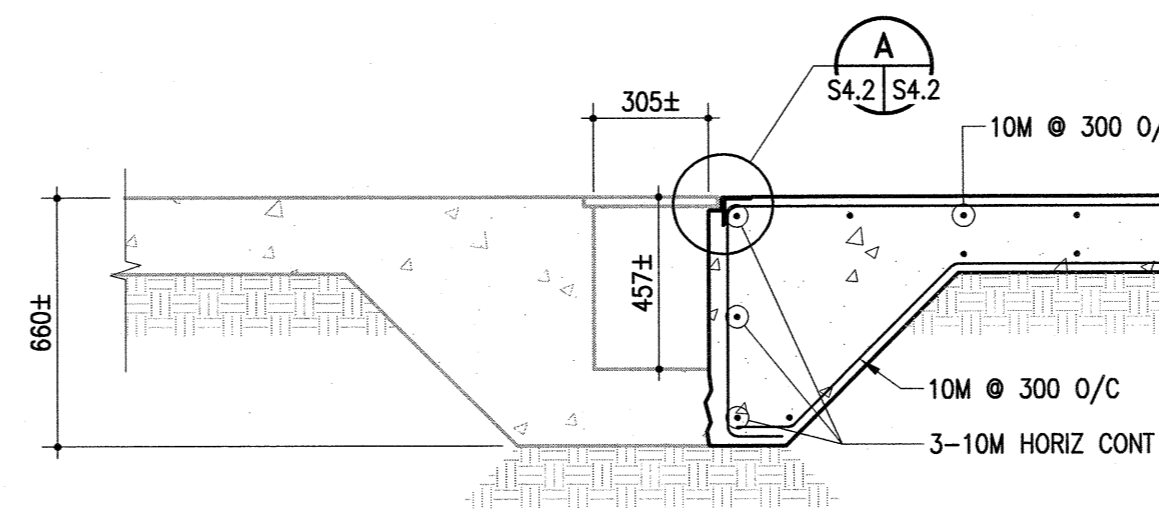

7 NEW - DRAINAGE TRENCH SECTION
S2.2 S4.2 1:20

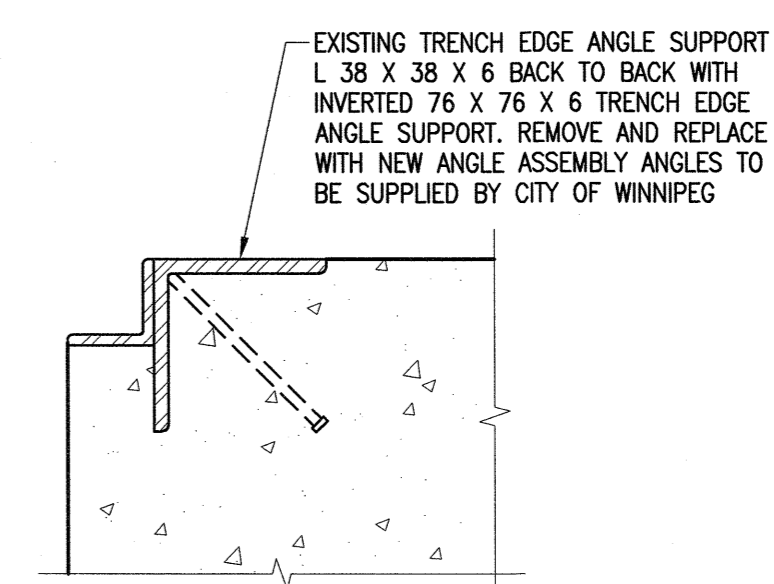

A SECTION
S4.2 S4.2 1:10

The General Contractor shall check & verify all dimensions and report any errors or omissions to the designers.

No.	Date	Issue/Revision	By
1	2019-08-30	ISSUED FOR CONSTRUCTION	IM
0	2019-08-21	ISSUED FOR BID	IM

ENGINEERS GEOSCIENTISTS MANITOBA
Certificate of Authorization
Crosier Kilgour & Partners Ltd.
No. 235



Consultant

300-275 Carlton Street
Winnipeg, Manitoba R3C 5R6
T 204-943-7501
F 204-943-7507

Crosier Kilgour & Partners Ltd.
CONSULTING STRUCTURAL ENGINEERS

Project
WINNIPEG TRANSIT GARAGE BUILDING
HOIST REPLACEMENT PROGRAM
421 OSBORNE STREET
WINNIPEG, MANITOBA

Sheet Title
NEW DETAILS

File	Date
2018-1170	2019-08-30

Design	Drawn
IM	JSR

Revision	Sheet No.
1	S4.2