

NO.	SYMBOL	MESSAGE	DIMENSIONS (W x H)	MESSAGE & BORDER	BACKGROUND	NO. OF SYMBOLS	SPECIAL INSTRUCTIONS
1	BB-71	PERMIT REQUIRED	300 x 450	BLACK	WHITE	8	CENTRE UPON ACCESSIBLE PARKING SPACE
2	UNAUTHORIZED	UNAUTHORIZED PARKING PROHIBITED	750 x 750 SQUARE	BLACK & BLACK	WHITE	14	SMALL LETTERING 50mm HIGH LARGE LETTERING 75mm HIGH
3	UNAUTHORIZED	VISITOR PARKING STALLS 000-000	750 x 750 SQUARE	BLACK & BLACK	WHITE	2	NO. TYPE 2 TO BE ADDED ABOVE ALL SIGN TYPE 2'S
4	UNAUTHORIZED	SMALL CAR ONLY	300 x 300 SQUARE	BLACK & BLACK	WHITE	2	SEE DETAIL #4 WHERE SIGN IS TO BE ATTACHED TO EXISTING LIGHT POLE
5	UNAUTHORIZED	NO PARKING	300 x 300 SQUARE	BLACK & BLACK	WHITE	12	
6	UNAUTHORIZED	LOADING ZONE	300 x 300 SQUARE	BLACK & BLACK	WHITE	301	SMALL LETTERING 50mm HIGH LARGE LETTERING 75mm HIGH
7	UNAUTHORIZED	LOADING ZONE	300 x 300 SQUARE	BLACK & BLACK	WHITE	1	

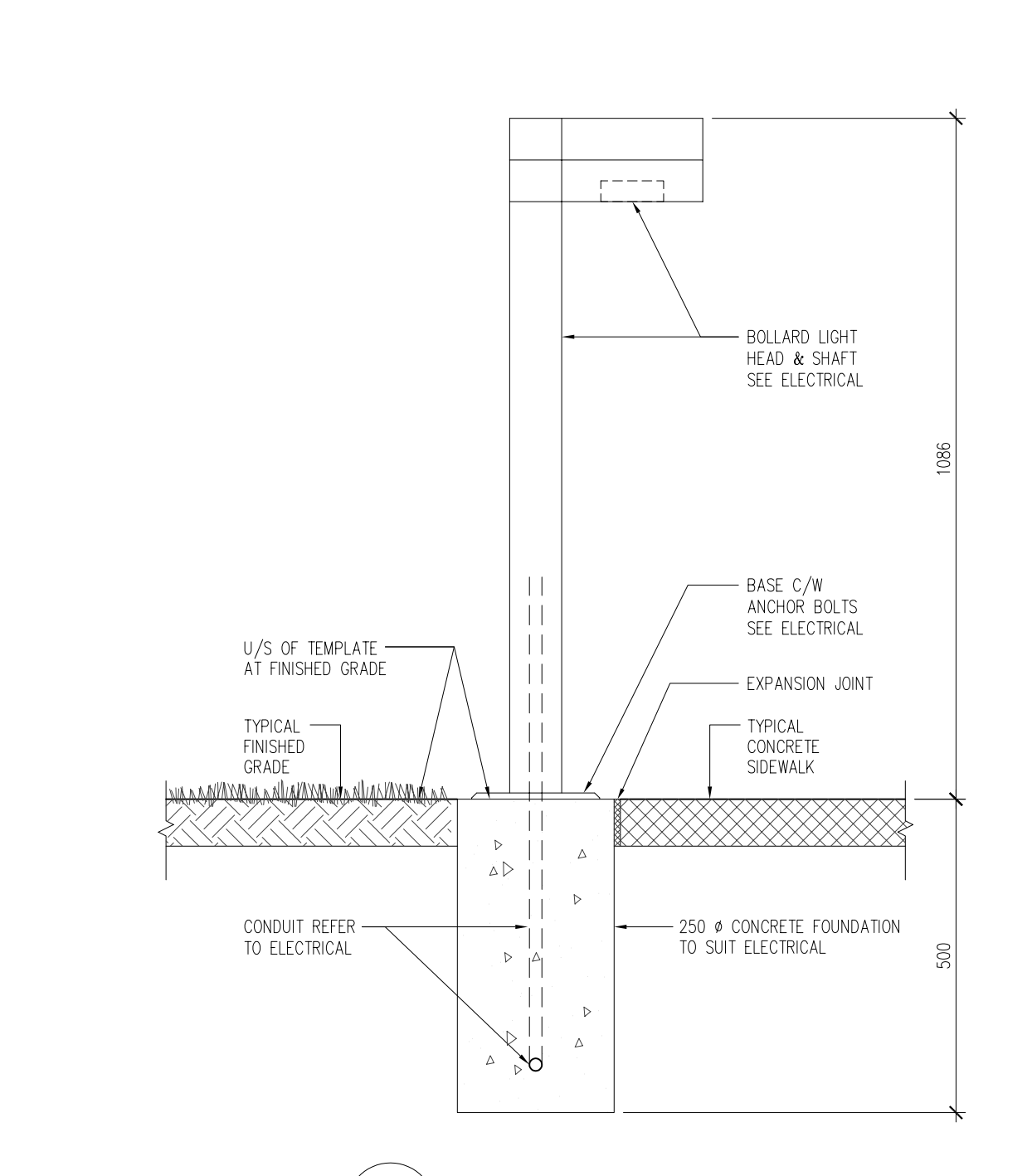
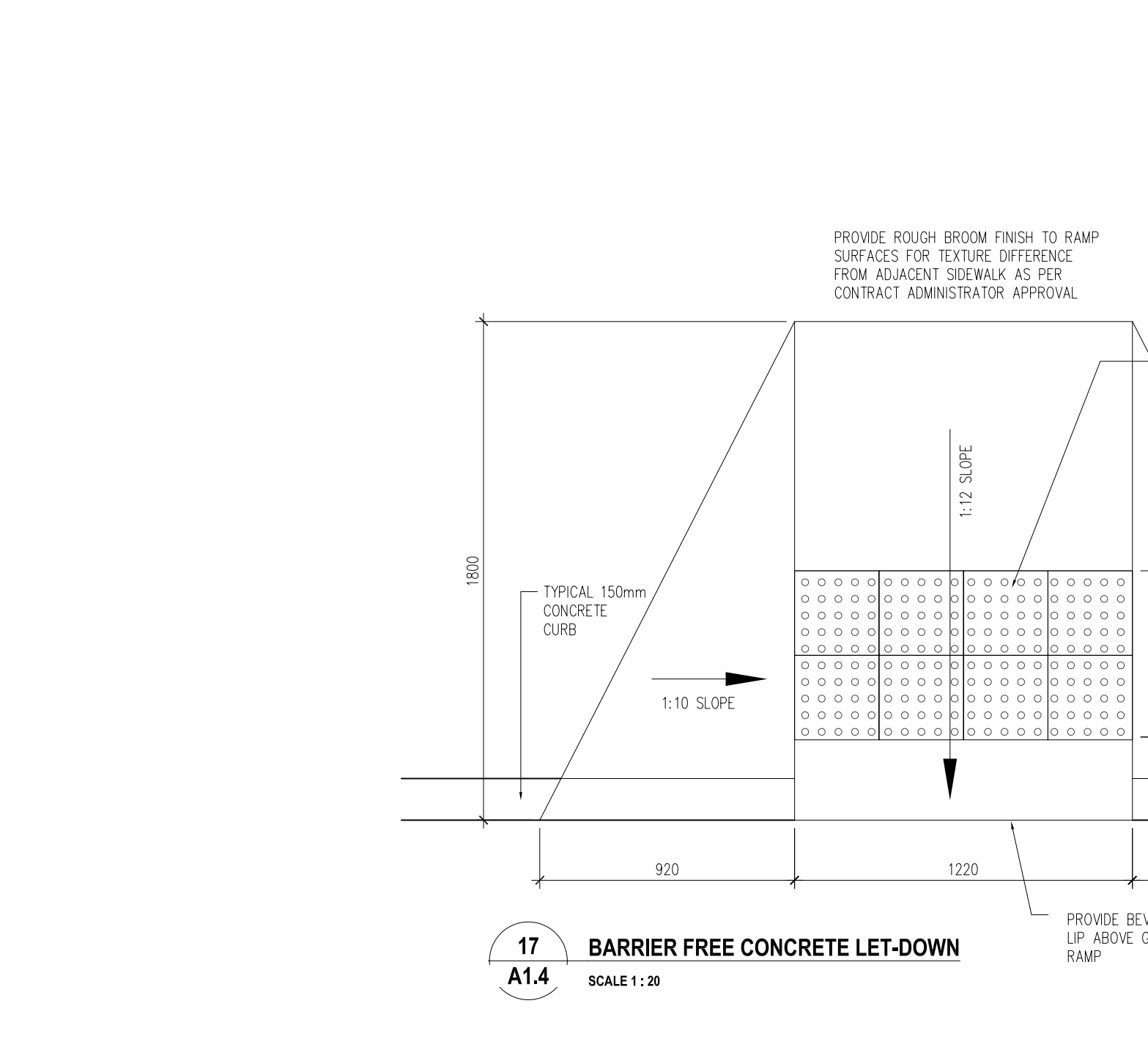
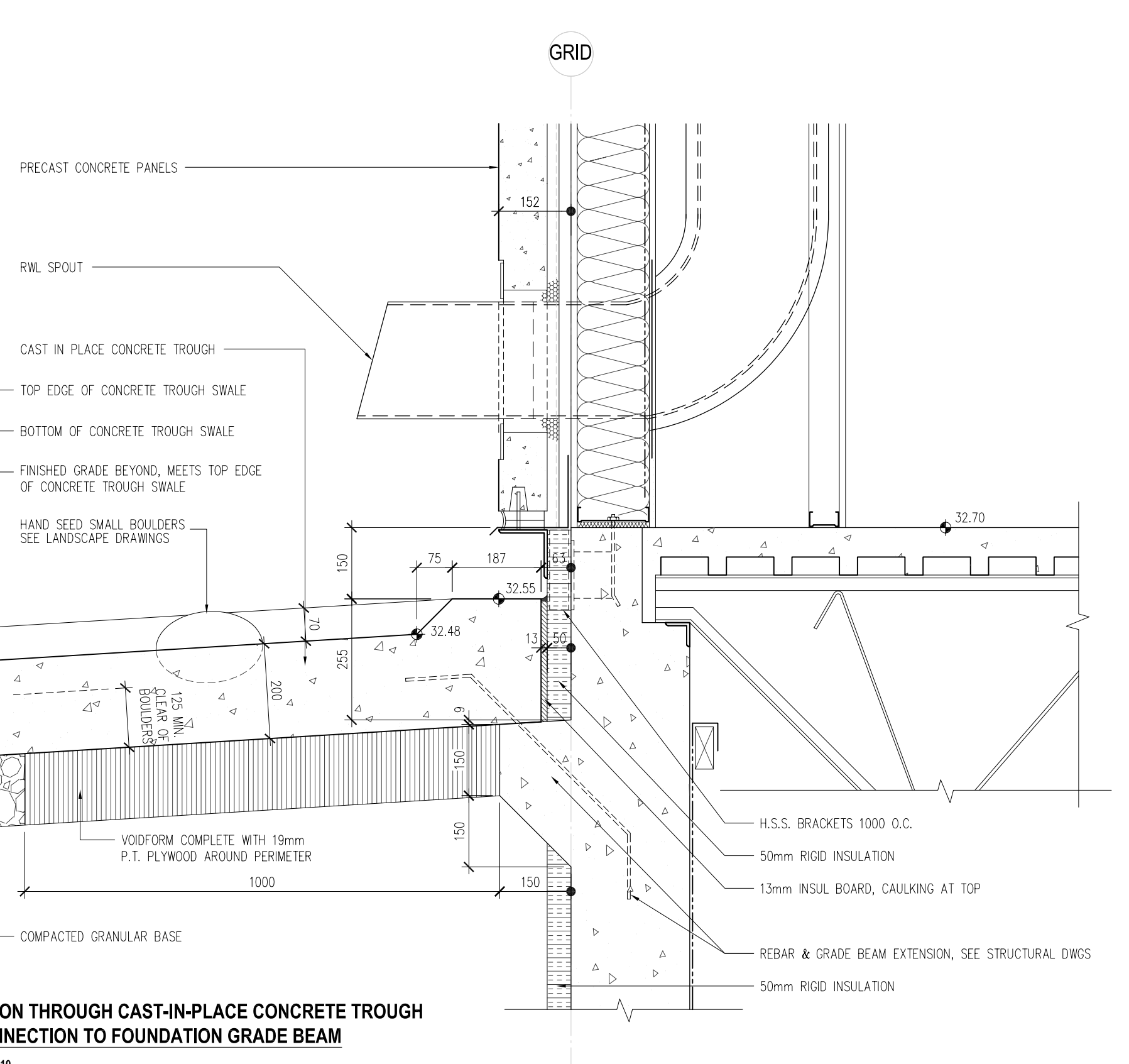
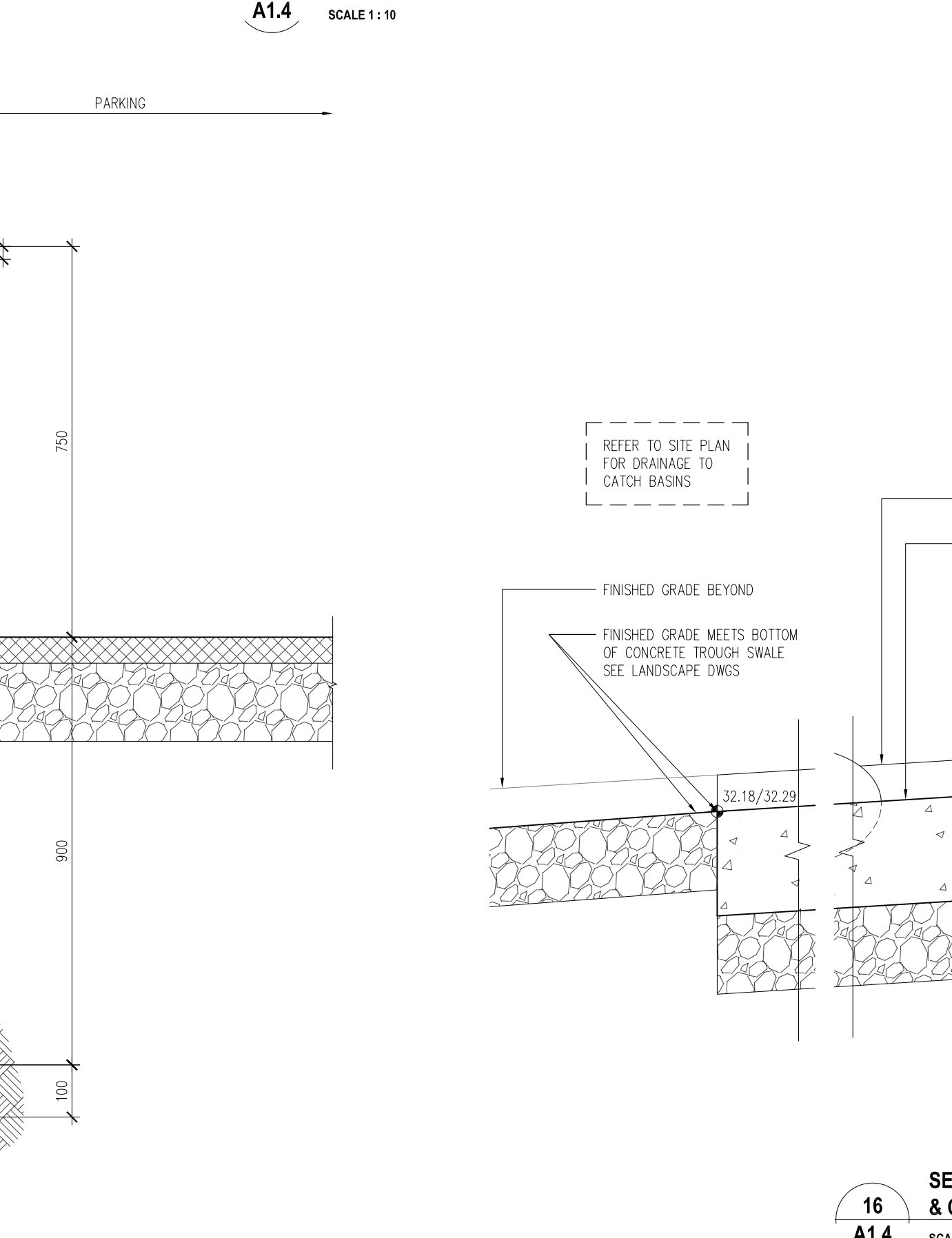
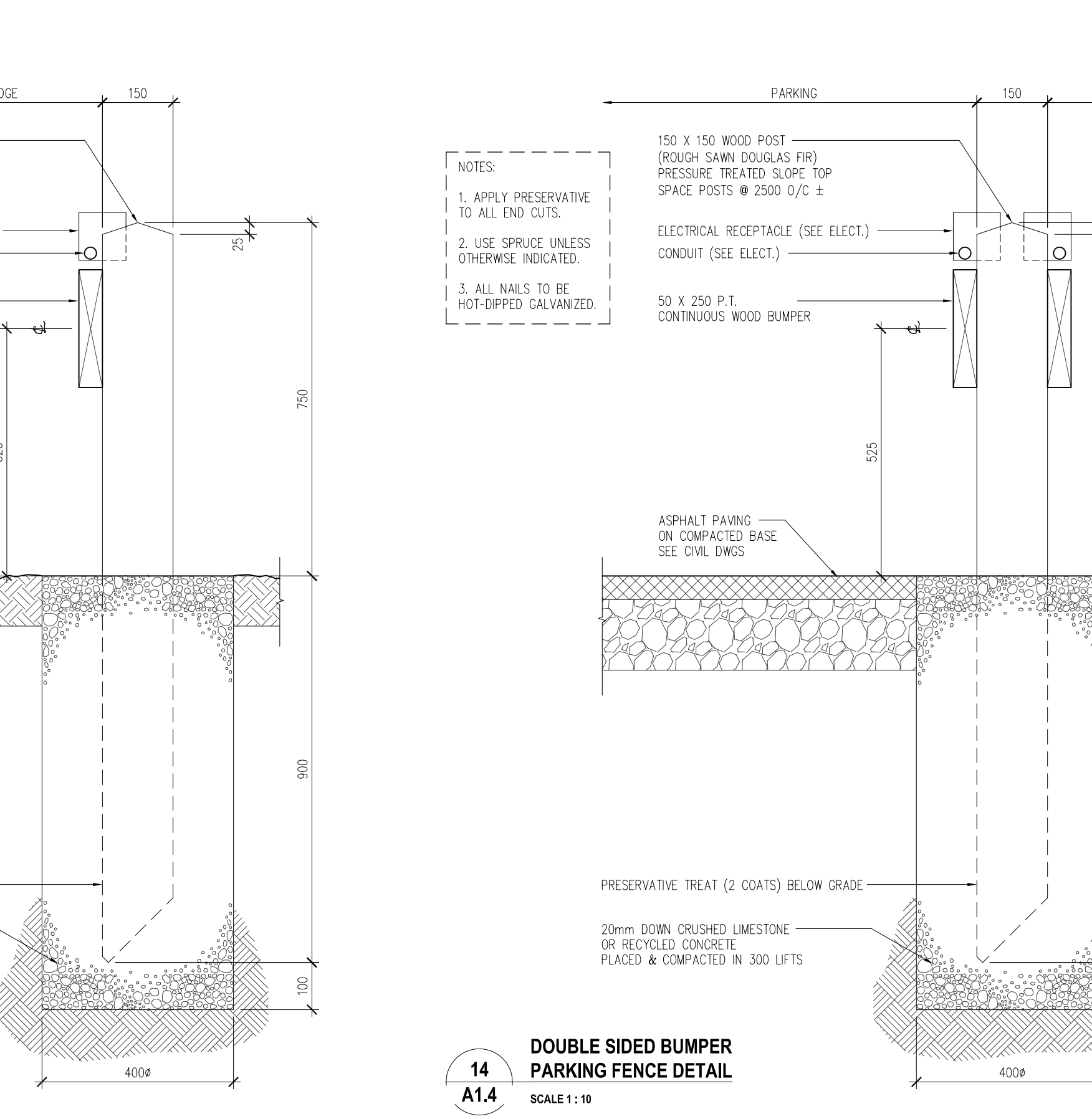
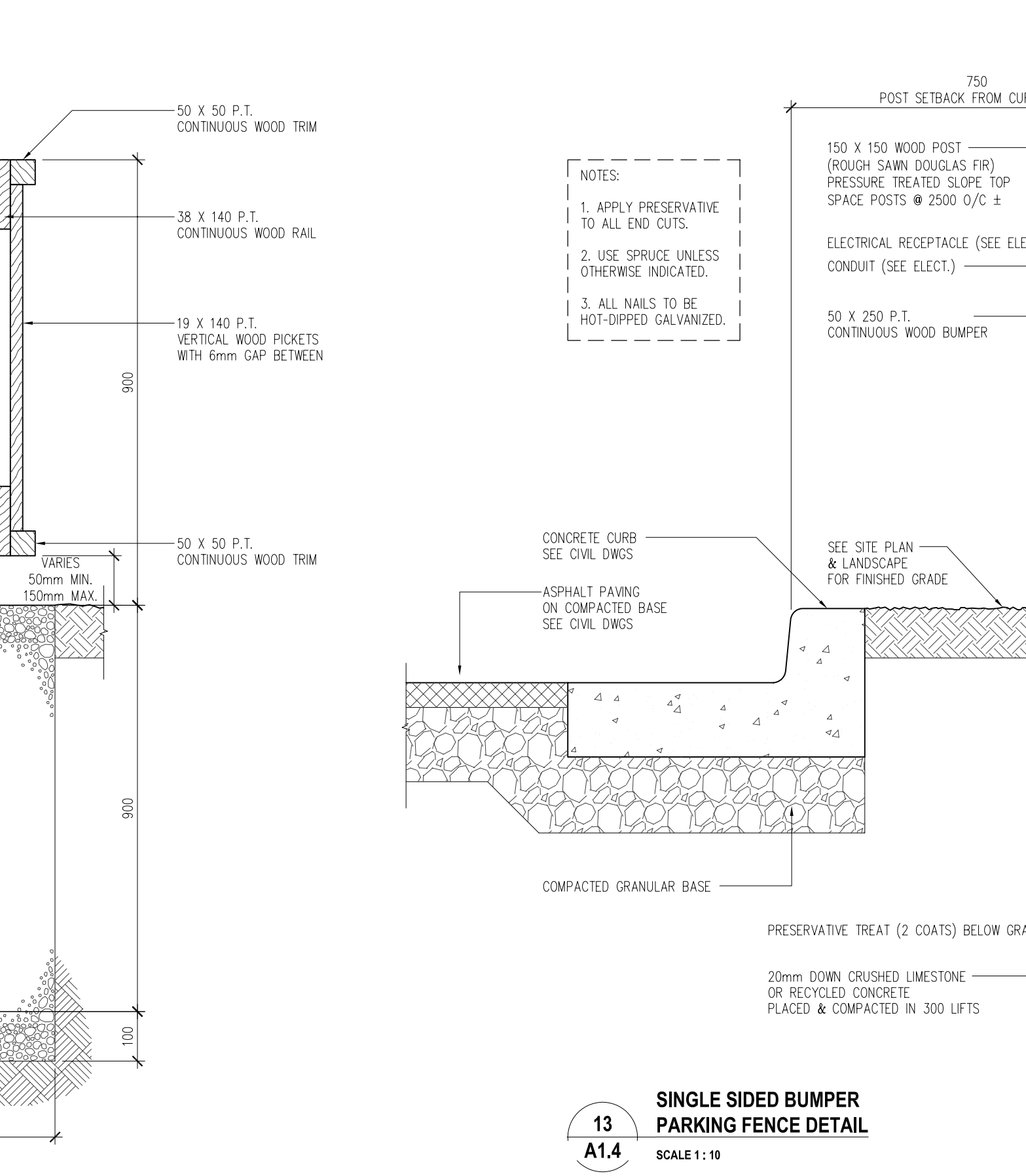
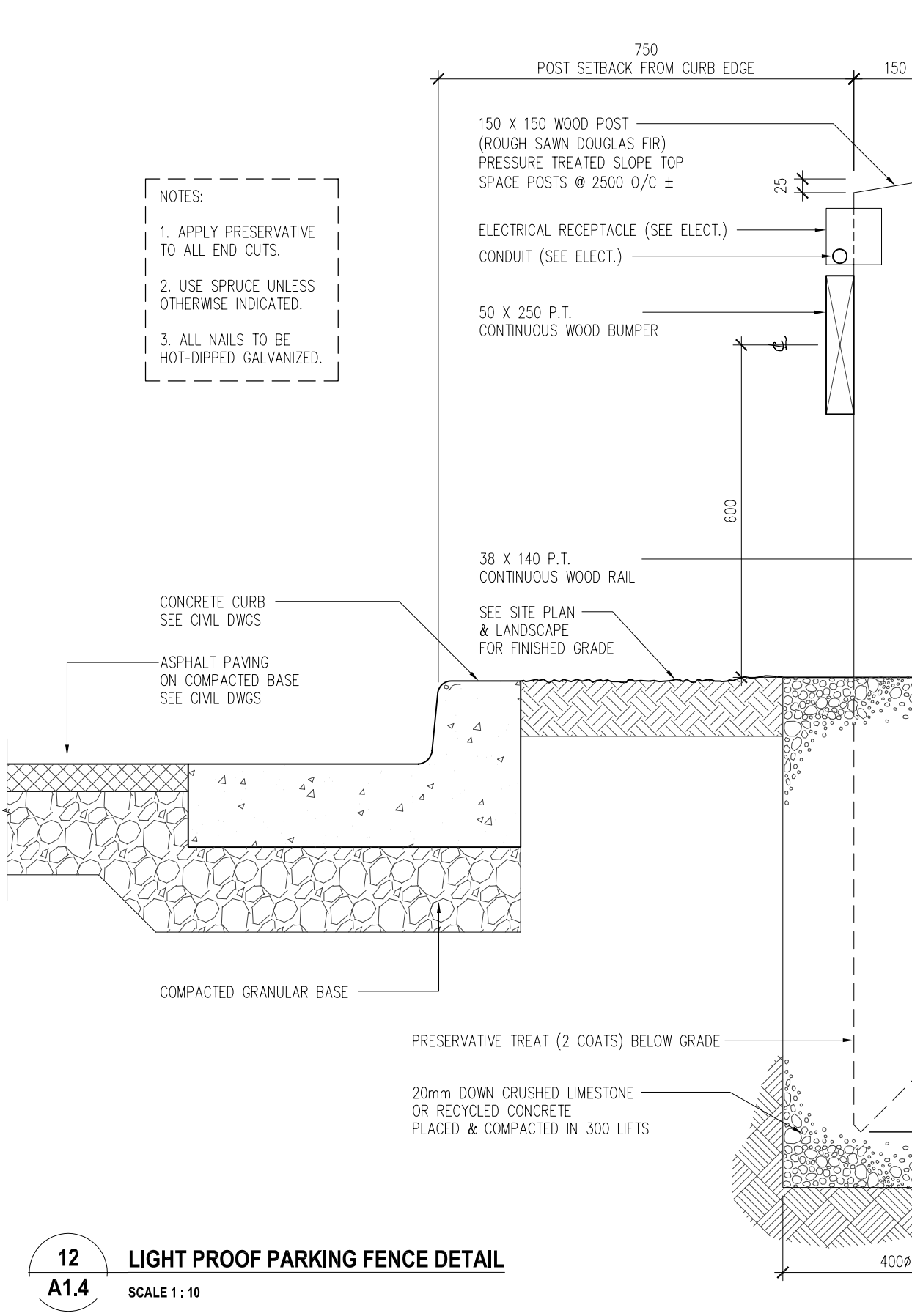

Drawings and specifications, as instruments of service are the property of the architect. The copyright in the same being reserved to him. No reproduction may be made without the permission of the architect and when made, must bear his name. The contractor shall verify dimensions and shall retain them with conditions on the job and is held responsible for reporting any discrepancy to the architect for adjustment. This drawing shall not be used for building purposes until counterchecked by:

THE CITY OF WINNIPEG

OFFICE ADDITION AND RENOVATION
 1155 PACIFIC AVENUE
 WINNIPEG, MANITOBA

FRIESEN TOKAR ARCHITECTS

SITE PLAN DETAILS
A1.4