

TYPICAL ROAD X-SECTION
SCALE: 1:50

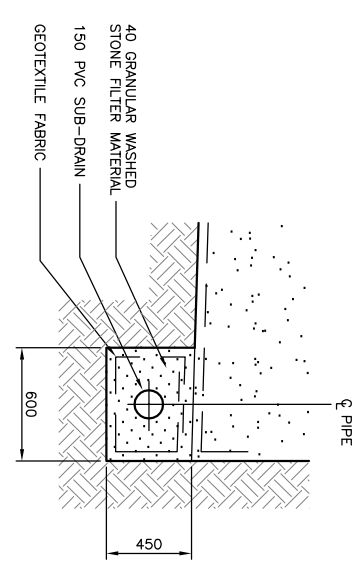

SUB-DRAIN DETAIL
SCALE: 1:20

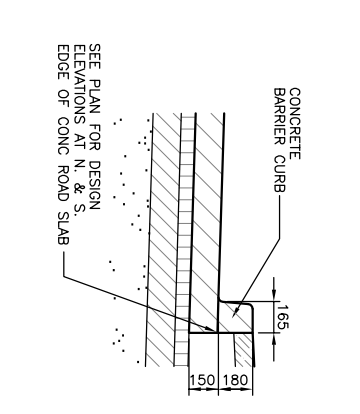

CONCRETE CURB DETAIL
SCALE: 1:20

EXISTING	LEGEND-PLAN	PROPOSED	LEGEND-PLAN	PROPOSED	LEGEND-PROFILE	PROPOSED
○	MAHOLE	○	PROPERTY LINE	○	N. SIDEWALK	○
○	CATCH BASIN	○	SURVEY BAR	○	SOUTH TREE LINE	○
○	CURB INLET	○	GEOLOGIC BENCHMARK ELEVATION	○	N/W LANE EDGE	○
○	LEGEND-PLAN	○	PROPOSED	○	PARKING/DRIVEWAY WINDOW/DOOR SILL	○
○	LEGEND-PLAN	○	PROPOSED	○	LEGEND-PROFILE	○

LOCATION APPROVED UNDERGROUND STRUCTURES

NOTE: UNDERGROUND STRUCTURES AS SHOWN ARE APPROVED FOR CONSTRUCTION PROVIDED THAT THE EXISTING UTILITIES ARE SHOWN OR LOCATED BY THE CONTRACTOR AND EXIST BEFORE PROCEEDING WITH CONSTRUCTION.

NO.	REVISIONS	DATE	BY	DATE
0	ISSUED FOR TENDER	13/09/04	RAH	

KGS CONSULTING ENGINEERS & PROJECT MANAGERS

DESIGNED BY: B.S.
DRAWN BY: D.W.
HQR. SCALE: 1:250
VERTICAL: 1:10

CHECKED BY: C.R.
APPROVED BY: R.J.H.

M.C. ROYTHAM
REGISTERED PROFESSIONAL ENGINEER

THE CITY OF WINNIPEG
PUBLIC WORKS DEPARTMENT
ENGINEERING SERVICES DIVISION

PROJECT TITLE: 2004 LOCAL STREET RENEWALS
BURROWS AVE. WEST BOUND
ARLINGTON ST. TO MCGREGOR ST.
STA. 4+00 TO STA. 5+50

ENGINEER'S SEAL: No. 246 Expiry: April 30, 2004

SHEET 03 OF 04
COMPUTER FILE NAME: 03-107-12
CITY DRAWING NUMBER:

APGIN
Certificate of Authorization
KGS Group

PRELIMINARY
NOT TO BE USED FOR CONSTRUCTION

WARNING

F. POWER EQUIPMENT OR EXPLOSIVES ARE TO BE USED FOR EXCAVATION ON THIS PROJECT THE CONTRACTOR SHALL NOTIFY THE GAS COMPANY OF THE PROPOSED LOCATION OF EXCAVATION.
2. TAKE PRECAUTION OF AVOID DAMAGE TO GAS COMPANY SERVICE LINE. REGULATION 210/72 FOR DETAILS.

METRIC
WHOLE NUMBERS INDICATE MILLIMETRES
DECIMALIZED NUMBERS INDICATE METRES

SCALE: 1:250 METRIC A1
SCALE: 1:500 METRIC A3