

**PART E**  
**SPECIFICATIONS**

## **PART E - SPECIFICATIONS**

### **GENERAL**

#### **E1. APPLICABLE SPECIFICATIONS, STANDARD DETAILS AND DRAWINGS**

- E1.1 *The City of Winnipeg Standard Construction Specifications* in its entirety, whether or not specifically listed on Form B: Prices, shall apply to the Work.
- E1.1.1 *The City of Winnipeg Standard Construction Specifications* is available in Adobe Acrobat (.pdf) format on the Information Connection page at The City of Winnipeg, Corporate Finance, Materials Management Division internet site at <http://www.winnipeg.ca/matmgt>.
- E1.1.2 The version in effect three (3) Business Days before the Submission Deadline shall apply.
- E1.1.3 Further to GC:2.4(d), Specifications included in the Bid Opportunity shall govern over *The City of Winnipeg Standard Construction Specifications*.
- E1.2 The following Drawings are applicable to the Work:

<u>Drawing No.</u>	<u>Drawing</u>
L0	Cover Sheet
L1	South Entry to Westview Park
L2	Hilltop Viewing Area and Orientation Node
L3	South Point and Hilltop Viewing Area Details
L4	Toboggan Hill and Snowboard Terrain Park

#### **E2. DAMAGE TO EXISTING STRUCTURES AND PROPERTY**

- E2.1 Further to Clause GC6.28(a) of the General Conditions, special care shall be taken to avoid damage to existing adjacent structures and properties during the course of the Work.
- E2.2 Any damage caused by the Contractor or his Subcontractors to the adjacent structures or properties shall be promptly repaired by the Contractor at his own expense to the satisfaction of the Contract Administrator.

#### **E3. SITE PREPARATION, REMOVALS & SALVAGE**

##### **E3.1 GENERAL**

- E3.1.1 Description
- (a) This Specification shall cover all aspects of the Site Preparation, Removals and Salvage Work as described by Drawings, including, but not limited to the following:
    - (i) equipment mobilization and demobilization
    - (ii) erection and maintenance of safety fence
    - (iii) removal and disposal of pre-cast parking curbs, wooden bollard, bollard chain, waste receptacle, drinking fountain, tree, bench base, pre-cast patio pavers, PVC pipe, and chain link fencing
    - (iv) excavation of granular path
    - (v) salvage and stockpiling of bike stand, sign, waste receptacles, picnic table, and chain link fencing
    - (vi) construction access

**E3.2 EXECUTION**

**E3.2.1 Mobilization and Demobilization**

- (a) The mobilization and demobilization of all equipment necessary to complete the Work is covered under this Specification.

**E3.2.2 Site Access**

- (a) The location of access points for the construction equipment and materials, and the methodology to facilitate construction shall be subject to the approval of the Contract Administrator.
- (b) Care shall be taken to prevent damage to existing trees, site facilities, services and roads. In the event of damage to existing site facilities or services caused by the Contractor's access and construction activities, the Contractor shall be held liable, and shall be required to provide appropriate restoration, to the satisfaction of the Contract Administrator.

**E3.2.3 Removals and Salvage**

- (a) The Contractor shall load and haul all removed materials away from the Site, and dispose of these materials at dumps located by the Contractor and approved by the Contract Administrator. All removed material shall be disposed off Site immediately upon collection.
- (b) Removals shall be conducted as described by Drawings and include:

No.	Removal	Qty
	Area 1: South Entry	
1	Pre-Cast Parking Curbs	3
2	Wooden Bollard	1
	Area 2: Hilltop Viewing Area and Orientation Node	
1	Bollard Chain	1 section
2	Granular Path	400 M2
3	Waste receptacles	2
4	Drinking fountain (base, water lines & fixtures)	1
5	Tree	1
6	Bench base	1
7	Pre-cast patio pavers	5
8	PVC pipe	1
	Area 3: Toboggan Slide and Terrain Park	
1	Chain Link Fencing	35 LM

- (c) Salvaged materials shall be stockpiled on site in areas approved by Contract Administrator. Care shall be taken to protect existing trees when stockpiling material, as per Specification E4 – “Protection of Existing Trees”.
- (d) Materials to be salvaged as described by Drawings and include:

No.	Salvage	Qty
	Area 1: South Entry	
2	Bike stand	1
3	Sign	1
4	Waste Receptacle	1
	Area 2: Hilltop Viewing Area and Orientation Node	
1	Waste receptacles	1
2	Picnic table	1
	Area 3: Toboggan Slide and Terrain Park	
1	Chain Link Fencing	20 LM

**E3.3 METHOD OF MEASUREMENT**

(a) No measurement shall be made for site preparation, removals and salvage.

**E3.4 BASIS FOR PAYMENT**

(a) Site preparation, removals and salvage will be paid for at the Contract Lump Sum Price for each "Items of Work", listed below, which price shall be payment in full for supplying all materials and performing all operations herein described and all other items incidental to the Work included in this Specification.

Items of Work:

- (i) Site Preparation, Removals & Salvage – Area 1
- (ii) Site Preparation, Removals & Salvage – Area 2
- (iii) Site Preparation, Removals & Salvage – Area 3

**E4. PROTECTION OF EXISTING TREES**

**E4.1 GENERAL**

**E4.1.1 Description**

(a) This specification covers the protection of all existing trees, other than trees to be removed as described by Drawings. The Work to be done by the Contractor under this Specification shall include the furnishing of all superintendence, overhead, labour, materials, equipment, tools, supplies and all other things necessary for and incidental to the satisfactory performance and completion of all Work hereinafter specified.

**E4.2 EXECUTION**

**E4.2.1 Preservation**

(a) Existing trees, other than trees to be removed as identified by Drawings, shall be protected and preserved as is.

**E4.2.2 Trunk Protection**

(a) All trees will have a 1.0m (minimum) radius protective zone calculated from the circumference at the base of the trunk which will remain free of digging, trenching, grade changes, stock piling of materials and soil compaction throughout the duration of the contract. Protective fencing around these areas is required. All trees within and immediately adjacent to, proposed construction areas will require 1x6x8' wood planks strapped to the tree trunk to completely protect the tree trunk from impact

damage. (smaller trees will be similarly protected using proportionally sized wood planks).

**E4.2.3 Overhead Branch and Limb Protection**

- (a) Tree limbs and branches overhanging the construction area shall not be damaged. The Contractor shall ensure that the above ground portions of trees are not damaged.

**E4.2.4 Excavation**

- (a) During all excavation a representative from the City of Winnipeg Forestry Branch shall be present at all times unless otherwise agreed upon by the Contract Administrator, Forestry Branch and Contractor prior to commencement of construction.

**E4.2.5 Notification**

- (a) The Contract Administrator is to be notified 48 hours in advance of any large equipment to be working in the vicinity of existing trees. The Contractor shall provide adequate personnel on foot to supervise equipment operators in the vicinity of the trees to ensure that no damage occurs.
- (b) Special care is required during excavation to ensure existing tree root structure is not damaged. Should root pruning be required the Contractor must ensure proper root pruning techniques are employed by a licensed arbourist.

**E4.3 METHOD OF MEASUREMENT**

- (a) No measurement will be made for protection of existing trees.

**E4.4 BASIS FOR PAYMENT**

- (a) No separate payment will be made for protection of existing trees.

**E5. EARTHWORK AND GRADING**

**E5.1 GENERAL**

**E5.1.1 Description**

- (a) This specification shall cover all Work associated with Earthwork and Grading at South Entry, Orientation Node, and Terrain Park as described by Drawings. The Contractor shall furnish all superintendence, overhead, labour, materials, equipment, tools, supplies and all things necessary for and incidental to the satisfactory performance and completion of all Work hereinafter specified. This specification shall supplement CW3170-R3 'Earthwork and Grading'.

**E5.2 EXECUTION**

**E5.2.1 General**

- (a) The Contractor shall grade to the levels and contours allowing for surface treatment as shown on Drawings. Existing topsoil shall be stockpiled on-Site as directed by the Contract Administrator. Prior to placing any fill over existing ground the Contractor shall scarify to surface to a depth of 150mm. Moisture content of filling and existing surface material shall be the same in order to facilitate proper bonding.
- (b) All fill shall be clean fill.

**E5.2.2 Compaction**

- (a) Compact fill and undisturbed areas to Standard Proctor Density to ASTM D698-78 as follows:

- (i) Landscaped Areas - 85%
- (ii) Paved Areas - 95%

#### E5.2.3 Approvals

- (a) The Contractor shall stake grades and receive approval from the Contract Administrator prior to any construction.
- (b) The Contract Administrator shall approve grading prior to installation of topsoil and/or surfacing materials.

#### E5.3 METHODS OF MEASUREMENT

E5.3.1 All Earthwork and Grading will be measured on a square meter basis. The amount to be paid for shall be the total number of square metres constructed in accordance with this Specification and as accepted by the Contract Administrator.

#### E5.4 BASIS OF PAYMENT

E5.4.1 Payment for Earthwork and Grading at South Entry, Orientation Node, and Terrain Park shall be paid for at the Contract Unit Price for the "Items of Work" listed below, which price shall include all costs of labour and material supply, including fill, and all other items incidental to the Work included in this Specification.

##### Items of Work:

- (i) Earthwork and Grading – South Entry
- (ii) Earthwork and Grading – Orientation Node
- (iii) Earthwork and Grading – Terrain Park

### E6. GRANULAR SURFACING

#### E6.1 GENERAL

##### E6.1.1 Description

- (a) This Specification shall cover the installation of Crushed Limestone Paths, as well as the installation of Granular Surfacing at the Orientation Node, as described by Drawings. The Work to be done by the Contractor under this Specification shall include the furnishing of all superintendence, overhead, labour, materials, equipment, tools, supplies and all things necessary for and incidental to the satisfactory performance and completion of all Work as hereinafter specified. This Specification shall supplement CW 3110-R7 'Sub-Grade, Sub-Base and Base Course Construction', and 3150-R4 'Gravel Surfacing'.

#### 1.1 PRODUCTS

##### 1.1.1 Materials

- (a) Limestone Dust Topping
  - (i) Limestone dust topping shall be supplied in accordance with the requirements of Specification CW 3150-R4 'Gravel Surfacing', and shall meet the following gradation:

Sieve	Percent Passing
9.5 mm	100
4.75 mm	50 – 100
1.18 mm	20 – 55
0.30 mm	10 – 30
0.075 mm	0 – 12

(b) Granular Base

- (i) Granular Base, to be installed at the Orientation Node, shall be supplied in accordance with the requirements of Specification CW 3110-R7 'Sub-Grade, Sub-Base and Base Course Construction', for 50 mm down crushed limestone.

1.2 EXECUTION

E6.1.2 Sub-grade Preparation

- (a) The sub-grade preparation shall conform to the levels required for the installation of granular base, and in accordance with CW 3110-R7 'Sub-Grade, Sub-Base and Base Course Construction'.
- (b) Minor grading will be required to accommodate the paths and orientation node. All grades are to be approved by Contract Administrator prior to the installation of the base course.

1.2.1 Granular Base

- (a) Granular base shall be installed at the Orientation Node in accordance with Drawing and Specification CW 3110-R7 'Sub-Grade, Sub-Base and Base Course Construction', and to the minimum thickness indicated on the Drawings.
- (b) Each layer shall be compacted to 100% Standard Procter Density. The granular base shall be shaped and rolled alternately to obtain a smooth, even and uniformly compacted base. Water shall be applied as necessary to obtain compaction. If the granular base is excessively moist, it shall be aerated by scarifying with suitable equipment until the moisture content is corrected. Approved mechanical tampers shall be used to compact the granular base in areas not accessible to rolling equipment.
- (c) Base shall be graded to reflect finished grade elevations. The top of the granular base shall be within 10 mm of the required finished base course grade.

1.2.2 Limestone Dust Topping

- (a) Limestone dust shall be installed to compacted thickness as shown on the Drawings. The limestone dust topping shall be compacted to 100% of the Standard Procter Density. Keep topping material moist throughout compaction procedures.

1.2.3 Quality Control

- (a) All Workmanship and all materials furnished and supplied under this Specification are subject to close and systematic inspection and testing by the Contract Administrator including all operations from the selection and production of materials through to final acceptance of the Work. The Contractor shall be wholly responsible for the control of all operations incidental thereto notwithstanding any inspection or approval that may have been previously given. The Contract Administrator reserves the right to reject any materials or Works which are not in accordance with the requirements of the Specification.

1.3 METHOD OF MEASUREMENT

- (a) Granular Surfacing for Paths and Orientation Node shall be measured on a square metre basis as described by Drawings. The amount to be paid for shall be the total number of square metres installed as measured by the Contract Administrator.

1.4 BASIS OF PAYMENT

- (a) Granular Surfacing for Paths and Orientation Node shall be paid for at the Contract Unit Price for the "Items of Work" listed below, which price shall include all costs of labour,

grading, material supply, and all other items incidental to the Work included in this Specification.

Items of Work:

- (i) Crushed Limestone Paths
- (ii) Granular Surfacing at Orientation Node

## **E7. SEATING BLOCKS, STAIRS, ORIENTATION STONES AND CARDINAL POINT MARKERS**

### **E7.1 GENERAL**

#### **E7.1.1 Description**

- (a) This Specification shall cover the supply, and installation of Tyndall Stone Seating Blocks, Tyndall Stone Steps and Granite Orientation Stones, as well as the fabrication of Concrete Cardinal Point Markers as described by the Drawings. The Work to be done by the Contractor under this Specification shall include the furnishing of all superintendence, overhead, labor, materials, equipment, tools, supplies, and all other things necessary for and incidental to the satisfactory performance and completion of all Work as hereinafter specified.

### **E7.2 MATERIALS**

#### **E7.2.1 Products**

- (a) Tyndall Stone Elements
  - (i) All Tyndall Stone used in the construction of Seating Blocks and Steps shall be buff or grey coloured Manitoba Tyndall Limestone as quarried and supplied by Gillis Quarries Ltd. to ASTM C568-79 Category II, High Density Sound Hard Stone, free of clay pockets.
  - (ii) All Tyndall Stone elements shall be as shown on Drawings and approved at quarry by Contract Administrator prior to delivery.
- (b) Orientation Stones
  - (i) Granite Orientation Stones shall be as shown on Drawings and approved at quarry by Contract Administrator prior to delivery.
- (c) Cardinal Point Markers
  - (i) Concrete to meet requirements specified in CAN/CSA A 23.1 "Concrete Materials and Methods of Concrete Construction".
  - (ii) Concrete to be as shown on Drawing.
  - (iii) Aggregate shall be fine granite aggregate with a maximum diameter of 14mm, as described by Drawings.
  - (iv) Reinforcing steel shall be as described by Drawings.
- (d) Granular Base
  - (i) Granular base shall be supplied as per requirements specified in CW 3110-R7 'Sub-Grade, Sub-Base and Base Course Construction'.
- (e) Geotextile
  - (i) Geotextile shall be supplied in accordance with CW 3130-R1 'Supply and Installation of Geotextile Fabrics'.

### **E7.3 EXECUTION**

#### **E7.3.1 Sub-grade Preparation**



- (a) Sub-grade preparation shall conform to CW 3110-R7 'Sub-Grade, Sub-Base and Base Course Construction'.

#### E7.3.2 Granular Base

- (a) Granular Base shall be installed in accordance with the requirements of Specification CW 3110-R7 'Sub-grade, Sub-Base and Base Course Construction' and to a minimum thickness as indicated on the Drawings.

#### E7.3.3 Geotextile

- (a) Geotextile shall be installed in accordance with CW 3130-R1 'Supply and Installation of Geotextile Fabrics'.

#### E7.3.4 Delivery and Installation

- (a) Contractor to identify method of delivery and installation for the Tyndall Stone and Granite pieces for review and approval by Contract Administrator.

#### E7.3.5 Stone Elements

- (a) Tyndall Stone Seating Block and Granite Orientation Stones shall be installed on a prepared granular base as described by Drawings.
- (b) Tyndall Stone Seating Blocks and Steps shall have edges trimmed to the satisfaction of the Contract Administrator.
- (c) All Stone Elements shall be level and plumb and shall sit at the required elevation, as described by Drawings.
- (d) All Stone Elements shall be installed at locations indicated on Drawings and each element shall appear, upon installation, to be aligned properly with adjacent blocks as described by Drawings and approved by the Contract Administrator.

#### E7.3.6 Cardinal Point Markers

- (a) Concrete shall be poured in place to meet size and dimensions described by Drawings.
- (b) Steel reinforcing bars shall be installed as described by Drawings.
- (c) Concrete shall be sandblasted.
- (d) Mock-up of Cardinal Point Identifier shall be submitted to Contract Administrator for approval prior to installation.
- (e) All Cardinal Point Markers shall be level and plumb as described by Drawings.
- (f) All Cardinal Point Markers shall be installed at locations indicated on Drawings and each element shall appear, upon installation, to be aligned properly with adjacent marker as described by Drawings and approved by the Contract Administrator.

#### E7.4 METHOD OF MEASUREMENT

- (a) The supply and installation of Stone elements and Cardinal Point Markers will be measured on a per unit basis. The amount to be paid for shall be the total number of Seating Blocks, Tyndall Stone Steps, Orientation Stones and Cardinal Point Markers supplied and installed in accordance with this Specification, Drawings and as accepted by the Contract Administrator.

#### E7.5 BASIS OF PAYMENT

- (a) The supply and installation of Stone Elements and Cardinal Point Markers will be paid for at the Contract Unit Price for each "Items of Work", listed below, measured as specified herein, which price shall be payment in full for supplying all materials and performing all operations herein described and all other items incidental to the Work included in this Specification.

Items of Work:

- (i) Tyndall Stone Seating Blocks
- (ii) Tyndall Stone Steps
- (iii) Granite Orientation Stones
- (iv) Cardinal Point Markers

**E8. STEEL BOLLARDS**

**E8.1 GENERAL**

- (a) This Specification shall cover the supply and installation of Steel Bollards as described by Drawings. The Work to be done by the Contractor under this Specification shall include the furnishings of all superintendence, overhead, labour, materials, equipment, tools, supplies and all things necessary for and incidental to the satisfactory performance and completion of all Work hereinafter specified.

**E8.2 PRODUCTS**

**E8.2.1 Steel Bollard**

- (a) Bollard shall be constructed and finished as described by Drawings.

**E8.2.2 Concrete Fill**

- (a) All concrete material for fill shall conform to supply and mix requirements specified in CW 2160-R5 'Concrete for Underground Structures and Works'.

**E8.3 EXECUTION**

**E8.3.1 Steel Bollards**

- (a) All Steel Bollards shall be installed at locations indicated on Drawings and each element shall appear, upon installation, to be aligned properly with adjacent bollards as described by Drawings and approved by the Contract Administrator.
- (b) All Steel Bollards shall be plumb and level and shall sit at the required height and depth, as described by Drawings.

**E8.3.2 Concrete Fill**

- (a) Concrete fill shall be installed as specified in CW 2160-R5 'Concrete for Underground Structures and Works' to depth indicated by Drawings.

**E8.4 METHOD OF MEASUREMENT**

- (a) The supply and installation of Steel Bollards will be measured on a unit basis. The number to be paid for shall be the total number of each supplied and installed in accordance with this Specification, and Drawings and accepted by the Contract Administrator.

**E8.5 BASIS OF PAYMENT**

- (a) The supply and installation of Steel Bollards will be paid for at the Contract Unit Price for the "Items of Work" listed below, measured as specified herein, which price shall be payment in full for performing all operations herein described and all other items incidental to the Work included in this Specification.

Items of Work:

- (i) Steel Bollards

## **E9. FENCING**

### **E9.1 GENERAL**

#### **E9.1.1 Description**

- (a) This Specification shall cover the installation of Salvaged Chain Link Safety Fencing, the supply and installation of New Chain Link Fencing Components as well as the supply and installation of Bollard Chain as described by the Drawing. The Work to be done by the Contractor under this Specification shall include the furnishing of all superintendence, overhead, labour, materials, equipment, tools, supplies, and all other things necessary for and incidental to the satisfactory performance and completion of all Work as specified. Work associated with the installation of New and Salvaged Chain Link Safety Fencing shall in accordance with Specification CW 3550-R2 'Chain Link Fencing'.

### **E9.2 PRODUCTS**

#### **E9.2.1 Materials**

- (a) Salvaged Chain Link Safety Fencing
  - (i) Chain Link Safety Fencing shall be salvaged and reinstalled as described by the Drawings.
  - (ii) Material to be salvaged shall be as shown on the Drawings, deemed in good condition and approved by the Contract Administrator. Salvaged material shall include rails, top and bottom rail sleeve coupling, fabric, fittings and accessories, except terminal and line posts.
- (b) New Chain Link Fencing Components
  - New Chain Link Fencing Components shall conform to CW 3550-R2 'Chain Link Fencing', match height and finish of Salvaged Chain Link Fencing and include those components deemed necessary for the installation of Salvaged Chain Link Fencing.
- (c) Bollard Chain
  - (i) Contractor shall ensure that Bollard Chain shall be supplied in adequate length to accommodate span as described by Drawing, and shall be of type and finish to match existing bollard chain.

### **E9.3 EXECUTION**

#### **E9.3.1 Chain Link Fencing**

- (a) The Contractor shall install chain link fence in accordance with CW 3550-R2 'Chain Link Fencing'.
- (b) Contractor shall visit the site and verify all data and dimensions and report any errors, omissions or discrepancies to the Contract Administrator prior to any installation.

#### **E9.3.2 Bollard Chain**

- (a) Bollard Chain shall be installed by method and to elevation of existing bollard chain.

### **E9.4 METHOD OF MEASUREMENT**

#### **E9.4.1 Chain Link Fencing**

- (a) The installation of Chain Link Safety Fencing will be measured on a lineal metre basis. The amount to be paid for shall be the total number of lineal metres of Salvaged Chain Link Fencing installed in accordance with Specification, and as accepted by the

Contract Administrator. The amount to be paid for shall include the supply and installation of any New Chain Link Fencing Elements deemed necessary for the installation of Salvaged Fence.

## E9.5 BASIS OF PAYMENT

### E9.5.1 Chain Link Fencing

- (a) The installation of Chain Link Fencing shall be paid for at the Contract Unit Price per lineal metre for the "Items of Work", measured as specified herein, which price shall be payment in full for supplying all materials and for performing all operations herein described and all other items incidental to the Work included in this Specification. The supply and installation of New Bollard Chain shall be deemed incidental and included in the payment for Chain Link Fencing.

Items of Work:

- (i) Chain Link Fencing

## E10. RECYCLED TIRE PADDING

### E10.1 GENERAL

#### E10.1.1 Description

- (a) This Specification shall cover the supply and installation of Recycled Tire Padding as described by the Drawing. The Work to be done by the Contractor under this Specification shall include the furnishing of all superintendence, overhead, labour, materials, equipment, tools, supplies, and all other things necessary for and incidental to the satisfactory performance and completion of all Work.

### E10.2 PRODUCTS

#### E10.2.1 Materials

- (a) Recycled Tire Padding
  - (i) Shall be deemed in good condition by Contract Administrator prior to installation. Shall be clean and free of toxic or harmful materials.
- (b) Ties
  - (i) Cable ties shall be supplied as described by Drawings.

### E10.3 EXECUTION

- (a) Recycled Tire Padding
  - (i) Tires shall be installed as described by Drawings.

### E10.4 METHOD OF MEASUREMENT

- E10.4.1 The supply and installation of Recycled Tire Padding will be measured on a lineal metre basis. The amount to be paid for shall be the total number of lineal metres of padding installed in accordance with Specification, and as accepted by the Contract Administrator.

### E10.5 BASIS OF PAYMENT

- E10.5.1 The supply and installation of Recycled Tire Padding shall be paid for at the Contract Unit Price per lineal meter for the "Items of Work", measured as specified herein, which price shall be payment in full for supplying all materials and for performing all operations herein described and all other items incidental to the Work included in this Specification.

Items of Work:

(i) Recycled Tire Padding

**E11. TREE PLANTING**

**E11.1 GENERAL**

- (a) This Specification shall cover the supply and installation of new trees. The Work to be done by the Contractor under this Specification shall include the furnishing of all superintendence, overhead, labour, miscellaneous materials, equipment, tools, supplies and all other things necessary for and incidental to the satisfactory performance and completion of all Work as hereinafter specified.
- (b) All planting and replacements must be completed by June 15th of any given year.

**E11.1.1 Source Quality Control**

- (a) All new trees shall be randomly inspected at the source upon request of the Contract Administrator.
- (b) Trees are to be grown in nurseries under proper cultural practices as recommended by the Canadian Nursery Trade Association.
- (c) Only those trees will be accepted which have been grown for at least the four (4) previous years in local Manitoba nurseries located in an Agricultural Canada Plant Hardiness Zone designation of 2(a or b) or 3(a or b), and within a 250 kilometres radius of Winnipeg. Trees that have grown in plant hardiness zones 1 and 4 or greater will be rejected.

**E11.1.2 Maintenance**

- (a) The Contractor shall maintain and warrant planting of new plant material against any and all defects or deficiencies resulting from insect infestation, disease and mechanical damage due to improper handling, installation or maintenance, for the duration of the contract. Nursery stock damaged by vandalism or reasons beyond the control of the Contractor shall be replaced by the City.
- (b) End-of-Contract inspection will be conducted by the Contract Administrator with representation by the City.
- (c) The Contract Administrator reserves the right to request material replacement or extend the Contractor's responsibilities for an additional one (1) year if, at the end of the Warranty Period, leaf development and growth are not sufficient to ensure future survival of the tree.

**E11.1.3 Replacements**

- (a) During the Maintenance Period, the Contractor shall remove from Site any new plant material that has died or failed to grow satisfactorily as determined by the Contract Administrator and replace as per Specifications within a maximum thirty-day period from notification.
- (b) New plants found to be defective shall be replaced within three (3) days of notification to the Contractor.

**E11.2 PRODUCTS**

**E11.2.1 Miscellaneous Materials**

- (a) *Planting Soil* – as specified in CW 3540-R2.
- (b) *Water* – Water is to be potable and free of minerals which may be detrimental to plant growth.
- (c) *Fertilizer* – Fertilizer is to be a slow release formulation of low nitrogen and high phosphorus e.g. 10-50-12. Apply quantities at rates stated by product manufacturer.

- (d) *Rootball Burlap* - Rootball burlap shall be 150g, Hessian burlap, biodegradable.
- (e) *Anti-dessicant* - Anti-dessicant shall be wax-like emulsion to provide film over plant surfaces reducing evaporation but permeable enough to permit transpiration.
- (f) *Wound dressing* - Wound dressing shall be horticultural accepted non-toxic, non-hardening emulsion.

#### E11.2.2 Plant Material

- (a) All nursery stock supplied shall be Canadian Prairie nursery grown, and of species and sizes indicated in the plant list on the Drawings. Its quality shall be in accordance with the "Guide Specification for Nursery Stock of the Canadian Nursery Trades Association".
- (b) Any nursery stock dug from native stands, wood lots, orchards, or neglected nurseries and which have not received proper cultural maintenance as advocated by the Canadian Nursery Trades Association shall be designated as "collected plants". The use of "collected plants" will not be permitted unless specified below. Nomenclature of specified nursery stock shall conform to the International Code of Nomenclature for Cultivated Plants and shall be in accordance with the approved scientific names given in the latest edition of Standardized Plant Names. The names of varieties not named therein are generally in conformity with the names accepted in the nursery trade.
- (c) All trees are to be supplied in accordance with the Work of this Contract and shall be inspected by the Contract Administrator at the nursery site. At the time of inspection, the Contractor shall permanently tag a suitable branch of each tree with a distinct code clearly indicating that the City of Winnipeg will be the intended recipient of that tree. The tag and code must be approved at least two (2) weeks in advance of their use by the Contract Administrator.
- (d) The tag must be kept on the tree at the time of planting, and removed only when authorized in writing by the Contract Administrator. The Contract Administrator will reject each and every tree that has not been delivered with its tag intact at the planting site.
- (e) Each tag will identify the species of the tree and its caliper at the time in which the tag is placed permanently on the tree. All trees tagging operation shall be conducted after Award of Contract. The use of trees requiring treatments as ordered by Agriculture Canada is prohibited.
- (f) Plants larger than specified may be used if approved by the Contract Administrator or his representative. The use of such plants shall not increase the contract price.
- (g) All nursery stock shall be measured when the branches are in their normal position. Height and spread dimensions specified refer to the main body of the plant and not from branch tip to root base or from branch tip to branch tip. Where trees are measured by caliper (cal), reference is made to the diameter of the trunk measured 300mm above ground as the tree stands in the nursery.
- (h) All nursery stock shall be well branched, densely foliated when in leaf, true to type, structurally sound, possess a well developed, undamaged root system and shall be free of disease, insect infestations, rodent damage, sun scald, frost cracks, and other abrasions or scars to the bark. All parts of the nursery stock shall be moist and show live, green cambium when cut. All trees shall have one (1) sturdy, reasonably straight and vertical trunk and a well-balanced crown with fully developed leader. At least one (1) plant of each variety supplied shall bear a tag showing both the botanical and common name of the plant.
- (i) Trees are to have been root pruned regularly, but not later than one growing season prior to arrival on Site. The Contractor may be required to furnish documentation to

The City of Winnipeg on his root-pruning program. Trees in excess of 75 mm caliper are to have been half root pruned during each of two successive growing seasons, the latter at least, one growing season prior to arrival on Site.

**E11.2.3 Tree Quantity and Size**

- (a) Trees are to be planted at the quantities and calipers listed on the Plant List. Any variation from the specified quantity is to be clearly identified on the Schedule of Prices. Any variations to species, size or caliper of specified trees will require a request for approval from the Contract Administrator.
- (b) Any changes in planting locations shall be determined on-site by the Contract Administrator.
- (c) Trees are to conform to the measurements specified in the Plant List, except that trees larger than specified may be used if approved by the Contract Administrator.
- (d) Trees are to be measured when the branches are in their normal position. Height dimensions specified are to refer to the main body of the tree and not from branch tip to root base. Where trees have been measured by caliper or diameter, reference is to be made to the diameter of the trunk measured 300 mm above the ground as the tree stands in the nursery prior to lifting. Caliper of tree shall be appropriately designed on a permanently fixed tag on one of the branches.

<b>PLANT LIST</b>		
<b>QUANTITY</b>	<b>COMMON NAME / BOTANICAL NAME</b>	<b>SIZE AND REMARKS</b>
<b>DECIDUOUS TREES</b>		
11	Basswood / <i>Tilia Americana</i>	70mm caliper, min. 3200mm ht., min. 950mm wide rootball, straight trunk, balanced head, two stakes per tree.

**E11.2.4 Shipment and Pre-Planting Care**

- (a) Shipment of trees and the excavation of holes shall be coordinated to ensure minimum time lapse between digging and planting.
- (b) Branches of trees shall be tied securely, and trees shall be protected against abrasion, exposure and extreme temperature change during transit. Avoid binding of trees with rope or wire which would damage bark, break branches or destroy natural shape of tree. Give full support to root ball of trees during lifting.
- (c) Tree foliage shall be covered with a tarpaulin, and bare roots shall be protected by means of dampened straw, peat moss, saw dust or other acceptable material to prevent loss of moisture during transit and storage.
- (d) Broken and damaged roots shall be removed with sharp pruning shears. Make clean cuts, and cover cuts over 10 mm diameter with a tree wound dressing.
- (e) Roots shall be kept moist and protected from sun and wind. Heel-in trees, which cannot be planted immediately in shaded areas, and water well.

**E11.3 EXECUTION**

E11.3.1 General

- (a) Contractor shall visit the site and verify all data and dimensions and report any errors, omissions or discrepancies to the Contract Administrator prior to any installation.

E11.3.2 Workmanship

- (a) Location of trees shall be staked out or painted on Site by the Contractor. Locations shall be approved by the Contract Administrator prior to installation.
- (b) Anti-desiccant shall be applied in accordance with material manufacturer's instructions with prior approval of the Contract Administrator.
- (c) Coordinate operations. Keep Site clean and planting holes drained. Immediately remove soil or debris spilled onto street pavement, grass or sidewalk.

E11.3.3 Planting Time

- (a) Deciduous trees shall be planted during dormant period before buds have broken. Trees noted for spring planting only, must be planted in dormant period.
- (b) When permission has been obtained from the Contract Administrator to plant deciduous trees after buds have broken, plants shall be sprayed with anti-desiccant to slow down transpiration prior to transplanting.
- (c) Plant only under conditions that are conducive to health and physical conditions of trees.
- (d) Provide planting schedule to Contract Administrator. Extending planting operations over long period using limited crew will not be accepted.
- (e) The Contractor must obtain all above and belowground clearances from all the utilities as well as the appropriate District Operations Branch in a timely manner so as not to jeopardize the schedule of the complete tree-planting Contract.

E11.3.4 Excavation of Tree Pits

- (a) Excavation of planting pits shall be located as indicated by stakes or paint marks.
- (b) The Contractor must not commence excavation of any tree pits until the full extent of all buried utilities and services are located and protected.
- (c) The Contractor shall hand excavate all tree pits located over underground utility lines. Tree wells not located over underground utilities may be machine excavated. Tree wells shall be excavated with vertical sides to the full width of the surface area as shown on the Drawings. All excavated material shall be disposed of off-Site.

E11.3.5 Planting of Nursery Stock

- (a) Each balled specimen shall be handled with great care so that the root balls shall not be broken. Burlap shall be folded back only at the top and sides.
- (b) Broken root balls or balls consisting of loose soil shall not be accepted and shall be replaced. Broken roots of deciduous stock shall be pruned back prior to planting.
- (c) Where the root ball of plant material is enclosed in wire baskets, the wire baskets shall be removed from the root ball once the tree has been located properly in the pit. Removal shall be by a min. of 4 vertical cuts equally spaced around the baskets without damaging the root ball. Cutting of the 2 lowest horizontal strands of the wire basket before placing the tree in the pit is acceptable provided that the bottom of the root ball will remain intact.

E11.3.6 Planting Procedure

- (a) With balled and burlaped root balls and root balls in wire baskets, burlap shall be loosened and cut away from the top 1/3 without disturbing root ball. Burlap or rope



shall not be pulled from under root ball. Non-biodegradable wrapping shall be removed.

- (b) After inserting the tree and tamping the root system with topsoil in layer of 150 mm, water shall be poured in until the pit is thoroughly soaked. Filling of the hole shall then be completed and the fill-in soil shall be packed firmly around the roots, leaving a concave surface for convenient watering. After filling, the planting shall be watered at frequent intervals. No tree pit shall be left open at the end of the Contractor's Work Day.
- (c) Each tree is to have an earth saucer at its base having a diameter as large as the excavation with a 10 cm lip formed at the perimeter of the saucer to retain water.
- (d) Planting shall be done during periods suitable to weather conditions and locally accepted practice. All nursery stock shall be set plumb in the centre of pits and at levels as shown on the planting details after settlement has taken place.
- (e) Nursery stock and salvaged material shall be faced to give the best appearance or relationship to adjacent structure and to the approval of the Contract Administrator of his representative. Trees shall be placed equal to depth they were originally growing in nursery.

#### E11.3.7 Fertilizing

- (a) When planting is completed, surface of planting saucer shall be fertilized, meeting the requirements of Specification. Fertilizer shall be mixed thoroughly with top layer of planting soil and watered in well.

#### E11.3.8 Pruning

- (a) All deciduous trees shall be pruned immediately after planting. The amount of pruning shall be limited to the minimum necessary to remove dead or injured branches and to compensate for the loss of roots as a result of transplanting operations. Pruning shall be done in such a manner as to preserve the natural character of the plants. Leaders shall not be removed. Only clean, sharp tools shall be used. All cuts shall be clean and flush, leaving no stubs. Cuts, bruises or scars on the bark shall be traced back to living tissue and removed. The affected areas shall be shaped so as not to retain water and all cuts of more than 25 mm (1") in diameter shall be painted with approved tree paint.

#### E11.3.9 Watering

- (a) Trees shall be watered during the planting procedure as described previously, and once a week thereafter, or more frequently if required.
- (b) A complete record shall be kept of each series of waterings for all planted trees, noting: 1) location, and 2) date of watering. This record shall be sent bi-weekly to the Contract Administrator – Fax: (204) 927-3443.
- (c) Forty (40) litres of water per 25 mm calliper per application shall be applied using deep root feeder or low/pressure nozzle and hose. The water stream shall not gouge out a hole in the soil and mulch.

#### E11.3.10 Staking

- (a) All trees shall be staked and tied in accordance with the Drawings.

#### E11.4 METHODS OF MEASUREMENT

- (a) Trees planting shall be measured on a per unit basis. The amount to be paid for shall be the total number of trees supplied and installed in accordance with this Specification, Drawings and as accepted by the Contract Administrator.

#### E11.5 BASIS OF PAYMENT

- (a) Tree planting shall be paid for at the Contract Unit Price for the "Items of Work" listed below. New material price shall include all costs of labour and material supply, and all other items incidental to the Work included in this Specification.

Items of Work:

- (i) Tree Planting

## **E12. SITE FURNITURE**

### **E12.1 GENERAL**

- (a) This Specification shall cover the supply and installation of new Waste Receptacles, as well as the installation of salvaged Sign and Bicycles Stand, and relocation of salvaged Waste Receptacle and Picnic table as described by Drawings. The Work to be done by the Contractor under this Specification shall include the furnishings of all superintendence, overhead, labour, materials, equipment, tools, supplies and all things necessary for and incidental to the satisfactory performance and completion of all Work hereinafter specified.

### **E12.2 PRODUCTS**

#### **E12.2.1 New Waste Receptacle**

- (a) Waste receptacle shall be standard City of Winnipeg 'Expanded Metal Basket' Type (SCD 106, see Appendix A), as supplied by the City of Winnipeg, Public Works Department. Waste Receptacles can be purchased through the contact indicated in E12.2.3.

#### **E12.2.2 Salvaged Items**

- (a) Salvaged bicycle stand, sign, waste receptacle, and picnic table shall be relocated on Site as shown on Drawings.

#### **E12.2.3 City of Winnipeg Contact:**

Bill Dowbyhuz  
Supervisor of Central Repair / Manufacturing Facility  
Public Works Department  
215 Tecumeh.  
Winnipeg, Manitoba  
R2E 3S4

tel: (204) 986-5505  
fax: 783-1248

### **E12.3 EXECUTION**

#### **E12.3.1 General**

- (a) Contractor shall visit Site and verify all data and dimensions and report any errors, omissions or discrepancies to the Contract Administrator prior to any installation.

#### **E12.3.2 New Waste Receptacle**

- (a) Waste receptacle shall be installed as per SCD 106, Appendix A.

#### **E12.3.3 Salvaged Items**

- (a) Salvaged sign, waste receptacles, bicycle stand and picnic table shall be relocated as shown on Drawing.  
(b) Salvaged sign shall be installed plumb and level.

- (c) Salvaged bicycle stand shall be anchored as described by Drawings.

#### E12.4 METHOD OF MEASUREMENT

##### E12.4.1 New Waste Receptacles

- (a) The supply and installation of New Waste Receptacles will be measured on a per unit basis. The number to be paid for shall be the total number of each supplied and installed in accordance with this Specification and Drawings and accepted by the Contract Administrator.

##### E12.4.2 Salvaged Items

- (a) No measurement will be made for the installation of salvaged Sign, and Bicycle Stand, and the relocation of Picnic Table, and Waste Receptacles.

#### E12.5 BASIS FOR PAYMENT

- (a) The supply and installation of New Waste Receptacle and installation of Salvaged items will be paid for at the Contract Price for each "Items of Work", listed below, which price shall be payment in full for supplying all materials and performing all operations herein described and all other items incidental to the Work included in this Specification.

Items of Work:

- (i) New Waste Receptacle
- (ii) Salvaged Items

# APPENDIX A

TITLE

# EXPANDED METAL BASKET

SCD-106

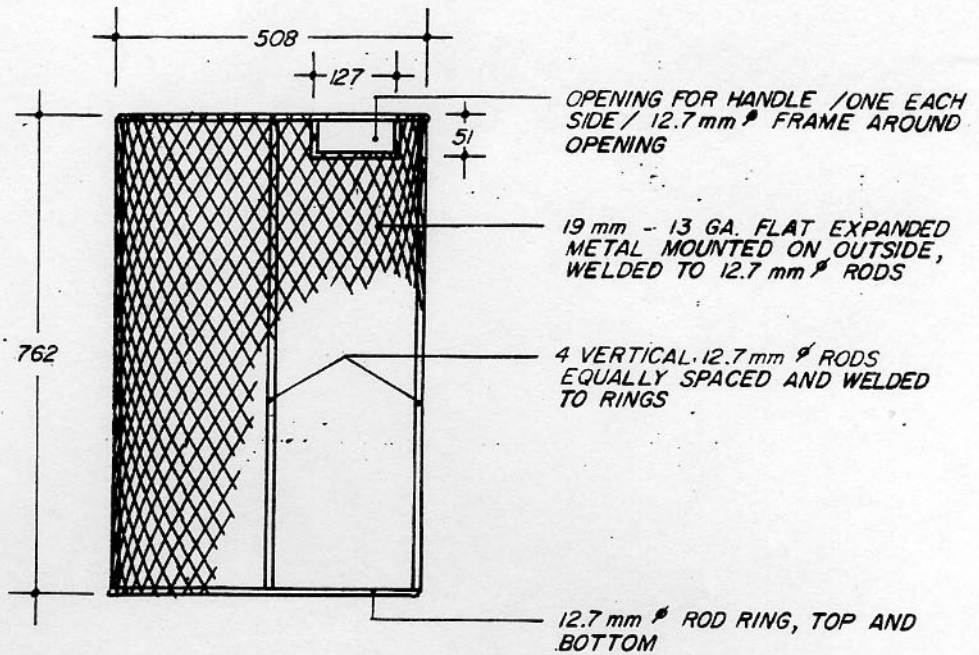

SIDE VIEW

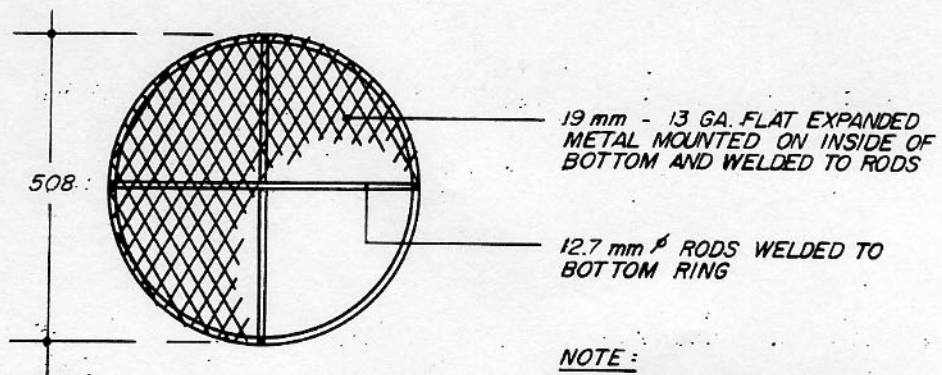

BOTTOM VIEW

**NOTE:**

APPLY ONE COAT OF METAL PRIMER AND ONE COAT ALUMINUM PAINT.

THE CITY OF WINNIPEG  
Parks & Recreation Department  
Planning, Development & Central Services Division  
2799 Roblin Blvd., Winnipeg, Manitoba R3R 0B8

