

NOTES:

USING A TAPE MEASURE FROM EDGE 'A' OF LIP TO END OF CRACK 1 3/4" MAXIMUM

TYPE A

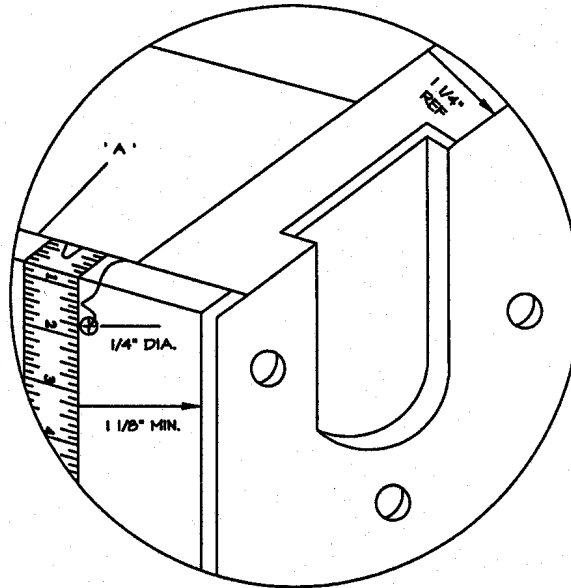

TYPE B

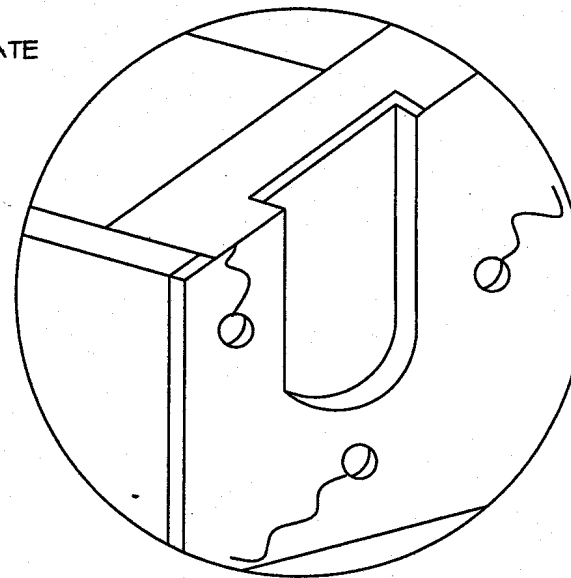

WRAPPER SHEET

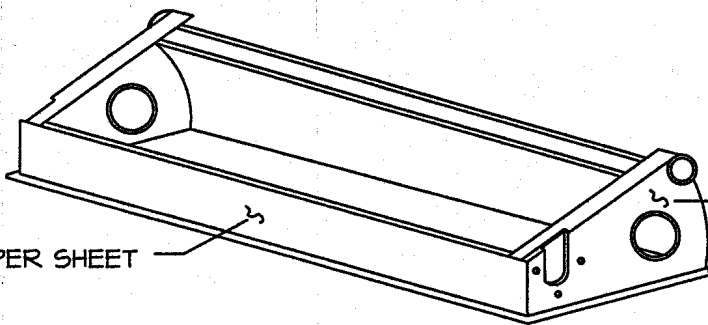

END PLATE

NO.	REVISION	BY	DATE
-----	----------	----	------

SEALS

DRAWN BY: R. Peters	CHECKED BY:	APPROVED
DATE: SEPT. 29/99	USER APPROVAL	



THE CITY OF WINNIPEG  
PUBLIC WORKS DEPARTMENT  
BUILDING SERVICES DIVISION  
100 MAIN STREET, MAIN FLOOR  
WPG, MB. R3C 1A4  
Phone # 986 - 7266

PROJECT

MONTGOMERY ESCALATOR STEP  
BOX DETAIL

SHEET TITLE

PLAN, DETAILS

SCALE

N.T.S.

SHEET NO.

A-1