

ITEM No.	No. REQ'D	DESCRIPTION	MATERIAL	DWG No.
1	1	OCT. SECT. ARM 4 7/8" A/F TO 2 7/8" A/F EXTERIOR DIM.	7 GA. A570 GR.50	
2	1	TENON 2" IPS (2 3/8" OD) x 14" LONG	A53 GR.B SCHED.40	

FINISH:

HOT DIP GALVANIZE TO CSA STANDARD G164-M92 TO NET MINIMUM RETENTION OF 600 g/m²
 ALL AREAS OF DAMAGED GALVANIZING SHALL BE REPAIRED WITH SELF FLUXING LOW TEMPERATURE ZINC BASED ALLOY ROD. USE OF SPRAY ON COATINGS IS NOT ACCEPTABLE.

NOTES:

1. WELDING

ALL WELDING SHALL CONFORM TO CSA STANDARD W59. FABRICATOR SHALL BE FULLY APPROVED BY THE CANADIAN WELDING BUREAU AS PER CSA STANDARD W47.1. LONGITUDINAL SEAM WELD SHALL HAVE 60% MINIMUM PENETRATION EXCEPT 4 1/2" FROM LOWER END OF DAVIT SHALL BE COMPLETE PENETRATION. THE START AND END OF COMPLETE PENETRATION LONGITUDINAL SEAM WELD SECTION SHALL BE SMOOTH AND FREE OF NOTCHES OR OTHER WELD DEFECTS. THE LONGITUDINAL SEAM WELD IN ARMS SHALL BE ADJACENT TO THE FLAT WHICH IS OUTERMOST FLAT THROUGH THE BEND.

2. TOLERANCES

ALL ACROSS FLATS (A/F) ARE EXTERIOR DIMENSIONS. THE BOTTOM OF DAVIT ARMS SHALL BE 4 7/8" +0, -1/8" A/F AND TOP OF DAVIT ARMS SHALL BE 2 7/8", +0 -1/8".

3. IDENTIFICATION

WELD IDENTIFICATION CODE XX-YR, ON DAVIT ARM AT 12" TO 18" FROM BOTTOM END OF DAVIT.
 XX IS THE POLE MANUFACTURERS CODE AND YR IS THE LAST TWO DIGITS OF YEAR OF MANUFACTURE.

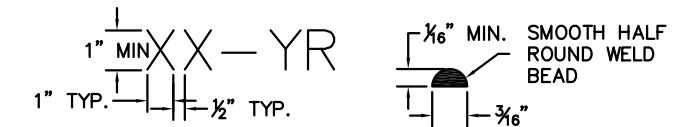

3. LOADING AND DESIGN CRITERIA SHOWN ON SHEET 2 OF DRAWING ST-161.

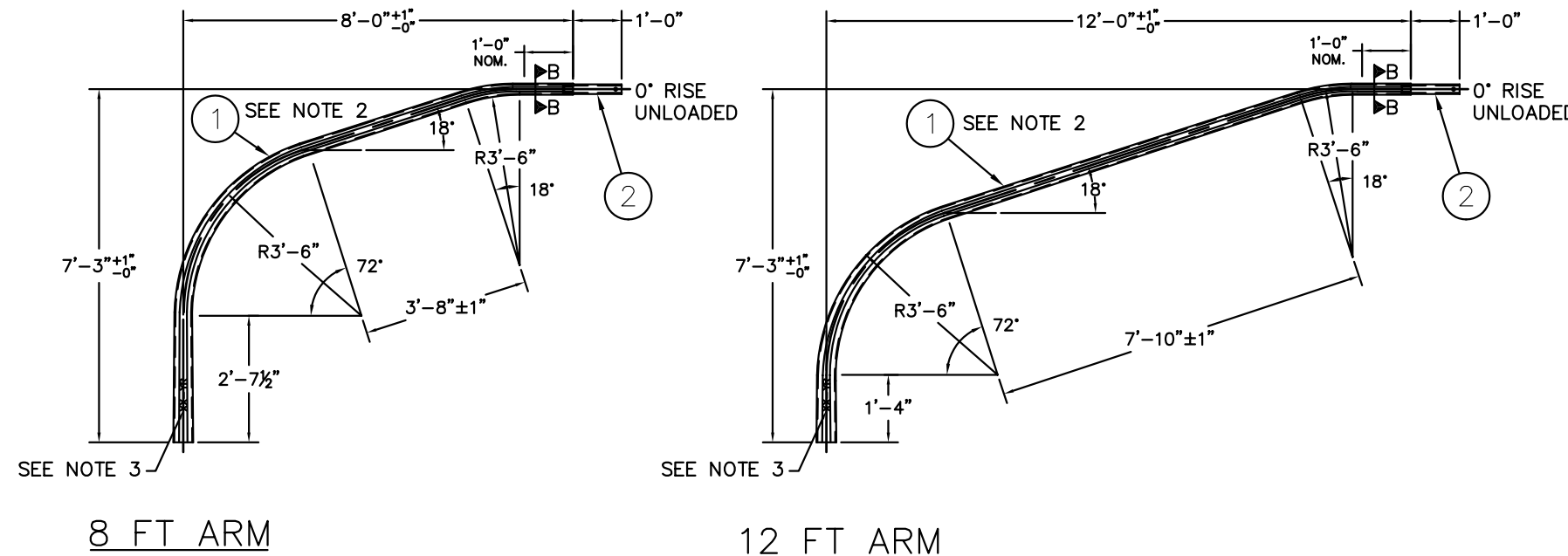

8 FT ARM

12 FT ARM

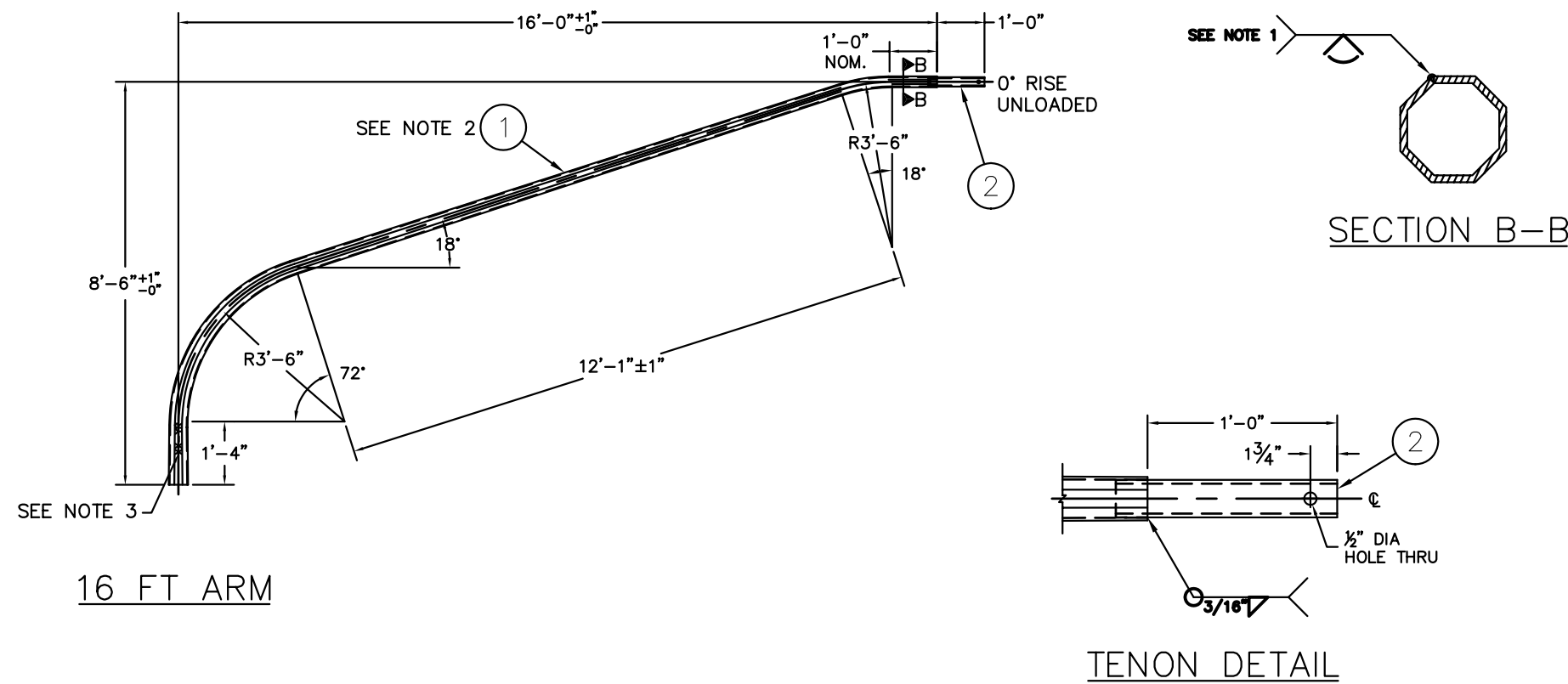

16 FT ARM

SECTION B-B

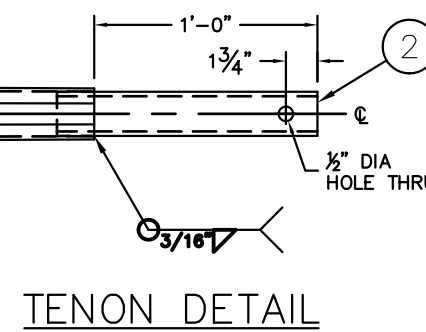

TENON DETAIL

REV. No.	DATE	REVISIONS	APPROVED
THE CITY OF WINNIPEG PUBLIC WORKS DEPARTMENT TRANSPORTATION DIVISION			
GES ENGINEERING INC. CALGARY, AB. PHONE (403) 240-2921 FAX (403) 240-3713			
TRAFFIC SIGNAL LIGHT DUTY DAVIT ARMS OF 8 FT, 12 FT. AND 16 FT. REACH			
DESIGNED AND APPROVED		DRAWN G.G.	DWG No. ST-169
DATE	JUNE 14, 2004	SCALE NTS	SHEET 1 OF 1 REV. No. 0