

TITLE

TACHE BACKLESS BENCH

SCD-121

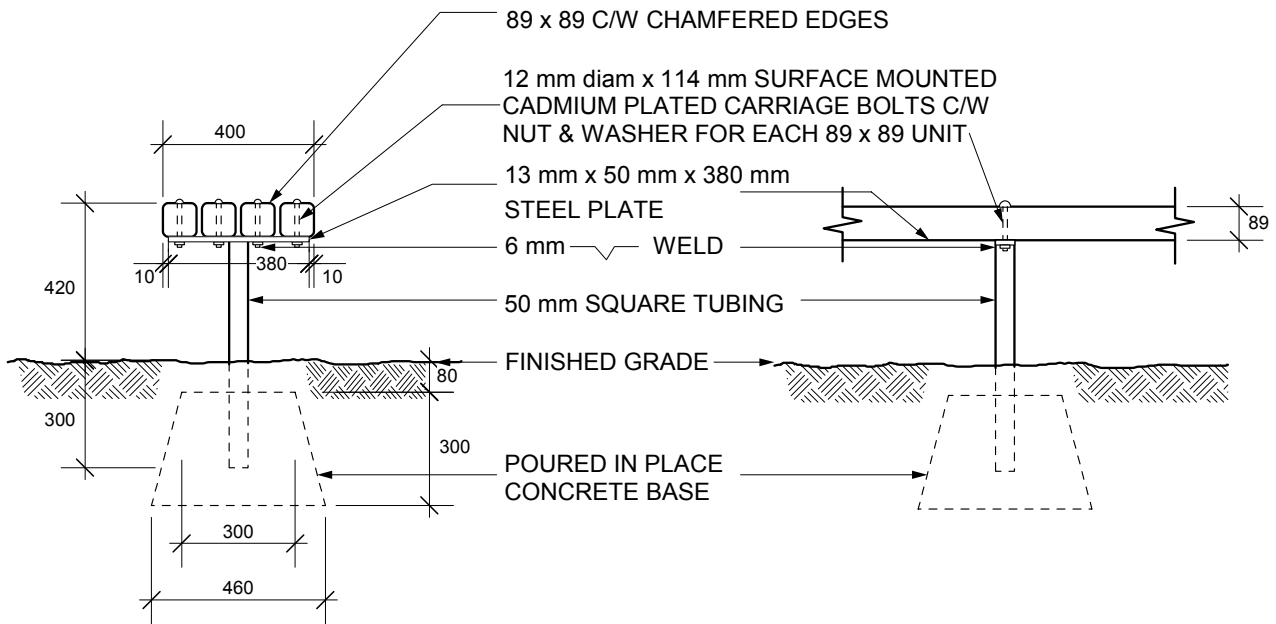
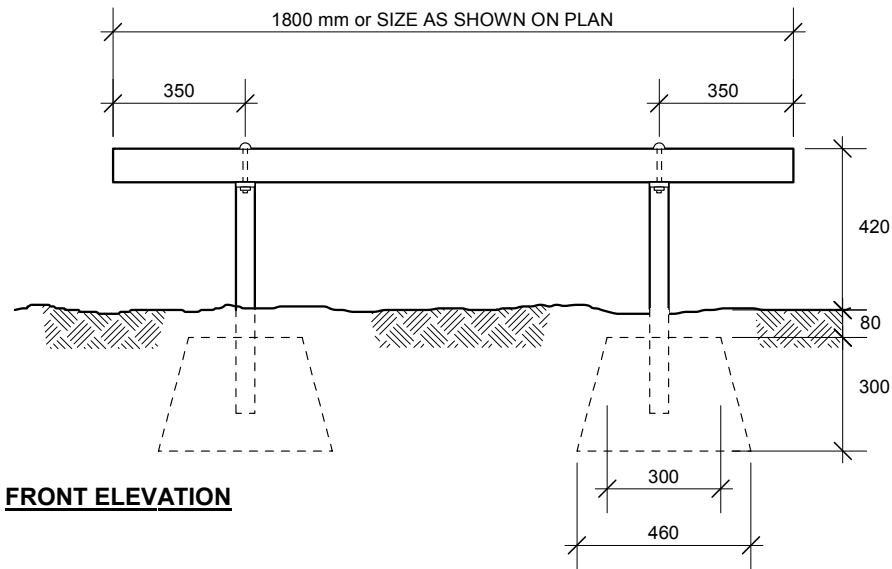

MATERIALS:

WOOD - VERTICAL GRAIN CLEAR SITKA SPRUCE OR B.C. RED CEDAR.

FINISH - SIKKENS CETOL 1 no. 078 NATURAL

METAL - PRIME WITH RUSTOLEUM No. 769. FINISH WITH SAPOLIN BLACK WROUGHT FINISH.

NOTE:

ALL DIMENSIONS SHOWN ARE IN MILLIMETERS.

DRAWN ST
DATE JUNE/03
NOT TO SCALE

THE CITY OF WINNIPEG
Planning, Property and Development Department
Planning and Land Use Division
Unit 15 - 10 Fort Street, Winnipeg, MB, R3C 4X5

