

INSTRUMENT LOOP DIAGRAM

LOOP NO. W703

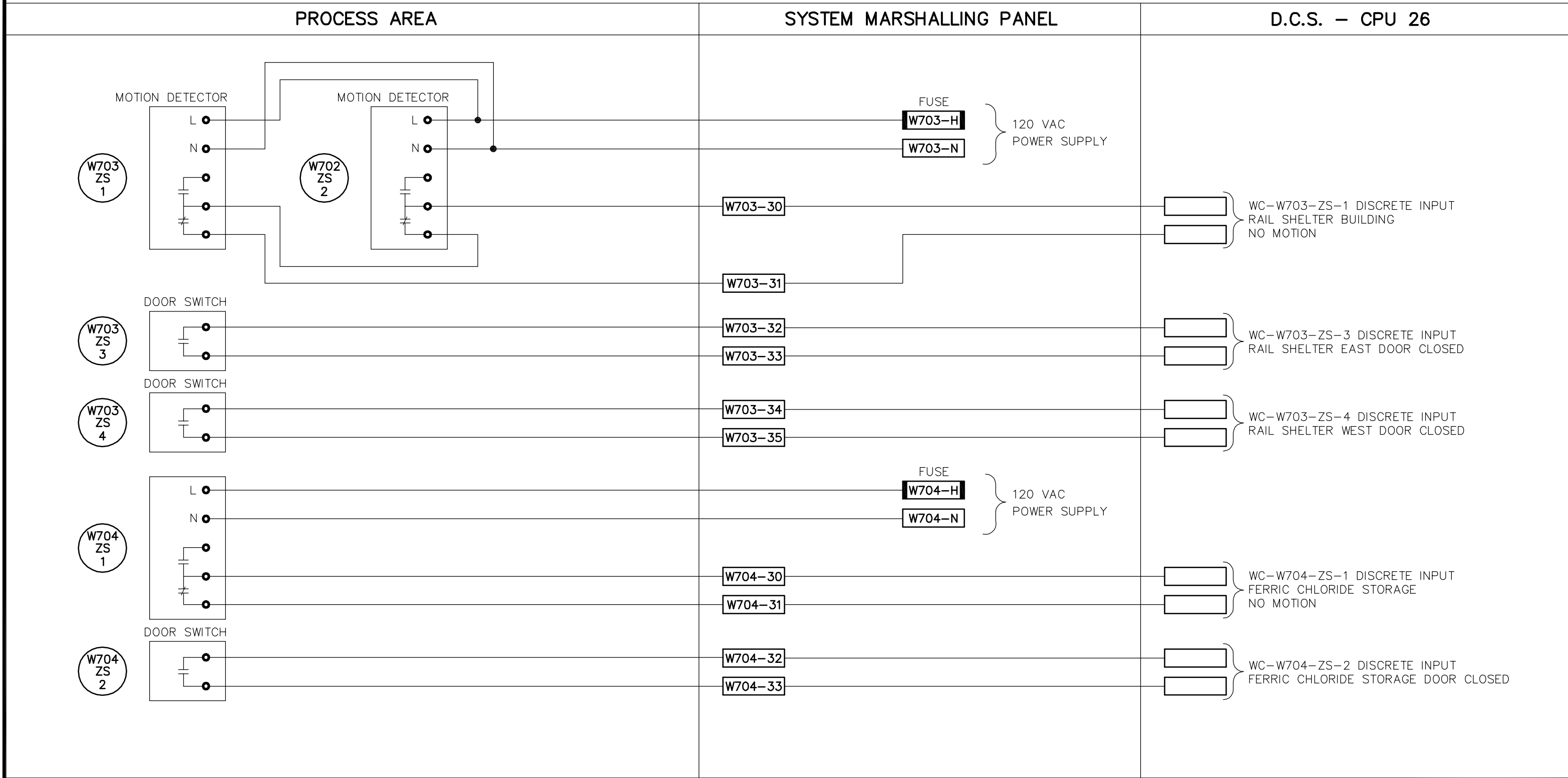

NOTE:

1) CONNECT TO "NORMALLY CLOSED" CONTACTS FOR ALARMS AND "NORMALLY OPEN" CONTACTS FOR EQUIPMENT STATUS, ETC.



Earth Tech (Canada) Inc. Winnipeg, Manitoba 204.477.6381



THE CITY OF WINNIPEG
WATER AND WASTE DEPARTMENT
 NEWPCC – CENTRATE NUTRIENT TREATMENT
 PHOSPHORUS REMOVAL FACILITY

SCALE AS NOTED
 DATE 05 10 27
 DES _____ DWN _____
 CKD _____ APP _____

INSTRUMENT LOOP DIAGRAM
 INTRUSION ALARMS

DRAWING NO.
 ILD-10

DATE	REVISION	APP.