

NOTE:
VERIFY DOOR AND JAMB ON ARCHITECTURAL
PLANS AND SHOP DRAWINGS.

1 DETAIL DOOR-UP DOOR
NTS

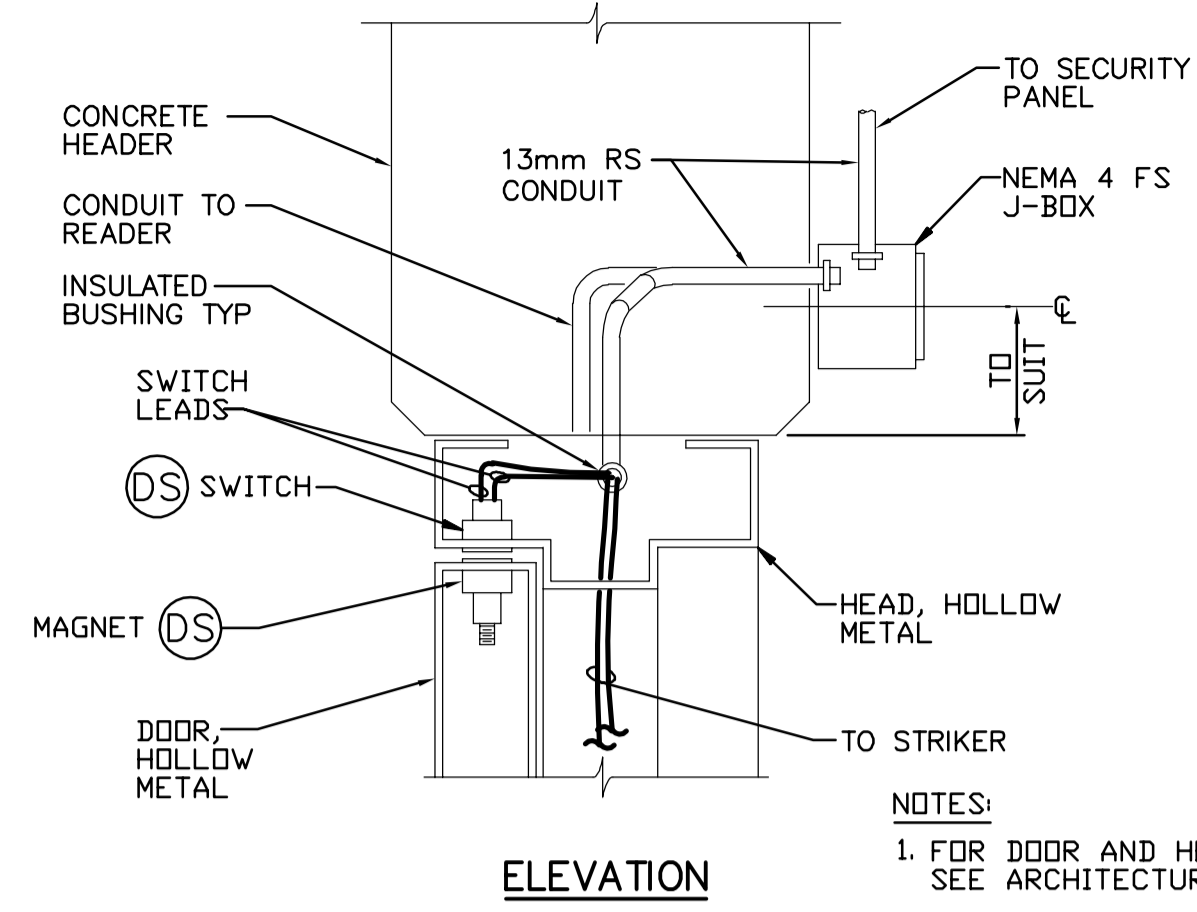

NOTES:
1. FOR DOOR AND HEAD SIZE REQUIREMENTS,
SEE ARCHITECTURAL DETAILS.
2. SPDT CONTACTS INSTALL SWITCH AND MAGNET
IN STRICT ACCORDANCE TO MANUFACTURERS
INSTRUCTIONS.
TYPICAL COMPONENTS: SIMPLEX TIME RECORDER
COMPANY 2760 SERIES MAGNETIC CONTACT SWITCHES.

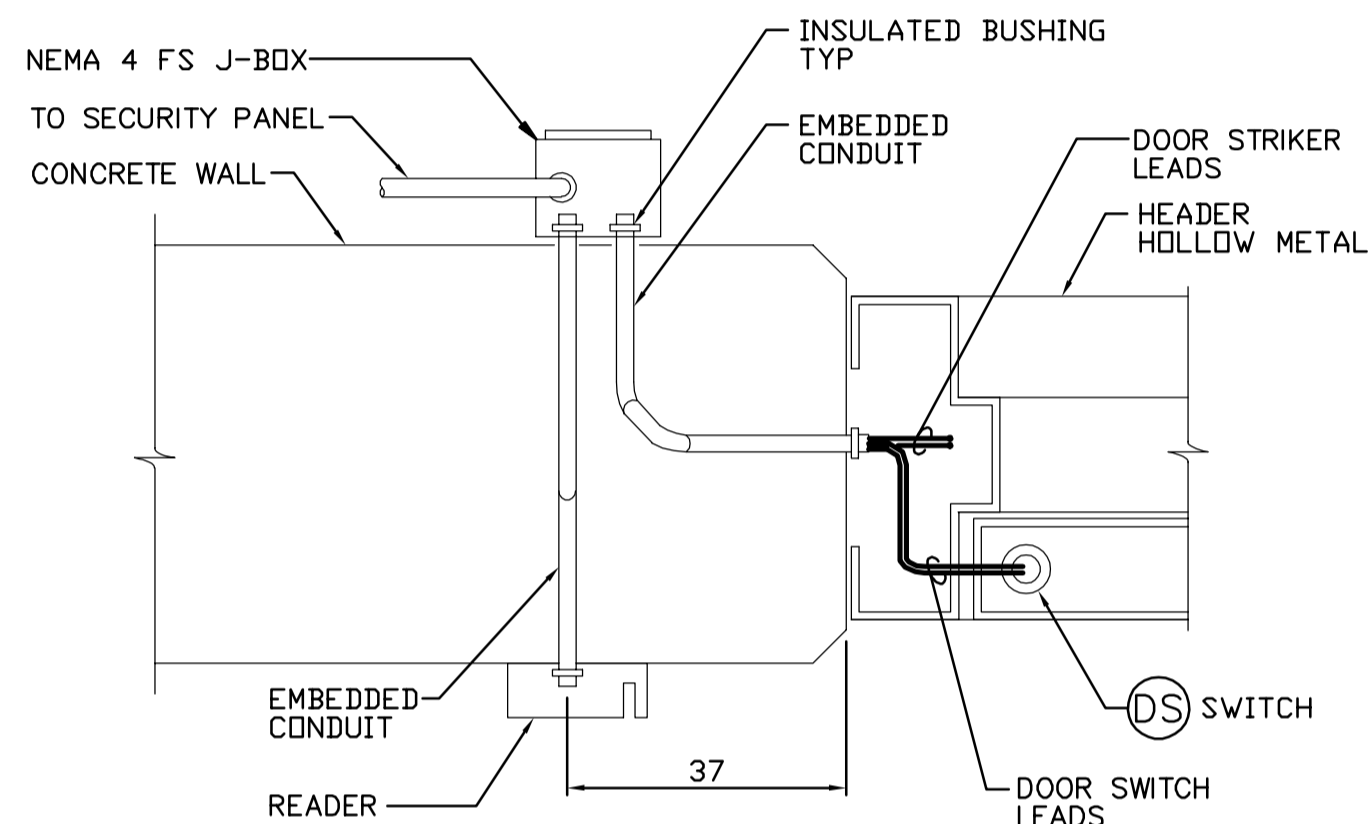

NOTES:
1. FOR DOOR AND HEAD SIZE REQUIREMENTS,
SEE ARCHITECTURAL DETAILS.
2. SPDT CONTACTS INSTALL SWITCH AND MAGNET
IN STRICT ACCORDANCE TO MANUFACTURERS
INSTRUCTIONS.
TYPICAL COMPONENTS: SIMPLEX TIME RECORDER
COMPANY 2760 SERIES MAGNETIC CONTACT SWITCHES.

2 DETAIL DOOR JAMB
NTS



B.M. ELEV.			
DESIGNED BY	LL	CHECKED BY	ND
DRAWN BY	TL	APPROVED BY	AHL
SCALE:	NTS	RELEASED FOR CONSTRUCTION BY:	R. SOROKOWSKI
00 ISSUED FOR TENDER	06/03/29	DATE	2006/03/13
NO. REVISIONS	DATE	BY	DATE



ENGINEER'S SEAL
ORIGINAL SIGNED BY
L.D. LLEWELLYN
2006/03/29
CONSULTANT DRAWING NO.
WB-E0458

THE CITY OF WINNIPEG
WATER AND WASTE DEPARTMENT
ENGINEERING DIVISION

WATER TREATMENT PLANT
MAIN BUILDING
MECHANICAL AND ELECTRICAL

ELECTRICAL
STANDARD DETAILS

CITY FILE NUMBER	
SHEET OF	
CITY DRAWING NUMBER	1-0601B-A-E0458-001-000