

DRAWING NOTES

- 1 CONCRETE WAS BOX. REFER TO STRUCTURAL DRAWINGS FOR DETAILS. PROVIDE CUT-OUT AS SHOWN TO FASTEN WAS BOX FRAME AND FLOAT.
- 2 THE BOX IS TO BE 200MM HIGH X 1000MM WIDE AND RANGE FROM 600MM TO 800MM DEEP. A NEOPRENE GASKET 1000X1100X3MM WILL EXTEND FROM THE EDGE OF THE M.S.S WALL OPENING TO THE END OF THE WAS COLLECTION BOX (1100MM) AND IS DESIGNED TO EXTEND 10MM BEYOND EITHER SIDE OF THE ALUMINUM CLAMPING PLATES. PROVIDE A PLUGGED DRAIN ON THE UNDERSIDE OF THE BOX WHICH CAN ALSO BE USED AS A FILL PORT WHEN THE BOX IS IN THE VERTICAL POSITION. PROVIDE A LATCH ON THE BOX SO THAT THE BOX CAN BE LATCHED IN THE UPRIGHT POSITION TO SEAL THE OPENING.
- 3 MODIFY THE ALUMINUM SIDE PLATES AS SHOWN IN WAS "BOX FRAME" DETAIL. PROVIDE A NEOPRENE GASKET BEHIND THE SIDE PLATES TO ISOLATE THE ALUMINUM SIDE PLATES FROM THE GROUT AND CONCRETE. GROUT THE AREA BEHIND THE NEOPRENE TO ENSURE THAT THE SURFACE WILL BE SMOOTH AND THAT THE DISTANCE BETWEEN THE TWO SIDE PLATES WILL BE 1000MM.

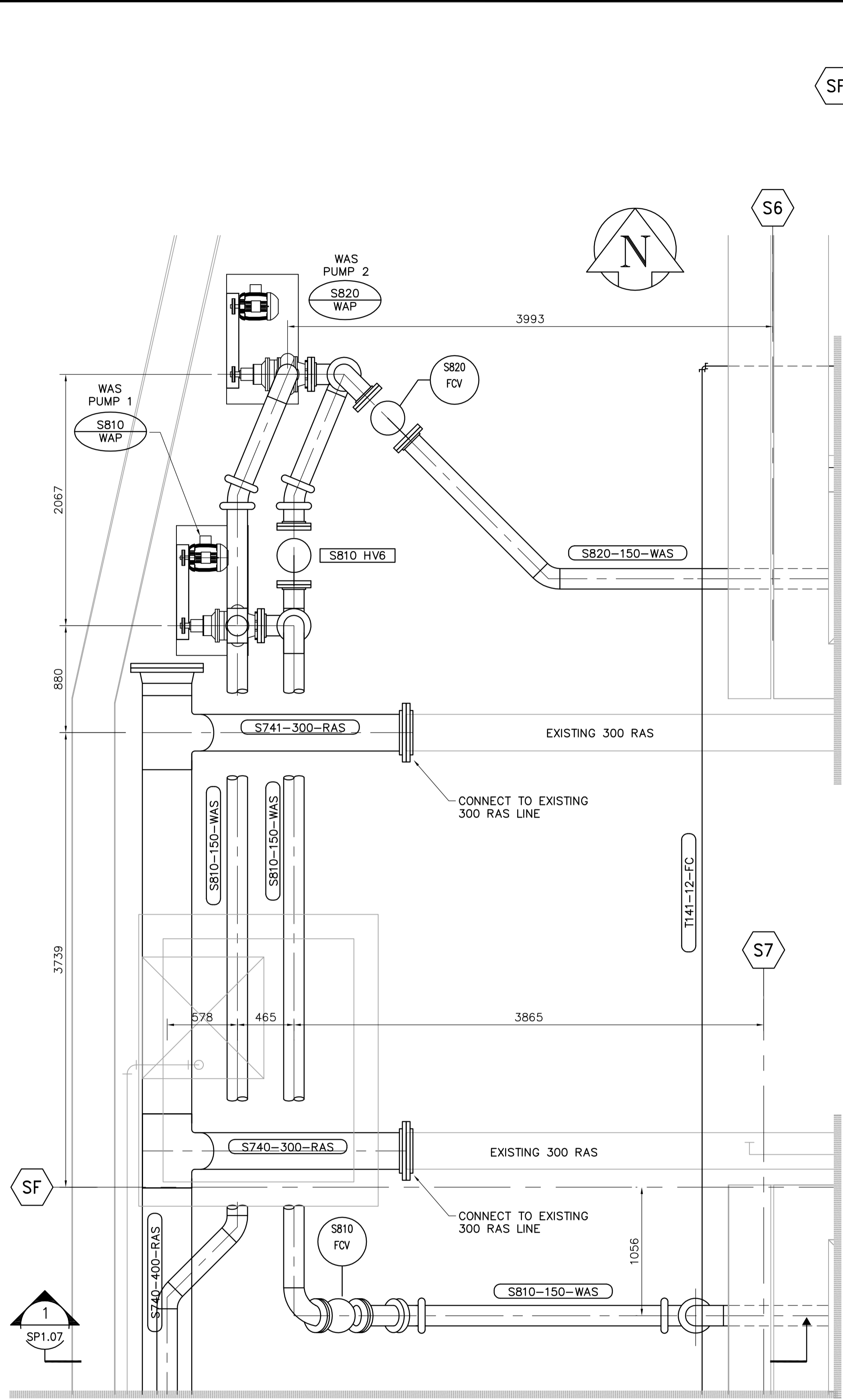

FOR CONTINUATION
SEE DRAWING SP1.03

FOR CONTINUATION
SEE DRAWING SP1.02

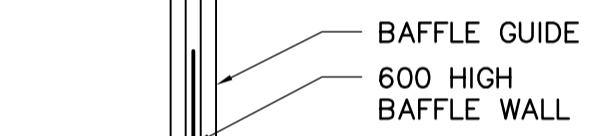
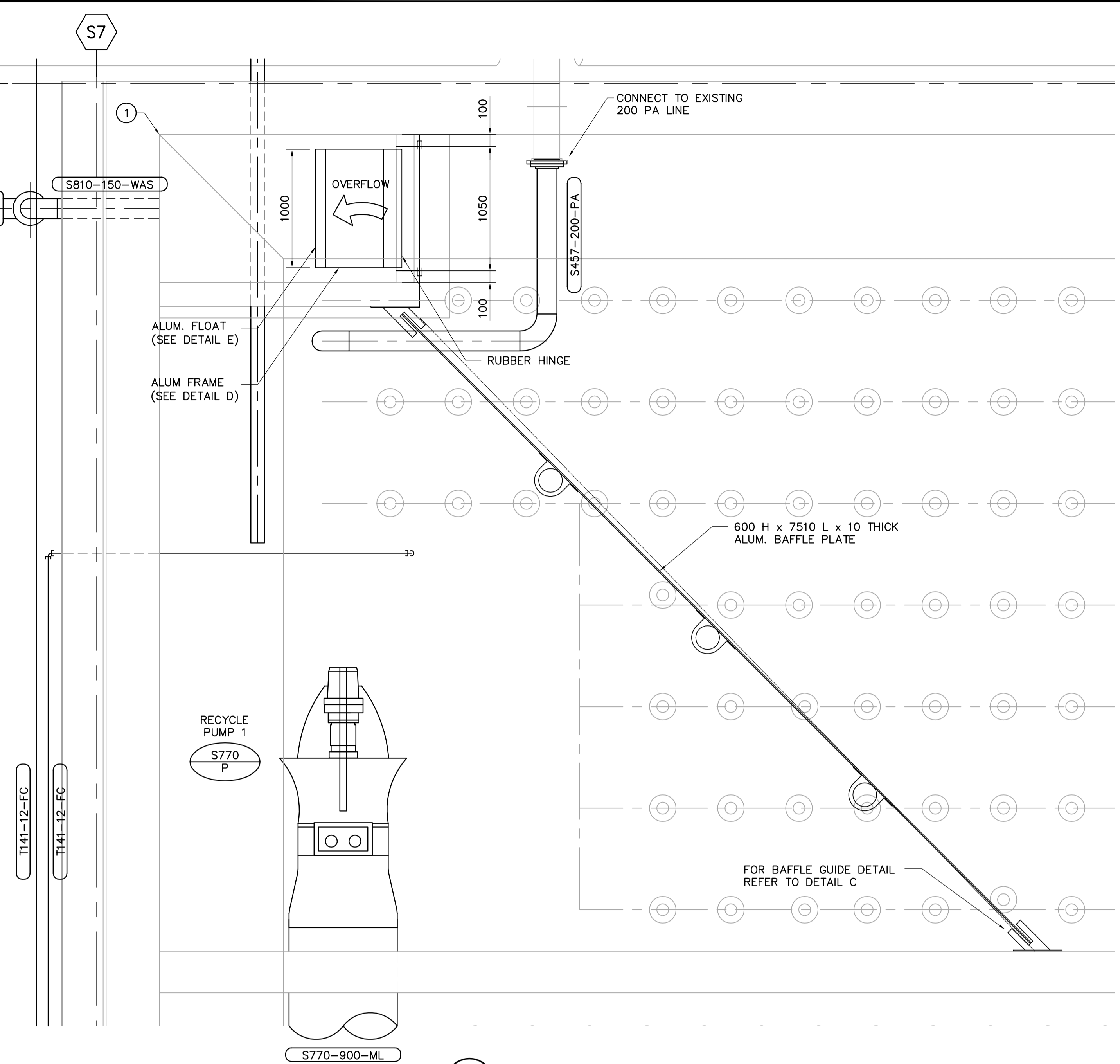

C BAFFLE GUIDE DETAIL
1:25

B WAS BOX AND BAFFLE DETAIL
SP1.01 1:25

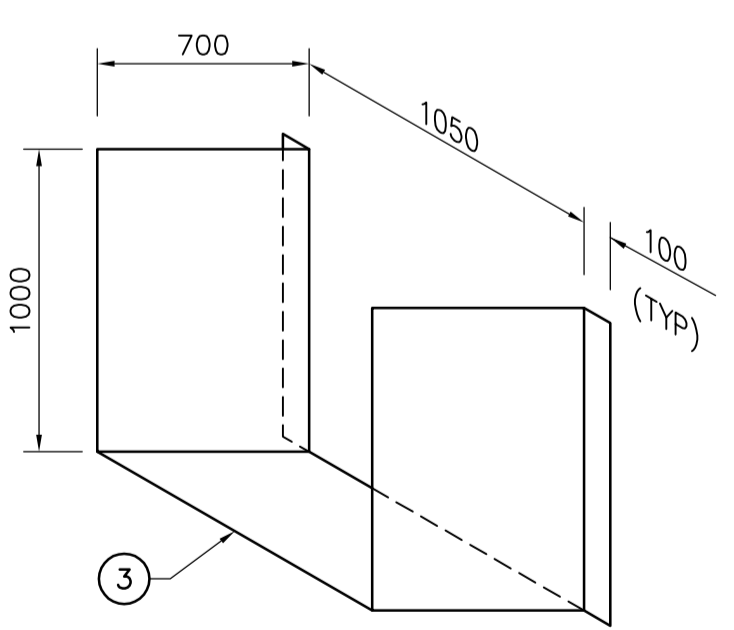

D WAS BOX FRAME DETAIL
1:25

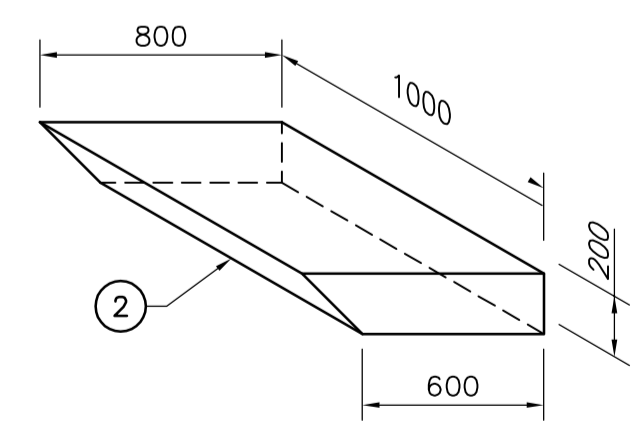

E WAS BOX FLOAT DETAIL
1:25

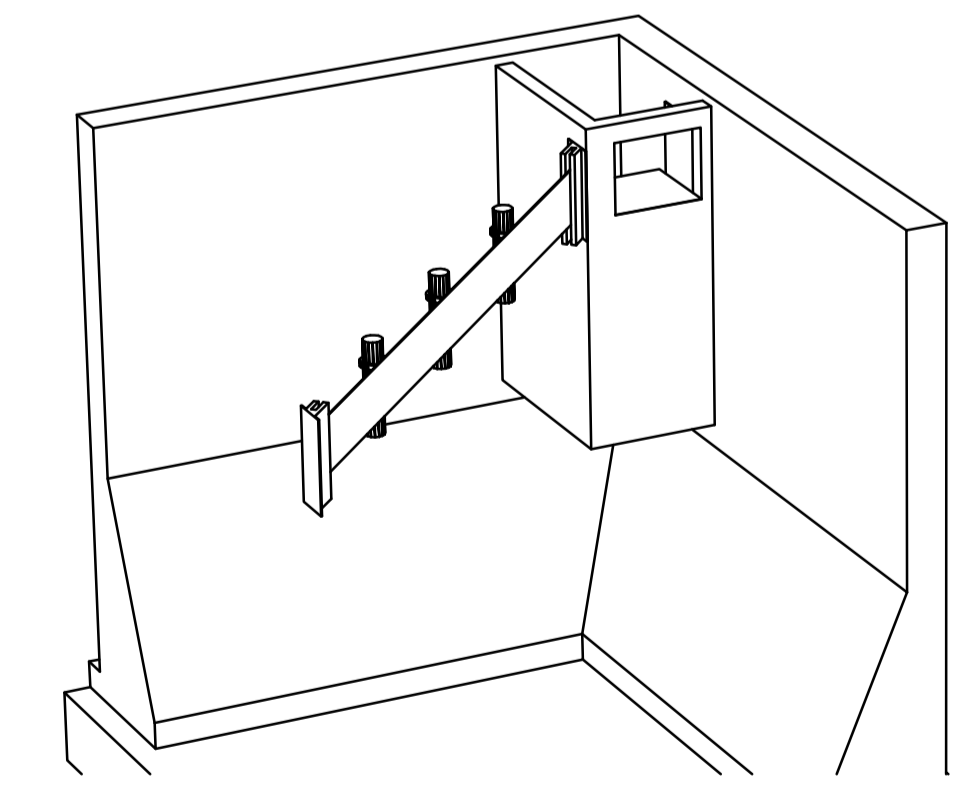

F WAS AREA ISOMETRIC
1:25

A DETAIL PLAN - WAS PUMPING
SP1.01 1:25

GENERAL NOTES

1. CONTRACTOR TO CONFIRM PIPE DIMENSIONS AND EQUIPMENT LOCATIONS PRIOR TO CONSTRUCTION.



<p>EarthTech A Tyco International Ltd. Company</p>		<p>ENGINEER'S SEAL</p> <p>ORIGINAL SIGNED BY P.R. BARSALOU</p> <p>DATE 2006/04/26</p>		<p>THE CITY OF WINNIPEG WATER AND WASTE DEPARTMENT ENGINEERING DIVISION</p>	
DESIGNED BY CL	CHECKED BY KM	CITY FILE NUMBER		CITY DRAWING NUMBER	
DRAWN BY PJY	APPROVED BY JEH	SHEET OF		CONTRACT 3	
HOR. SCALE: 1:50		CONSULTANT DRAWING NO. SP1.04		PROCESS AREA S- BIOREACTORS WAS PUMPING - PLAN AND SECTIONS	
VERTICAL SCALE:		DATE 2005/10/06		DATE 2006/04/26	
NO. REVISIONS		DATE		DATE	
00	ISSUED FOR TENDER	06/04/26	JBC		