

FILE NAME: 6079-S06.1DWG DATE: 2006.07.17 DESCRIPTION: MAIN FLOOR SECTIONS PROJECT No: 2004-058 ADDRESS: 1446 REGENT AVENUE W

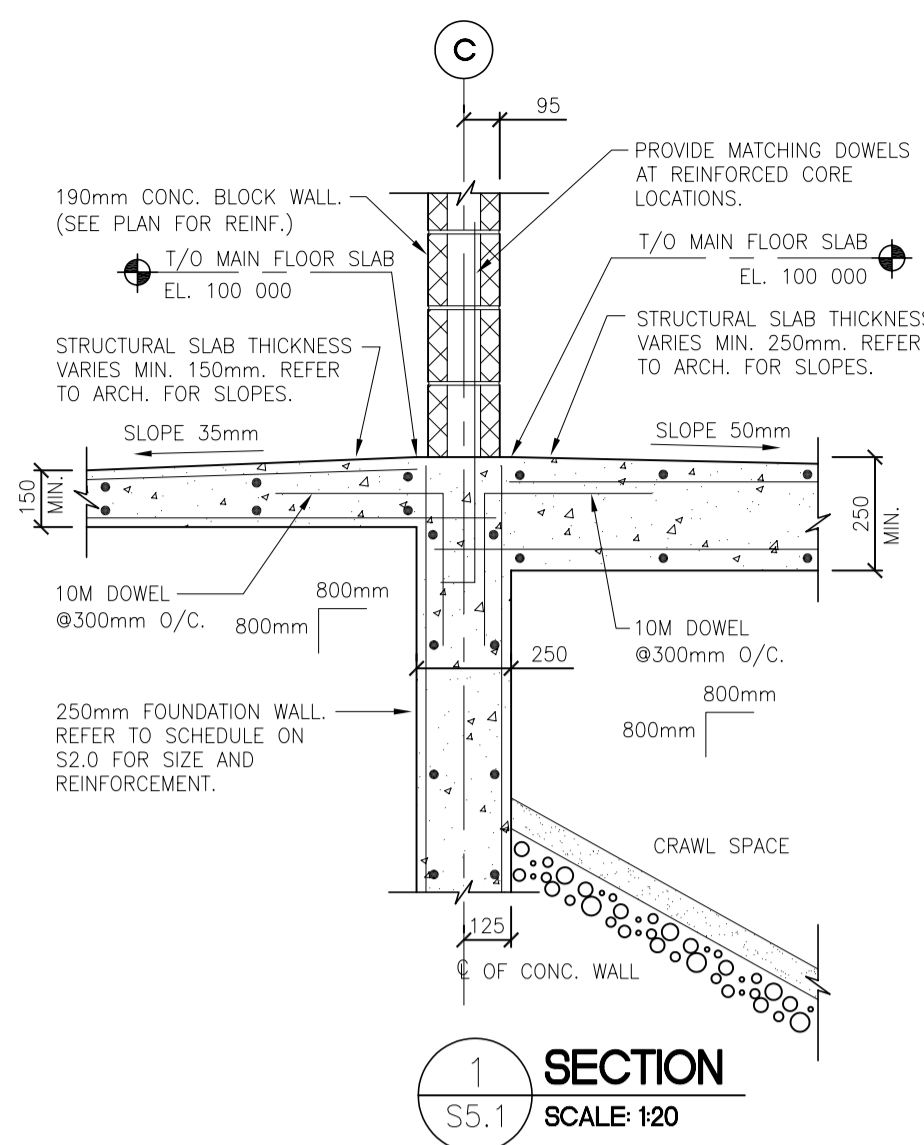

SECTION 1 SCALE: 120

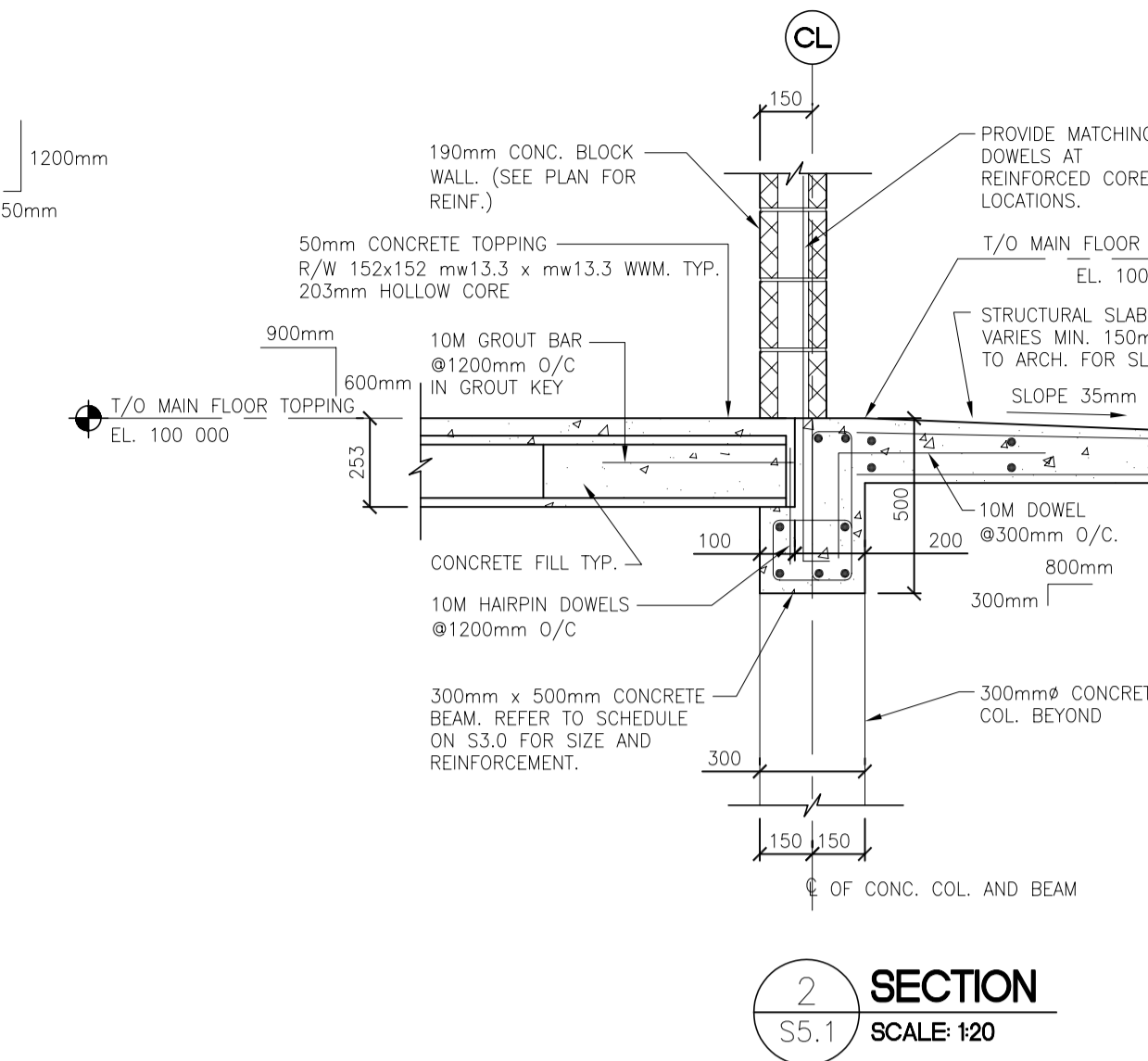

SECTION 2 SCALE: 120

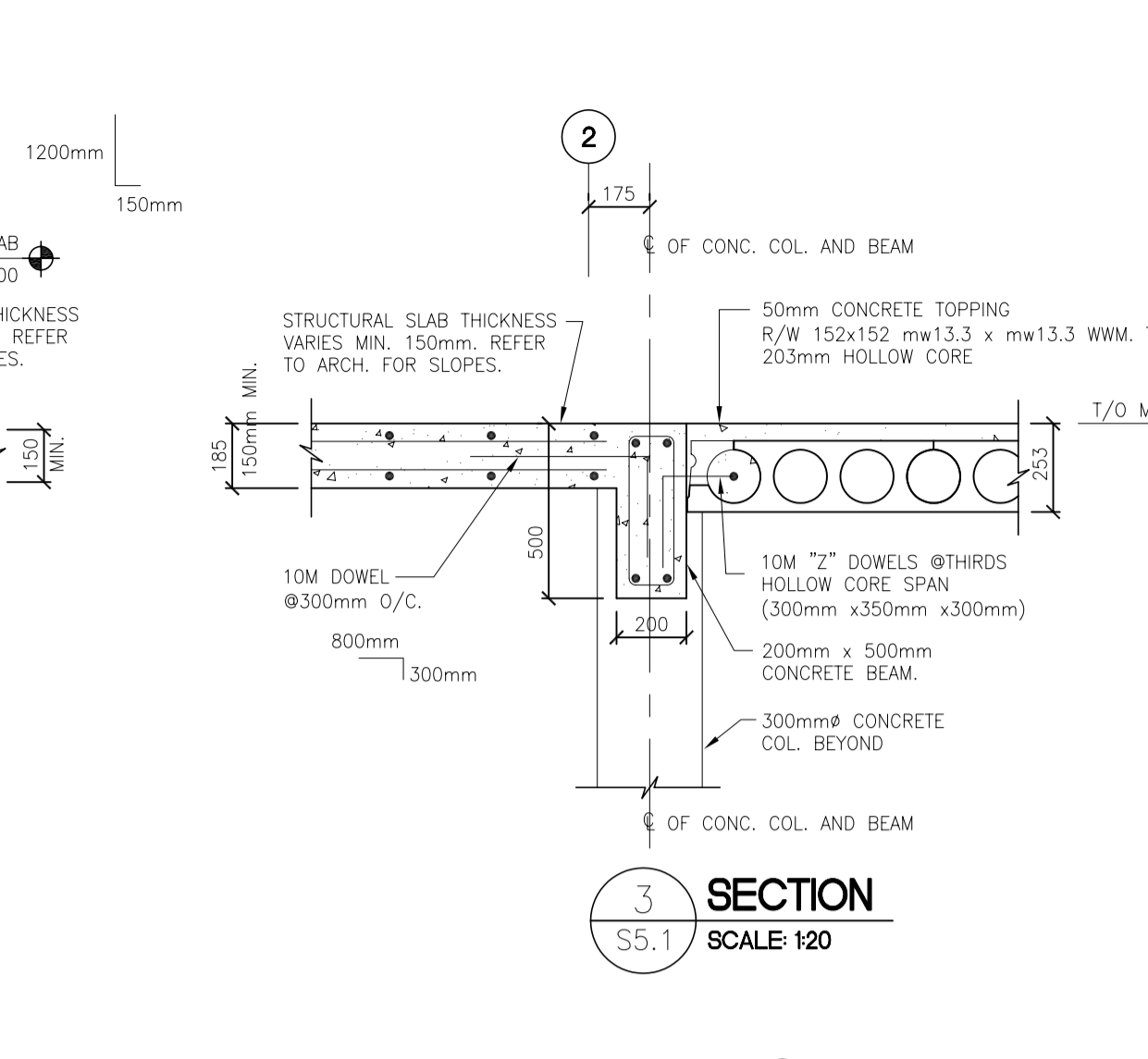

SECTION 3 SCALE: 120

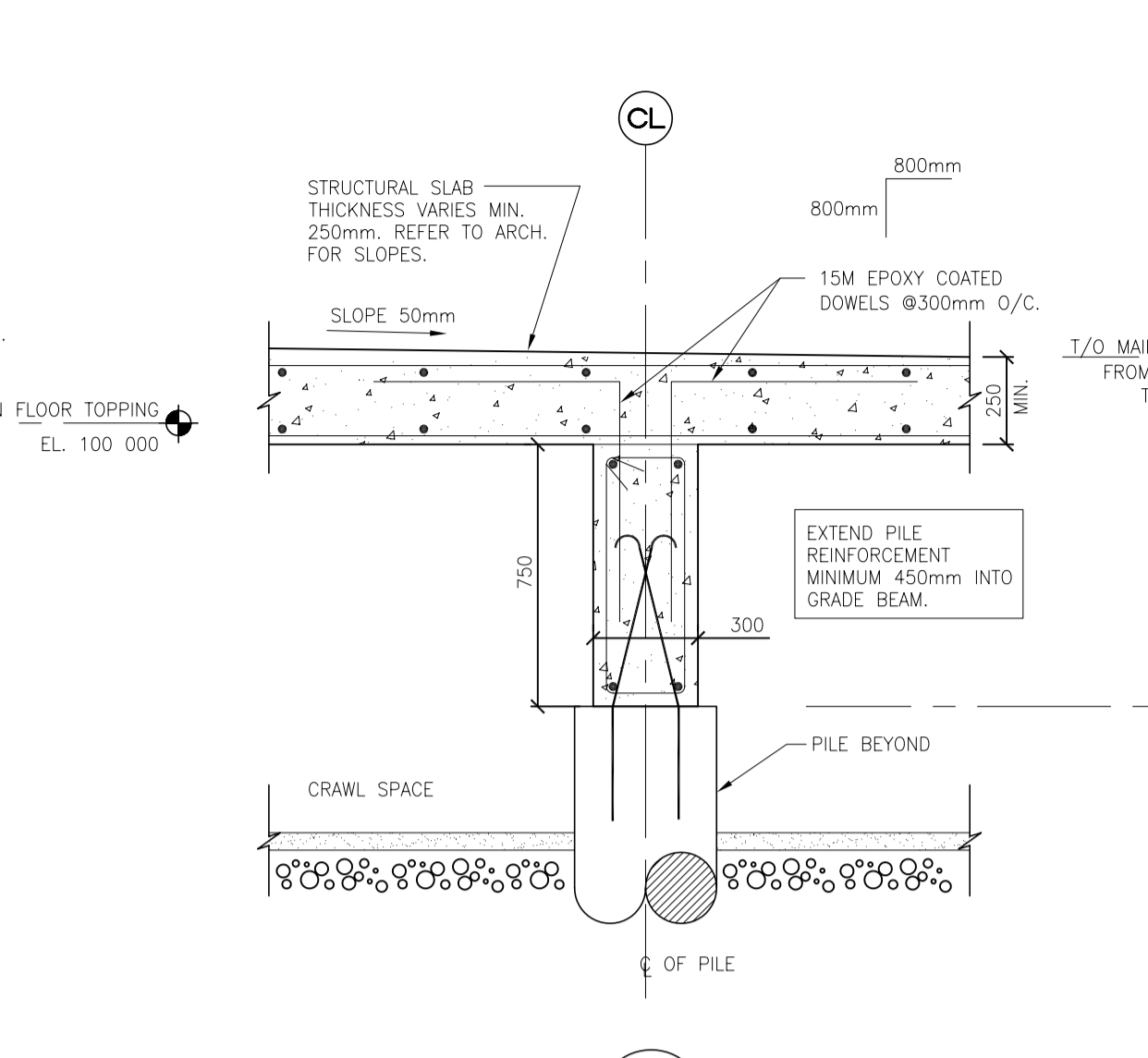

SECTION 4 SCALE: 120

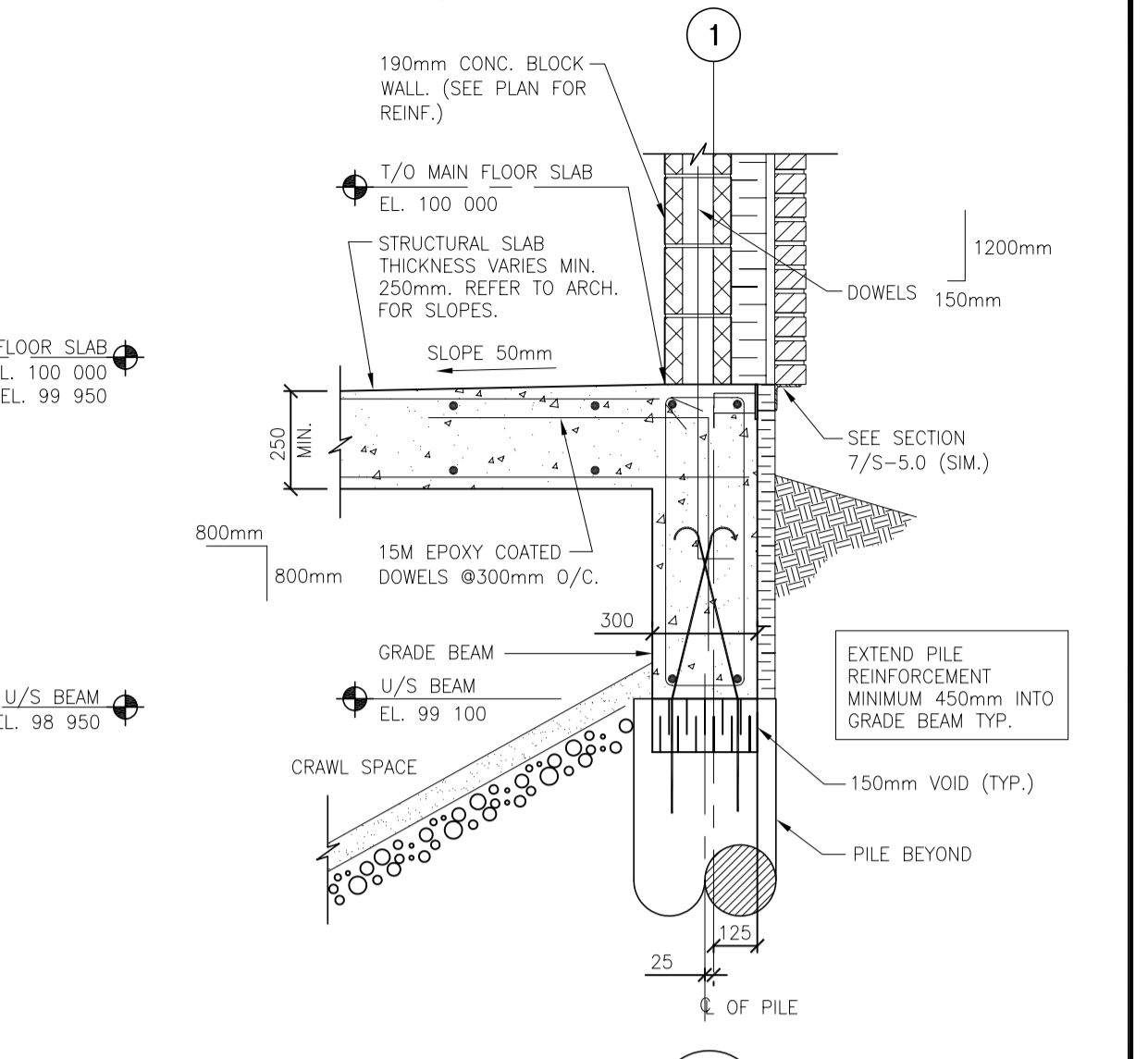

SECTION 5 SCALE: 120

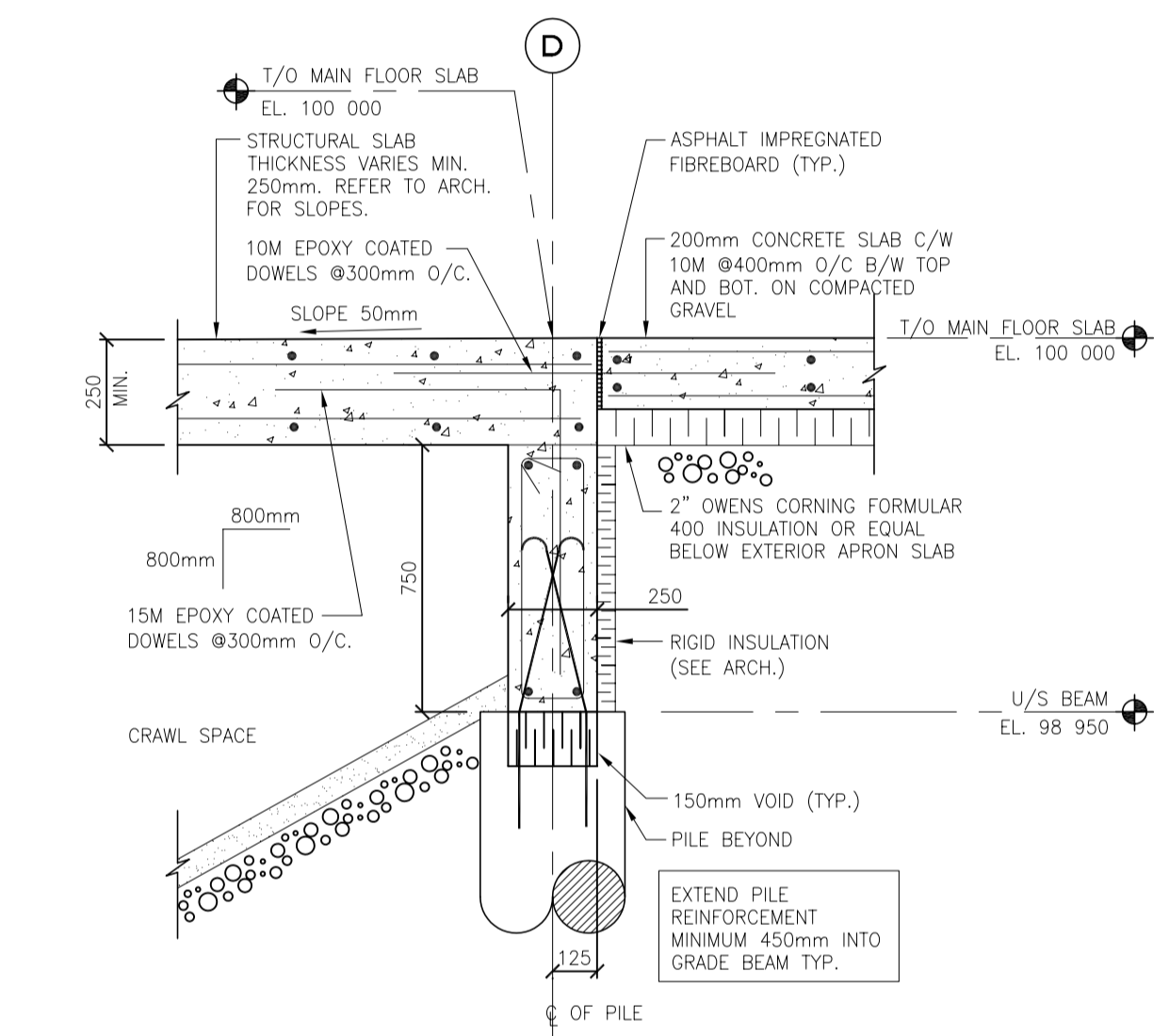

SECTION 6 SCALE: 120

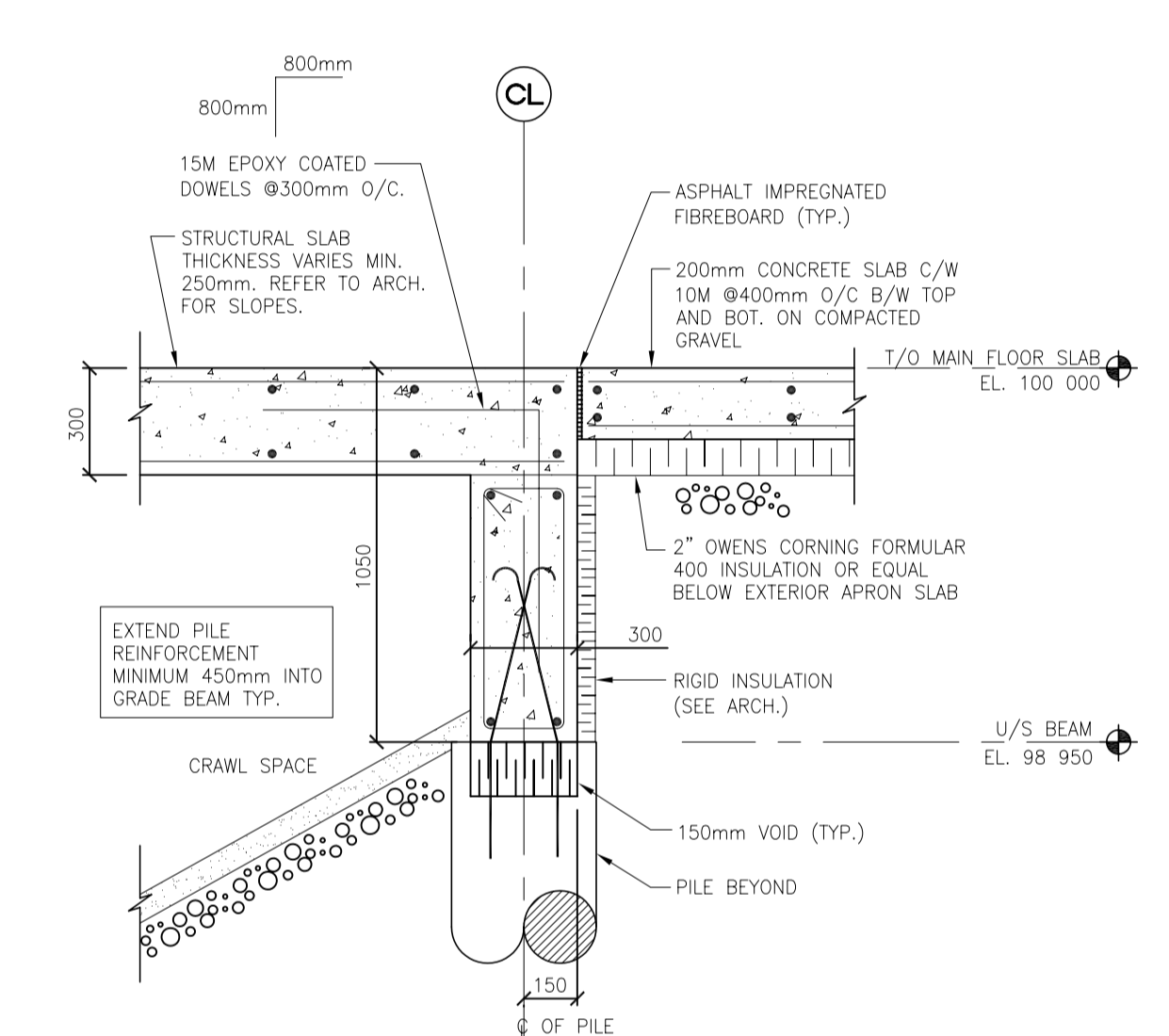

SECTION 7 SCALE: 120

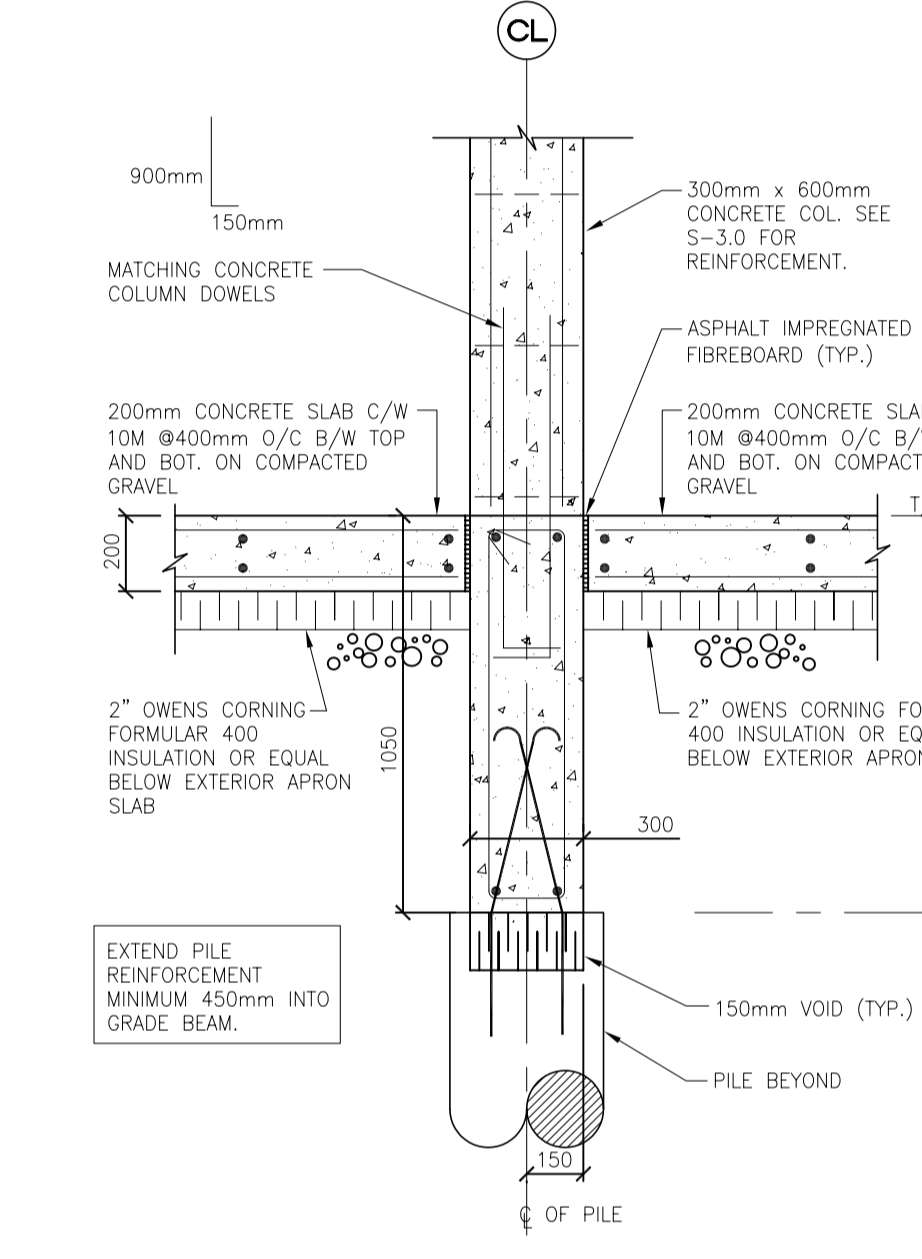

SECTION 8 SCALE: 120

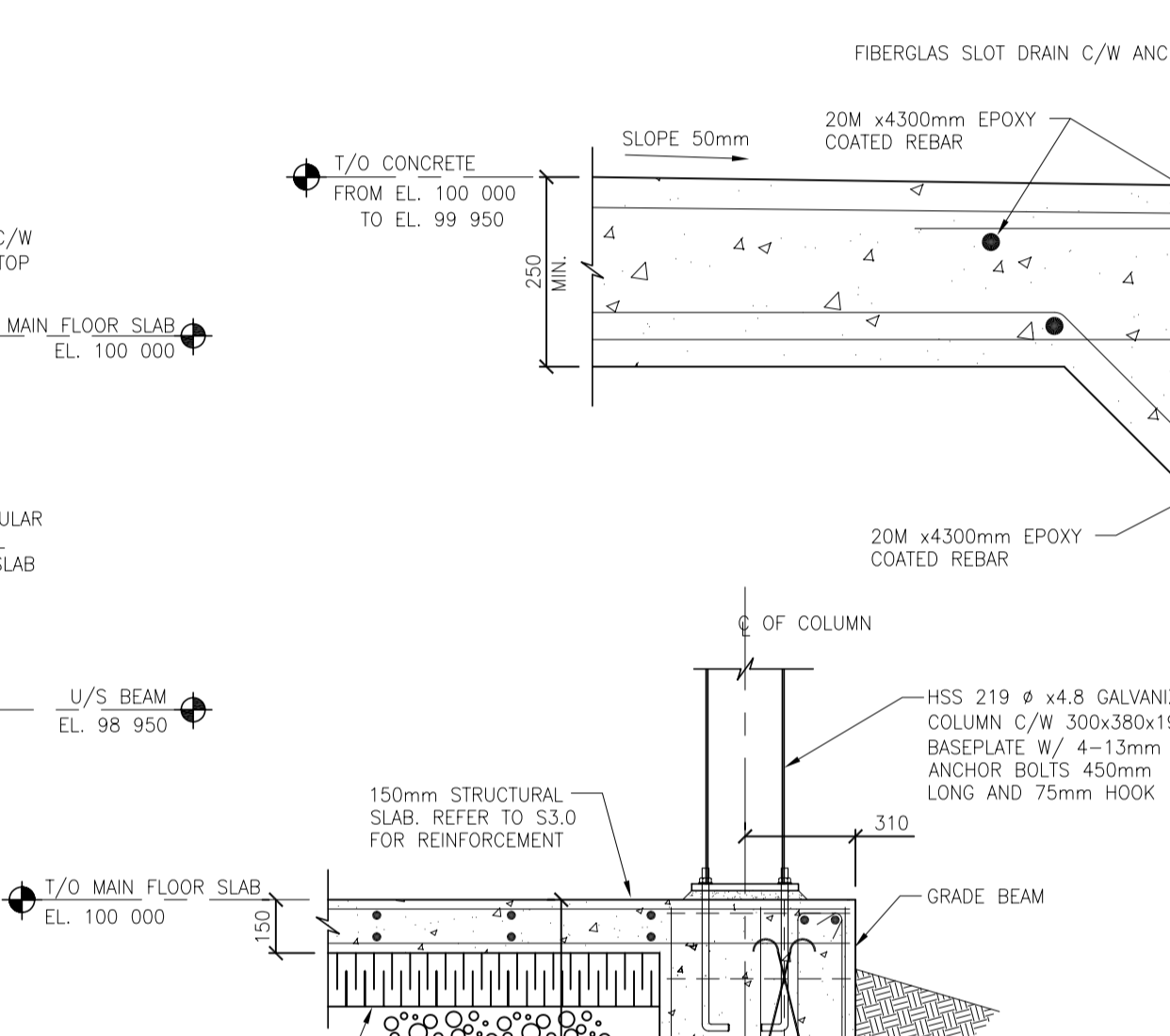

SECTION 9 SCALE: 110

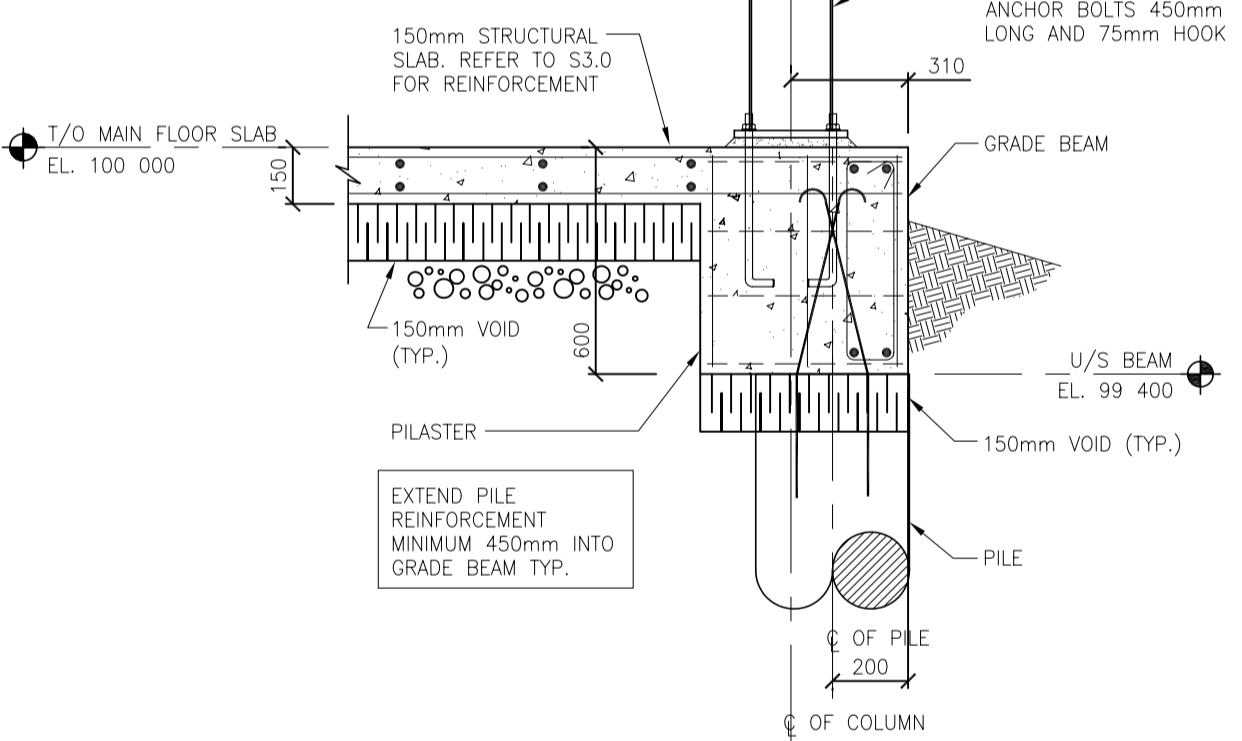

SECTION 10 SCALE: 120

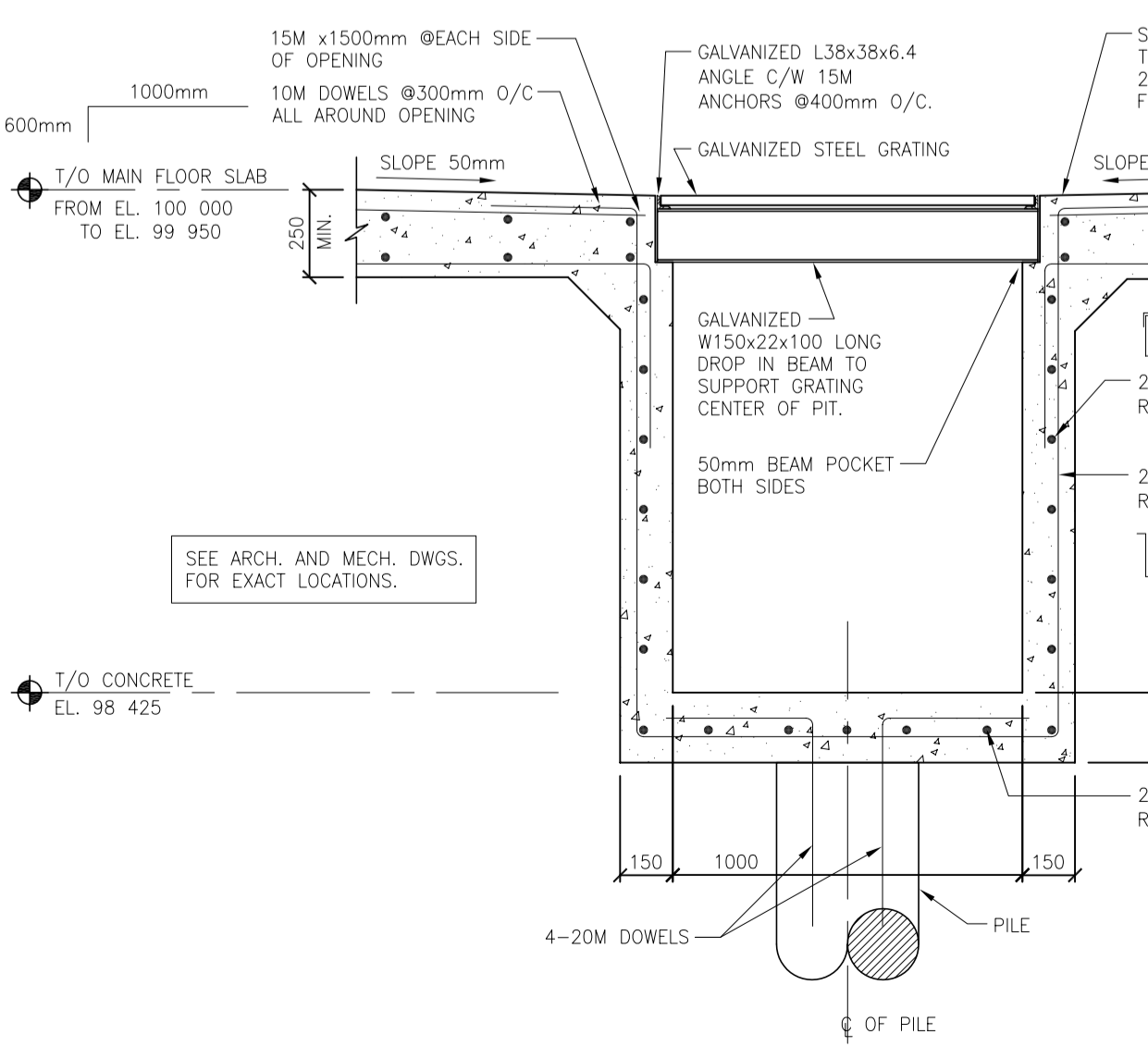

SECTION 11 SCALE: 120

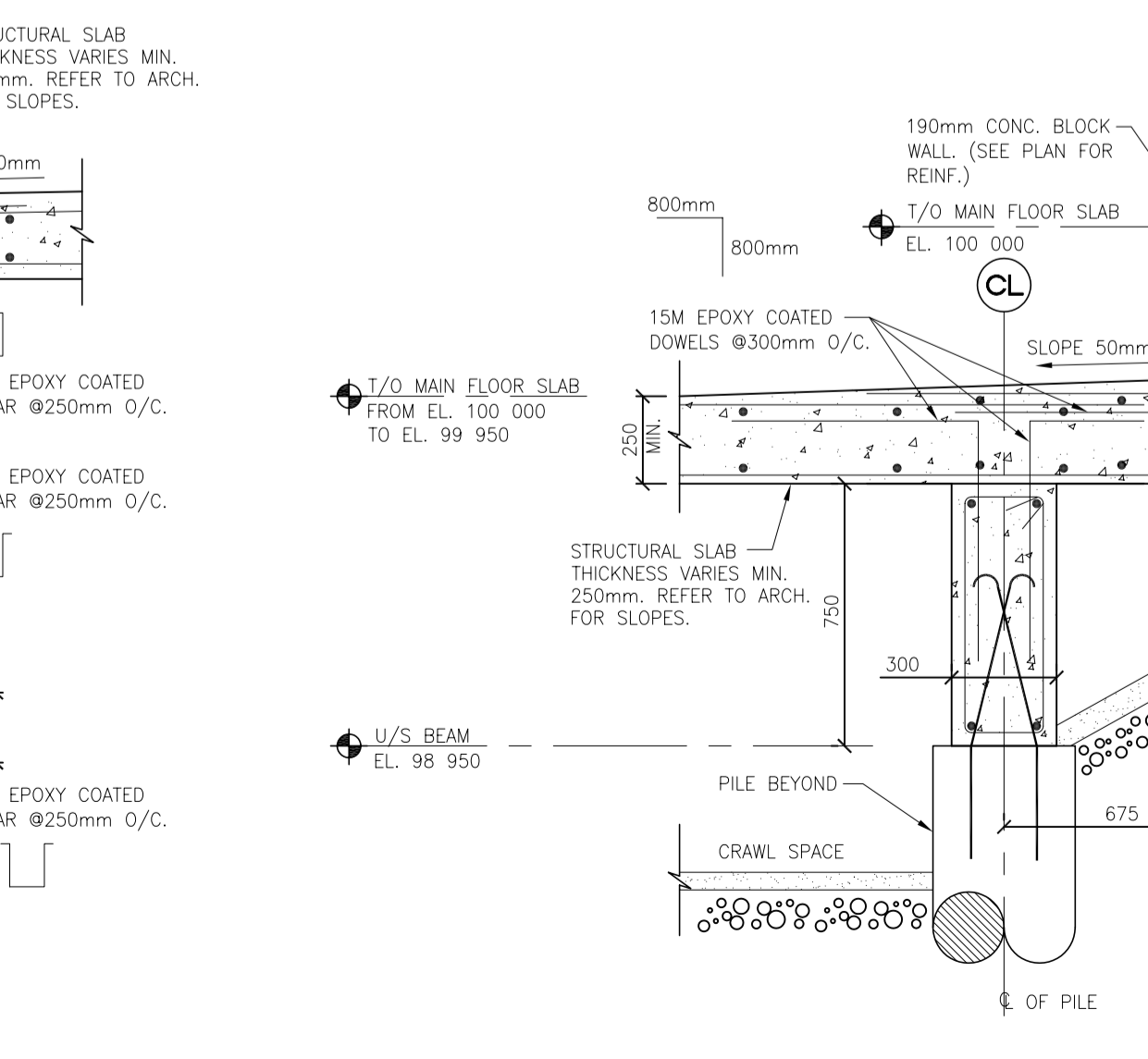

SECTION 12 SCALE: 120

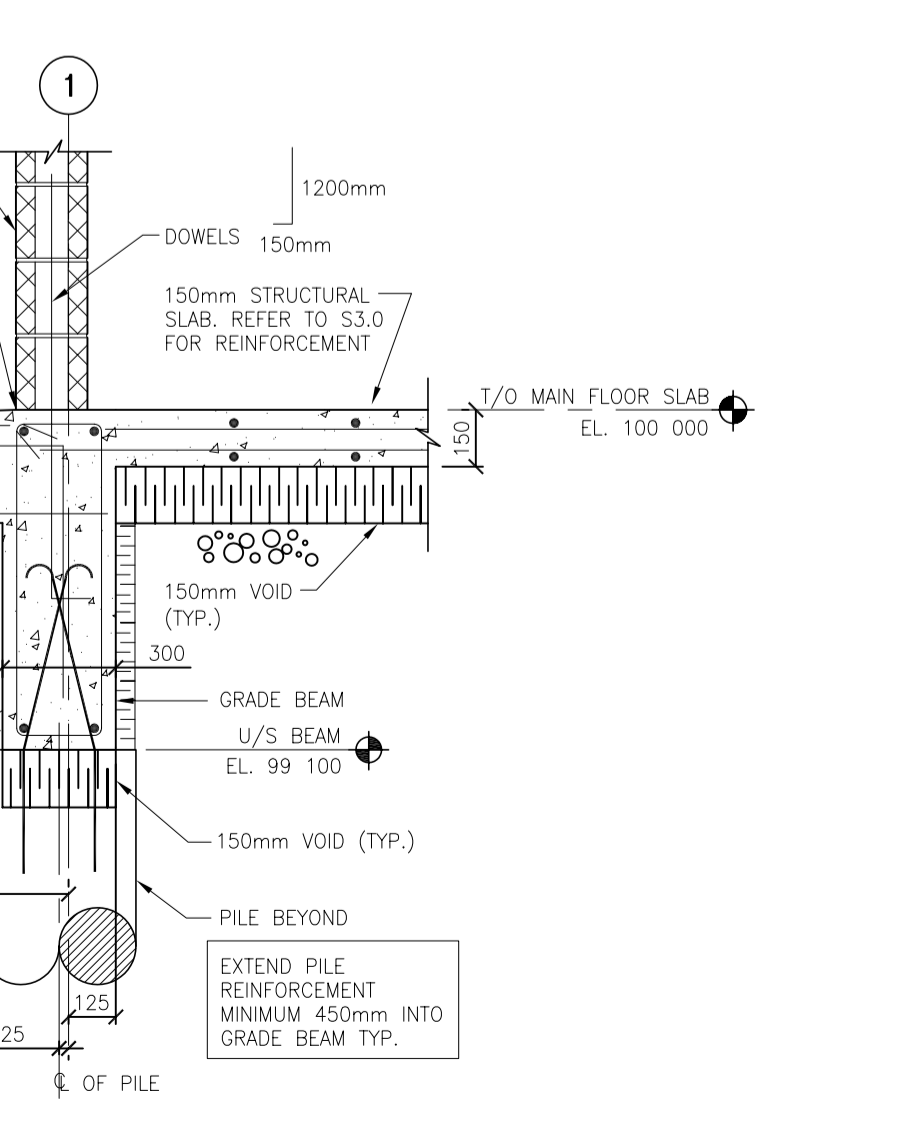

SECTION 13 SCALE: 120

NOTES:

190mm CONC. BLOCK WALL. (SEE PLAN FOR REINF.)  
T/O MAIN FLOOR SLAB EL. 100 000  
STRUCTURAL SLAB THICKNESS VARIES MIN. 250mm. REFER TO ARCH. FOR SLOPES.  
SLOPE 50mm  
15M EPOXY COATED DOWELS @ 300mm O/C  
U/S BEAM EL. 98 950  
PILE BEYOND  
150mm VOID (TYP.)  
EXTEND PILE REINFORCEMENT MINIMUM 450mm INTO GRADE BEAM TYP.

ORIGINAL STAMPED BY: N. MARTINEZ, P. ENG.  
DATE: 2006.07.17

Table with 4 columns: NO., REVISION/DESCRIPTION, BY, DATE. Row 1: 1. ISSUED FOR CLIENT REVIEW, NM, JUNE 23/06. Row 2: 2. ISSUED FOR TENDER, NM, JULY 17/06.

CONSULTANT: TOWER ENGINEERING GROUP  
TOWER PROJECT NO.: 6079  
208 - 897 CORYDON AVE. WINNIPEG, MB. R3M 0W7  
TEL: (204) 925-1150 FAX: (204) 925-1155  
EMAIL: towereng@towereng.ca WEB: www.towereng.ca

APEGA Certificate of Authorization  
Tower Engineering Group Inc.  
No. 1918 Expiry: April 30, 2007

DRAWN BY: SM CHECKED BY: USER APPROVED  
DATE: 2006.07.17

CITY OF WINNIPEG  
PLANNING, PROPERTY & DEVELOPMENT DEPARTMENT  
CIVIC ACCOMMODATIONS DIVISION  
300 - 65 GARRY ST. R3C 4K4

PROJECT: WEST TRANSCONA  
FIRE PARAMEDIC STATION 21

1446 REGENT AVENUE W  
SHEET TITLE: MAIN FLOOR SECTIONS

METRIC  
WHOLE NUMBERS ARE IN MILLIMETRES, DECIMALIZED NUMBERS ARE IN METRES  
SCALE: AS SHOWN PROJECT NO: 2004-058 SHEET NO: S5.1

DRAWING SHEET SIZE: A1 (841mm x 594mm) PLOT 1:1