

STRUCTURAL STEEL

1. Fabricate & erect structural steel to CSA Standard CAN/CSA-S16.1
2. Structural steel shapes and plates shall conform to CSA Standard CAN/CSA-G40.21, Grade 350W and CAN/CSA-G40.21, Grade 350W for H.S.S., Class C.
3. All welding shall be performed by qualified welders fully approved for structural welding by the Canadian Welding Bureau in accordance with CSA Specifications W47 and W59.
4. Design and fabricate all connections for the full strength of the member.
5. Splicing of members not permitted unless otherwise noted.
6. Where beams are continuous over supports, no holes permitted in top flange. Provide 2-10mm (3/8") welded web stiffener plates each side of beam, aligned with column walls.
7. Column base and cap plates shall be welded to columns. Provide 20mm (3/4") thick cap plate c/w 4-20Ø (3/4") bolts for all columns supporting cantilevered beams.
8. Use 90x90x10mm (3 1/2"x3 1/2"x3/8") loose lintel angle in masonry wall spans up to 1200mm (4'-0"). Exterior lintel angle steel shall be hot dipped galvanized.
9. Structural steel erector shall supply and install all temporary guying and bracing necessary to provide stability for the structure as a whole. These shall remain in place until floor slabs are well cured, steel roof deck is fully welded and/or permanent bracing is installed.
10. Steel stairs, handrails, guardrails shall be designed by others. Fabricator shall submit shop drawings under the seal of a Professional Engineer registered in the project Province, to the Architect for approval prior to fabrication.
11. Structural Steel supplier shall submit shop drawings bearing the seal of a Professional Engineer in the project Province showing all design and fabrication details of connections to the Architect for review prior to fabrication.

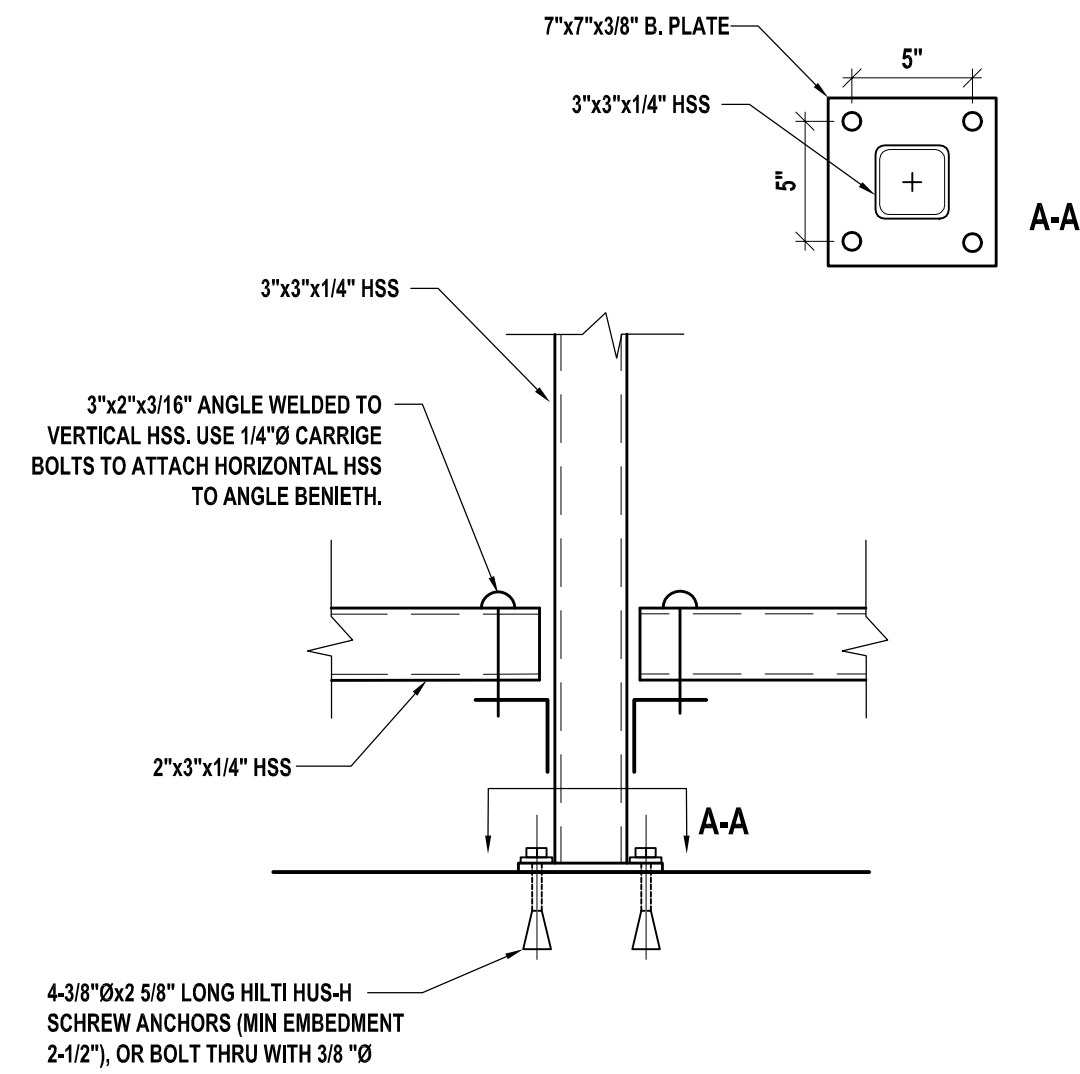

2
S1 S1
3"x3" HSS TO FLOOR CONNECTION (TYP)
1 1/2" = 1'-0"

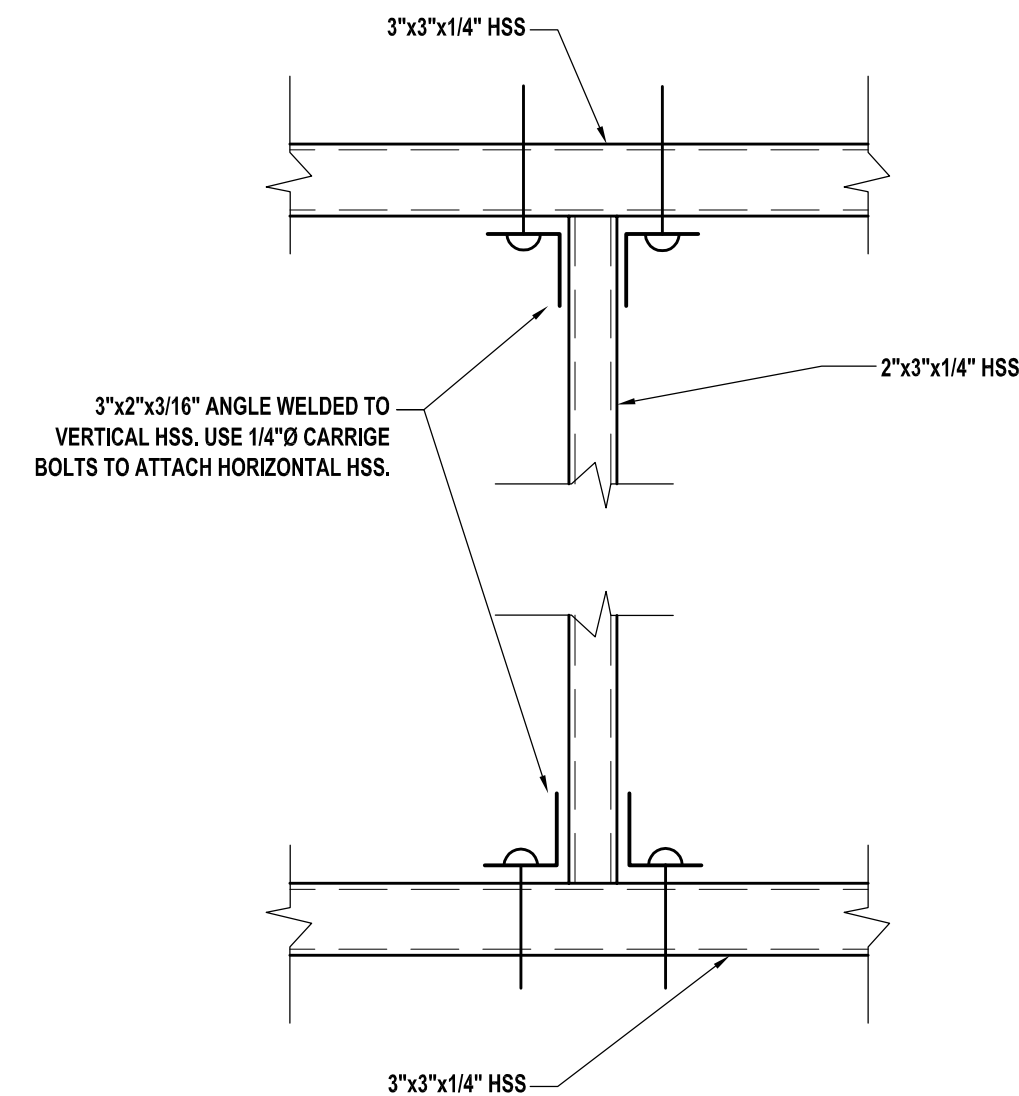

3
S1 S1
2"x3" HSS TO 3"x3" HSS CONNECTION (TYP)
1 1/2" = 1'-0"

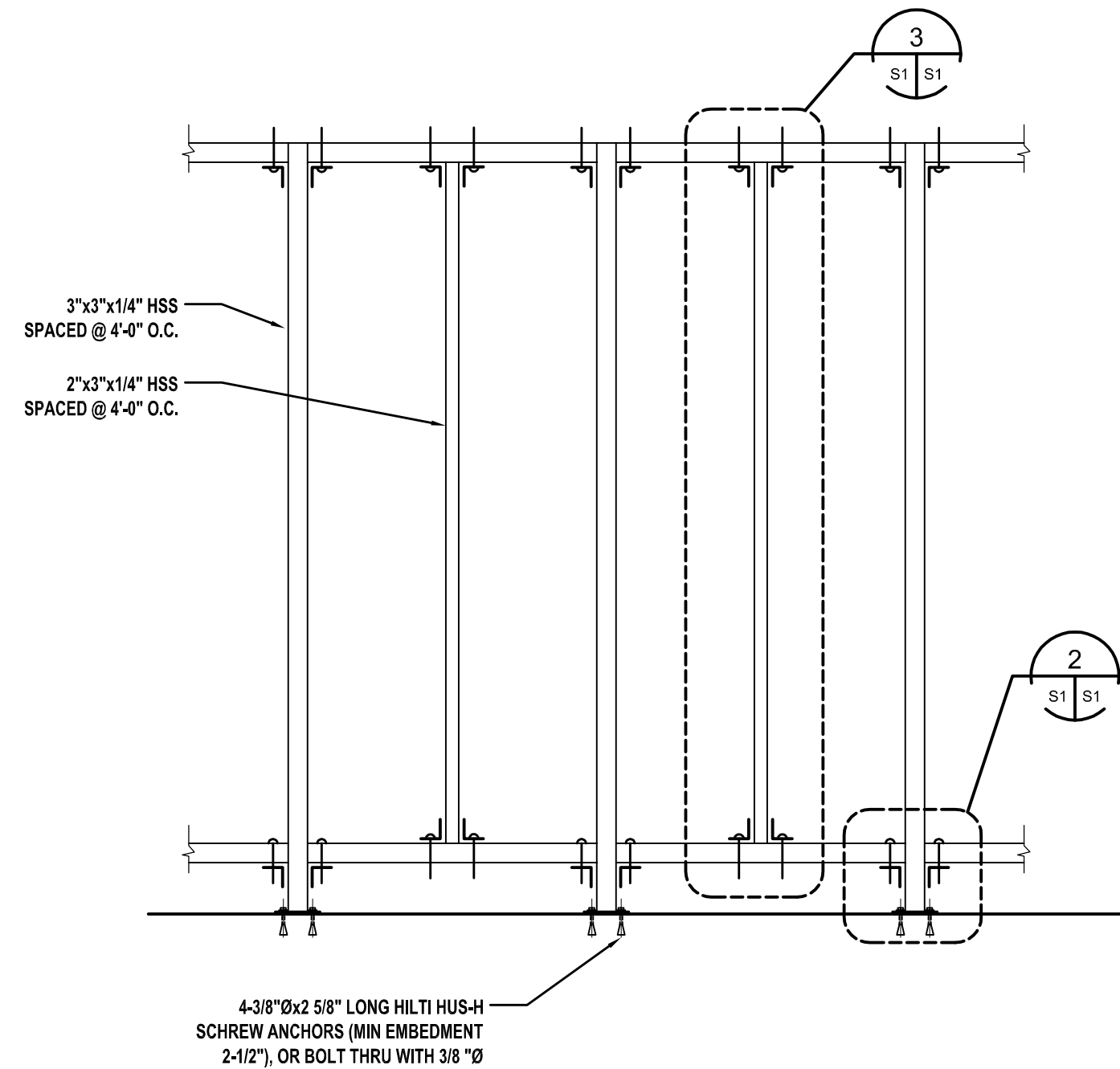

1
S1 S1
TYPICAL WALL ELEVATION
1/2" = 1'-0"

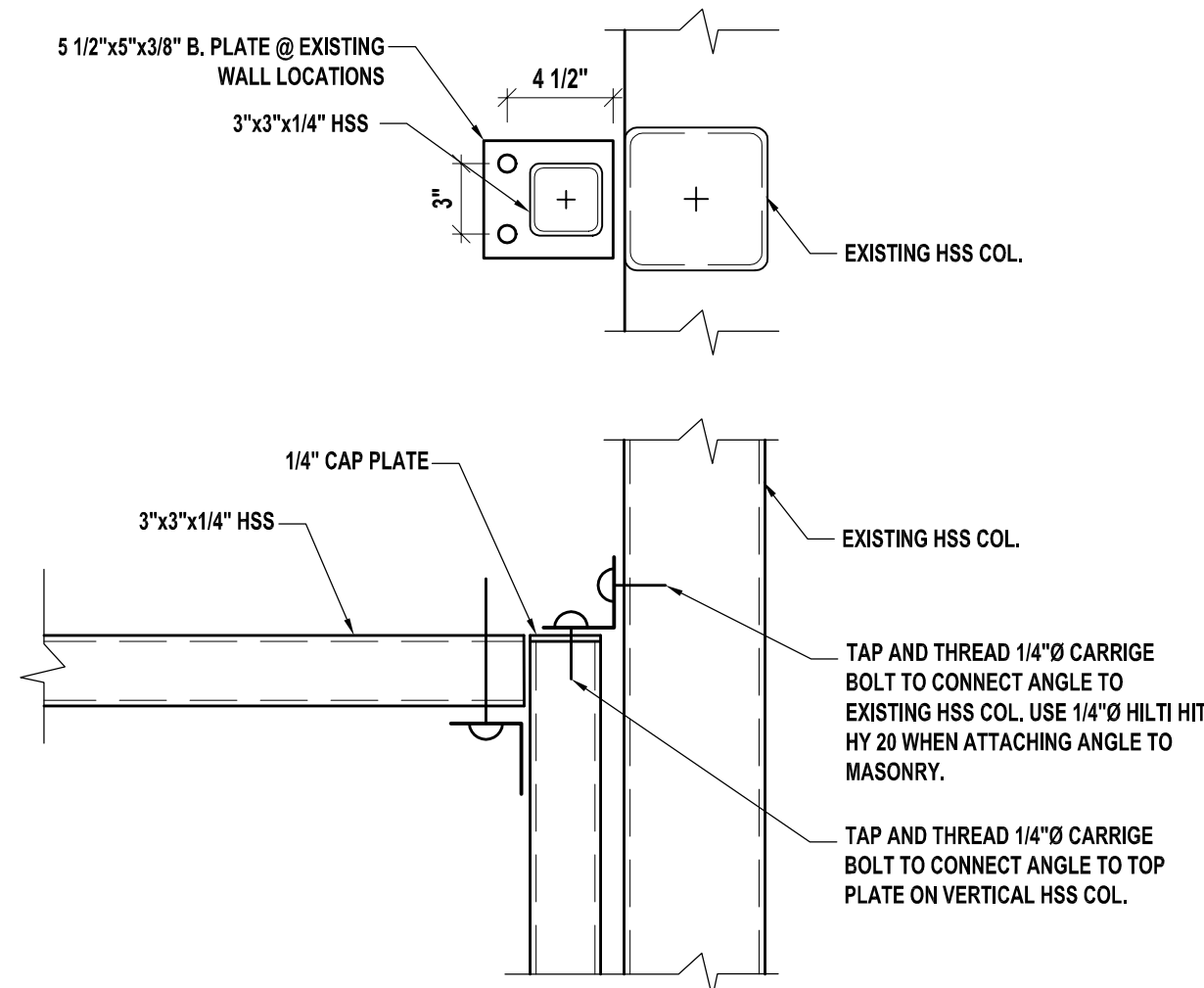

4
S1 S1
EXISTING WALL CONNECTION (TYP)
1 1/2" = 1'-0"

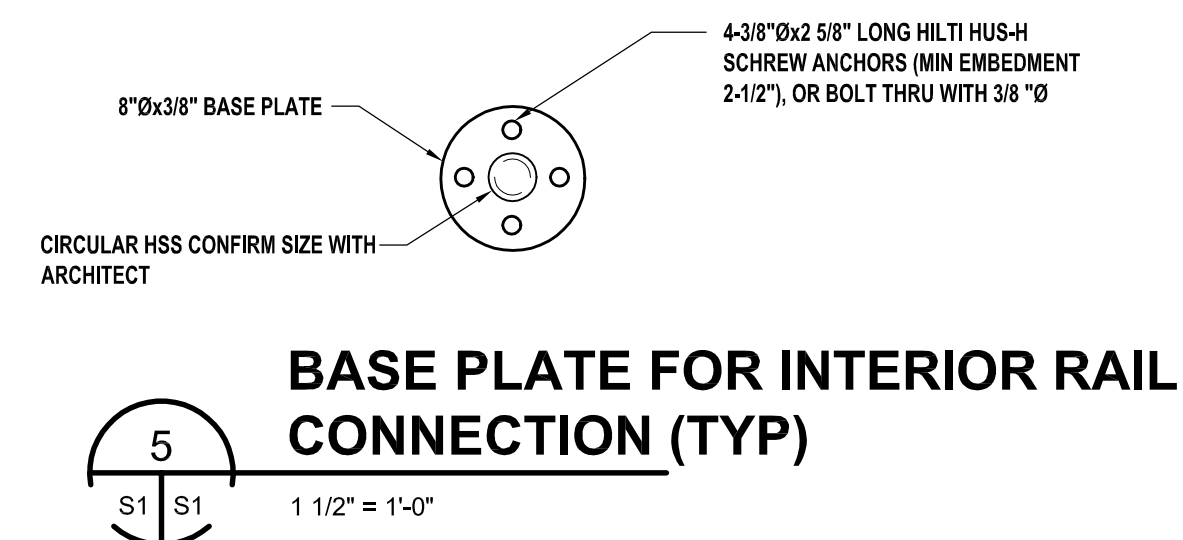

5
S1 S1
BASE PLATE FOR INTERIOR RAIL CONNECTION (TYP)
1 1/2" = 1'-0"

ISSUED FOR TENDER



THE CONTRACTOR IS TO VERIFY DIMENSIONS AND DATA NOTED ON THE STRUCTURAL DRAWINGS WITH CONDITIONS ON THE SITE. CO-ORDINATE ALL DIMENSIONS WITH THE ARCHITECTURAL DRAWINGS, AND IS HELD RESPONSIBLE FOR REPORTING ANY DISCREPANCIES TO THE ENGINEER BEFORE PROCEEDING WITH THE WORK. VARIATIONS AND MODIFICATIONS TO WORK SHOWN ON THE STRUCTURAL DRAWINGS SHALL NOT BE CARRIED OUT WITHOUT WRITTEN PERMISSION FROM THE ENGINEER. THIS DRAWING IS NOT TO BE SCALED.

LD STRUCTURAL ENGINEERS
Lavergne Draward & Associates Inc.
402-138 Portage Avenue East
Winnipeg, Manitoba
R3C 0A1
Tel: 294.7.2222
Fax: 294.7.2522
E: mailgeneral@daeng.ca

PAN-AM POOL INTERIOR WALLS

Sheet Title
CONNECTION DETAILS

Scale: AS SHOWN Date: AUG 14, 2006

File Number: 5096 Sheet Number: S1