

Appendix E

McPhillips Engine Inspection Reports

Bore Scope Results

Engine #: 1

Location: McPhillips Pump Station

Date: April 7, 2006

<p>#1 Left Cylinder Liner – light scuffing 5:00-3:00 Cylinder Head - good Exhaust Valve - good Intake Valve - good</p> <p style="margin-left: 150px;"><i>↳ is generalized scratches.</i></p>	<p>#1 Right Cylinder Liner – good Cylinder Head - good Exhaust Valve - good Intake Valve - good</p>
<p>#2 Left Cylinder Liner – liner is like brand new Cylinder Head - good Exhaust Valve - good Intake Valve - good</p>	<p>#2 Right Cylinder Liner - good Cylinder Head - good Exhaust Valve - good Intake Valve - good</p>
<p>#3 Left Cylinder Liner – scratches from 12:00-1:00 Cylinder Head - excellent Exhaust Valve – good Intake Valve – some carbon B/U not excessive</p>	<p>#3 Right Cylinder Liner – scratches & scuffing 12:00-1:00 Cylinder Head - good Exhaust Valve - good Intake Valve - good</p>
<p>#4 Left Cylinder Liner – liner is like brand new Cylinder Head – is perfect Exhaust Valve – good Intake Valve - good</p>	<p>#4 Right Cylinder Liner - good Cylinder Head - good Exhaust Valve – like brand new Intake Valve – like brand new</p>
<p>#5 Left Cylinder Liner – good Cylinder Head - good Exhaust Valve – right valve a lot of <u>recession</u> Intake Valve - good</p>	<p>#5 Right Cylinder Liner - good Cylinder Head - good Exhaust Valve - good Intake Valve - good</p>
<p>#6 Left Cylinder Liner – good Cylinder Head - good Exhaust Valve - good Intake Valve - good</p>	<p>#6 Right Cylinder Liner - good Cylinder Head - good Exhaust Valve - good Intake Valve - good</p>

RIGHT

LEFT

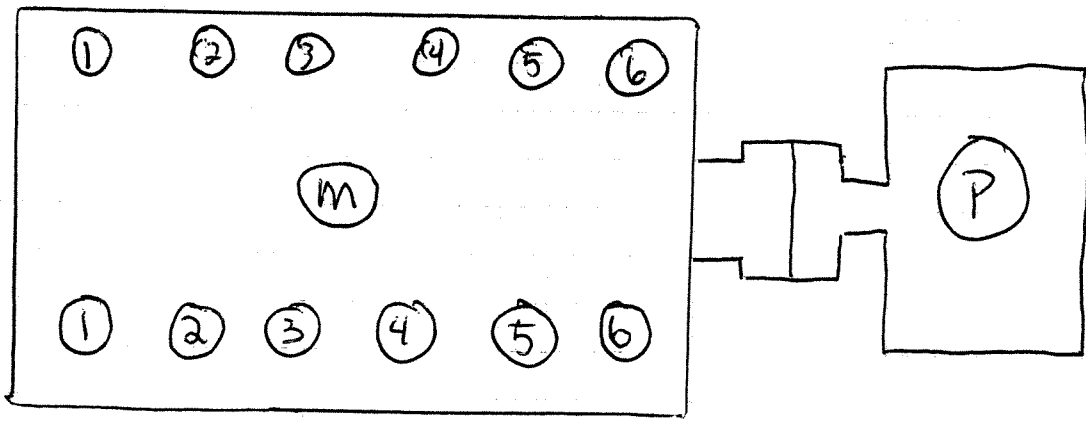

Bore Scope Results

Engine #: 5

Location: McPhillips Pump Station

Date: April 7, 2006

<p>#1 Left Cylinder Liner – light scuffing 9:00-5:00 Cylinder Head - good Exhaust Valve - good Intake Valve - good</p>	<p>#1 Right Cylinder Liner – good Cylinder Head - good Exhaust Valve - good Intake Valve - good</p>
<p>#2 Left Cylinder Liner – light scuffing , some scratches Cylinder Head - good Exhaust Valve - good Intake Valve - good</p>	<p>#2 Right Cylinder Liner - good Cylinder Head - good Exhaust Valve – high wear on right valve Intake Valve - good</p>
<p>#3 Left Cylinder Liner – good Cylinder Head - excellent Exhaust Valve – good Intake Valve – good</p>	<p>#3 Right Cylinder Liner – good Cylinder Head - good Exhaust Valve - good Intake Valve - good</p>
<p>#4 Left Cylinder Liner – good Cylinder Head – good Exhaust Valve – left valve cracked , some recession Intake Valve - good</p>	<p>#4 Right Cylinder Liner - good Cylinder Head - good Exhaust Valve – like brand new Intake Valve – like brand new</p>
<p>#5 Left Cylinder Liner – light scuffing 10:00 – 3:00 Cylinder Head - good Exhaust Valve – good Intake Valve - good</p>	<p>#5 Right Cylinder Liner - good Cylinder Head - good Exhaust Valve – leaking valve seal on left valve Intake Valve - good</p>
<p>#6 Left Cylinder Liner – light scuffing 12:00-1:00 Cylinder Head - good Exhaust Valve - good Intake Valve - good</p>	<p>#6 Right Cylinder Liner - good Cylinder Head - good Exhaust Valve - good Intake Valve - good</p>

RIGHT

LEFT

