

**C SECTION**  
WJ-F0105 1:50  
WJ-S0101  
WJ-S0111  
WJ-S0121  
(REVISED FOR IFT FEB. 22/07 DK)

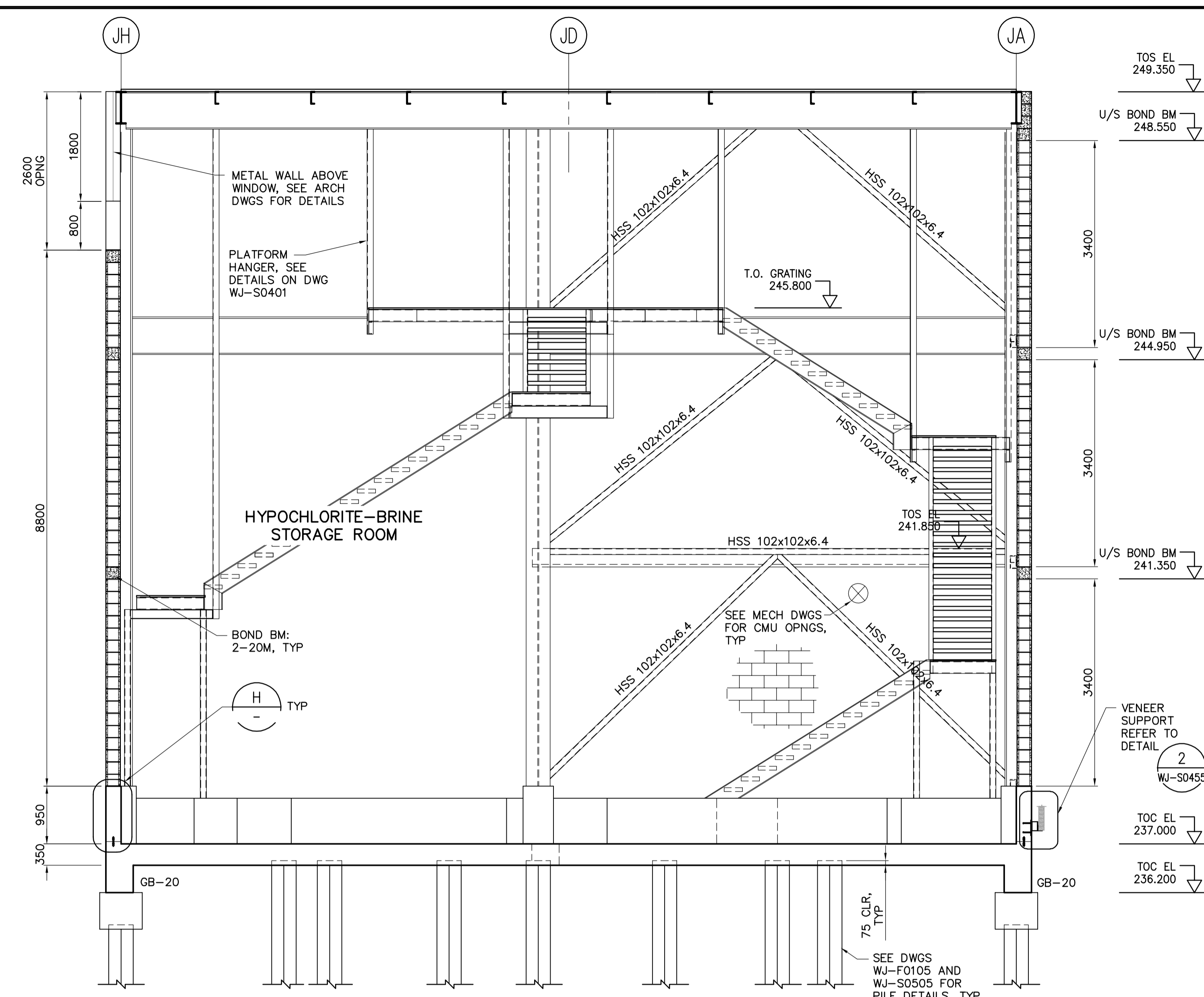

**D SECTION**  
WJ-F0105 1:50  
WJ-S0101  
WJ-S0111  
WJ-S0121  
(REVISED FOR IFT FEB. 22/07 DK)

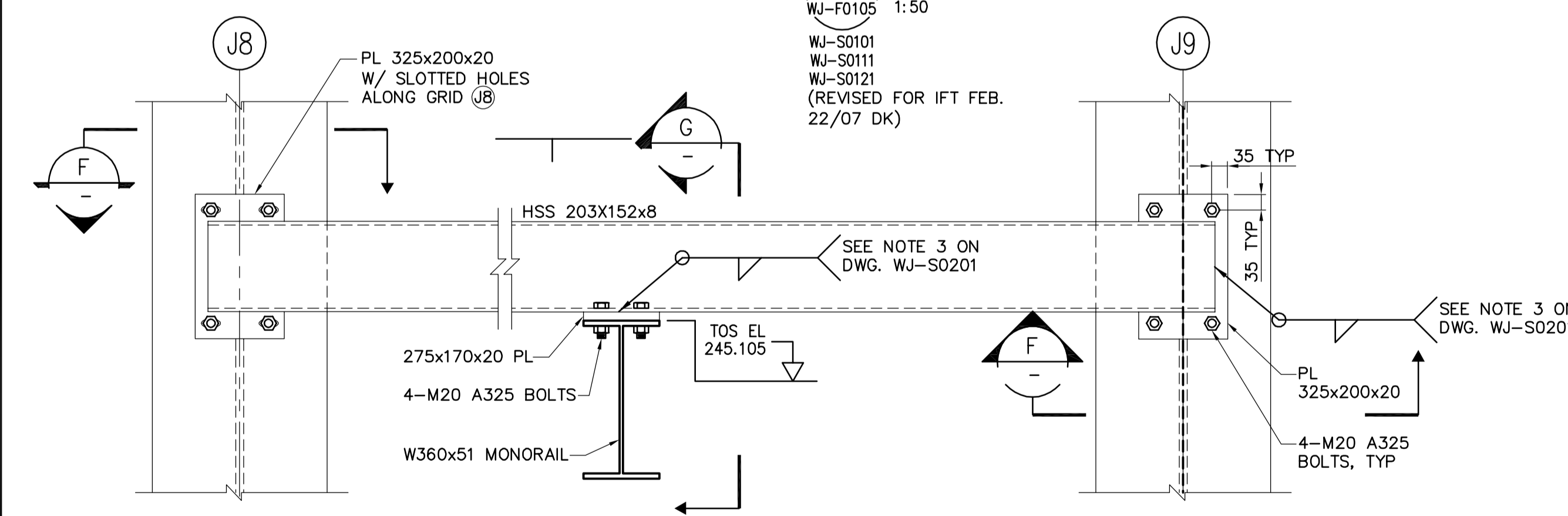

**NOTE:**  
1. CMU WALL NOT SHOWN FOR CLARITY.

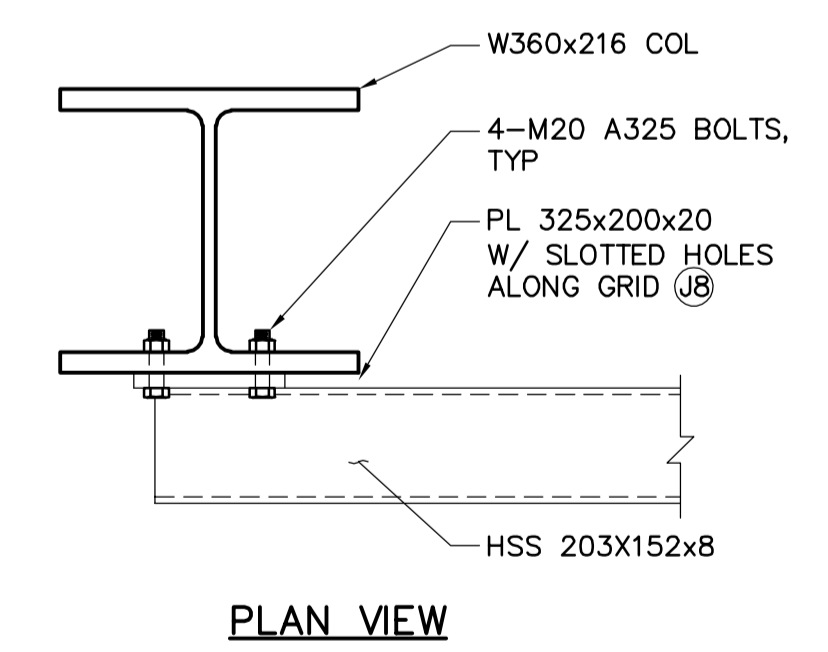

**NOTE:**  
1. CMU WALL NOT SHOWN FOR CLARITY.

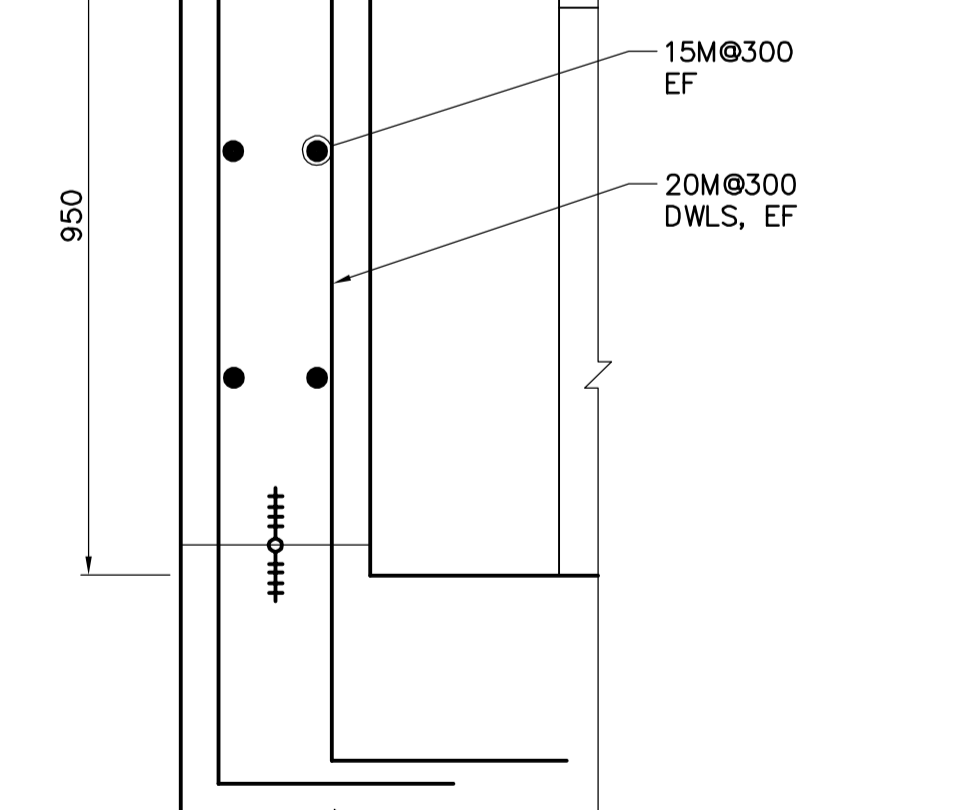
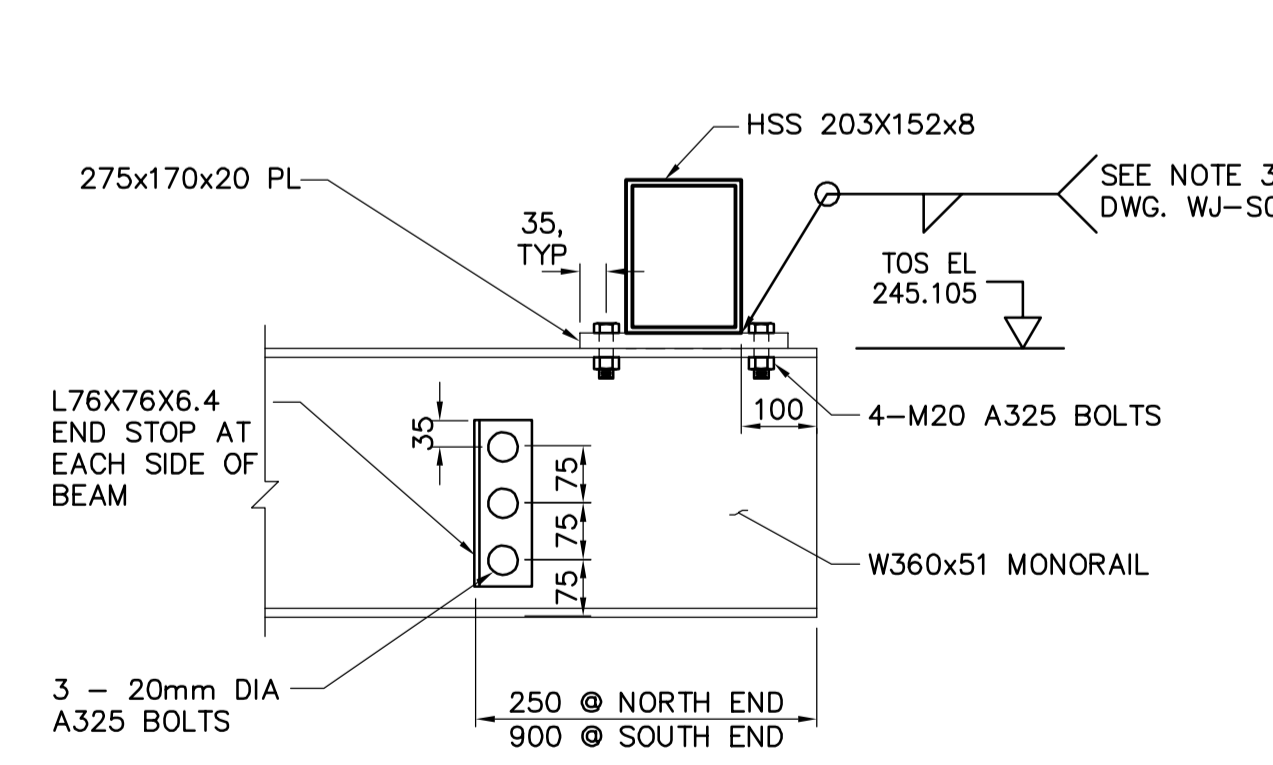

**E SECTION**  
WJ-S0121 1:10

**F SECTION**  
1:10

**G SECTION**  
1:10

**H SECTION**  
1:10  
(REVISED FOR IFT FEB. 22/07 DK)

<p><b>Certificate of Authorization</b> CH2M HILL Canada Ltd. No. 1441 Expiry: April 30, 2007</p>	B.M. ELEV.	<p>Frederickson Cooper ARCHITECTS</p>	<p>EarthTech A 100 International Ltd. Company</p>	ENGINEER'S SEAL	<p><b>THE CITY OF WINNIPEG</b> WATER AND WASTE DEPARTMENT ENGINEERING DIVISION</p> <p>WATER TREATMENT PLANT SODIUM HYPOCHLORITE BUILDING SODIUM HYPOCHLORITE AND CHEMICAL STORAGE BUILDINGS</p> <p>STRUCTURAL SODIUM HYPOCHLORITE BUILDING SECTIONS</p>	CITY FILE NUMBER
	DESIGNED BY: MH			CHECKED BY: AP		ORIGINAL SIGNED BY: D. KRUGER
	DRAWN BY: CR	APPROVED BY: AHL	2007/01/31	CITY DRAWING NUMBER		
	SCALE: AS NOTED	RELEASED FOR CONSTRUCTION BY: R. SOROKOWSKI	CONSULTANT DRAWING NO. WJ-S0203	1-0601J-A-S0203-001-000		
	NO. REVISIONS	DATE BY	DATE	DATE		