

NOTES:

1. REMOVE EX. CURB AND INSTALL NEW 150mm BARRIER CURB
2. PAVEMENT REPAIRS SHOWN ARE ONLY A REPRESENTATIVE SAMPLE OF THE TENDERED QUANTITIES
3. ALL RADIUS CURB UNDER 15.0m SHALL BE REPLACED AS MODIFIED BARRIER CURB AS DIRECTED BY THE CONTRACT ADMINISTRATOR
4. BOULEVARD RESTORATION AS DIRECTED BY THE CONTRACT ADMINISTRATOR
5. ASPHALT OVERLAY MINIMUM THICKNESS 100mm OR AS DIRECTED BY CONTRACT ADMINISTRATOR

CHAINAGE ALONG CENTER LINE OF N. BOUND LANE

OAK POINT HWY

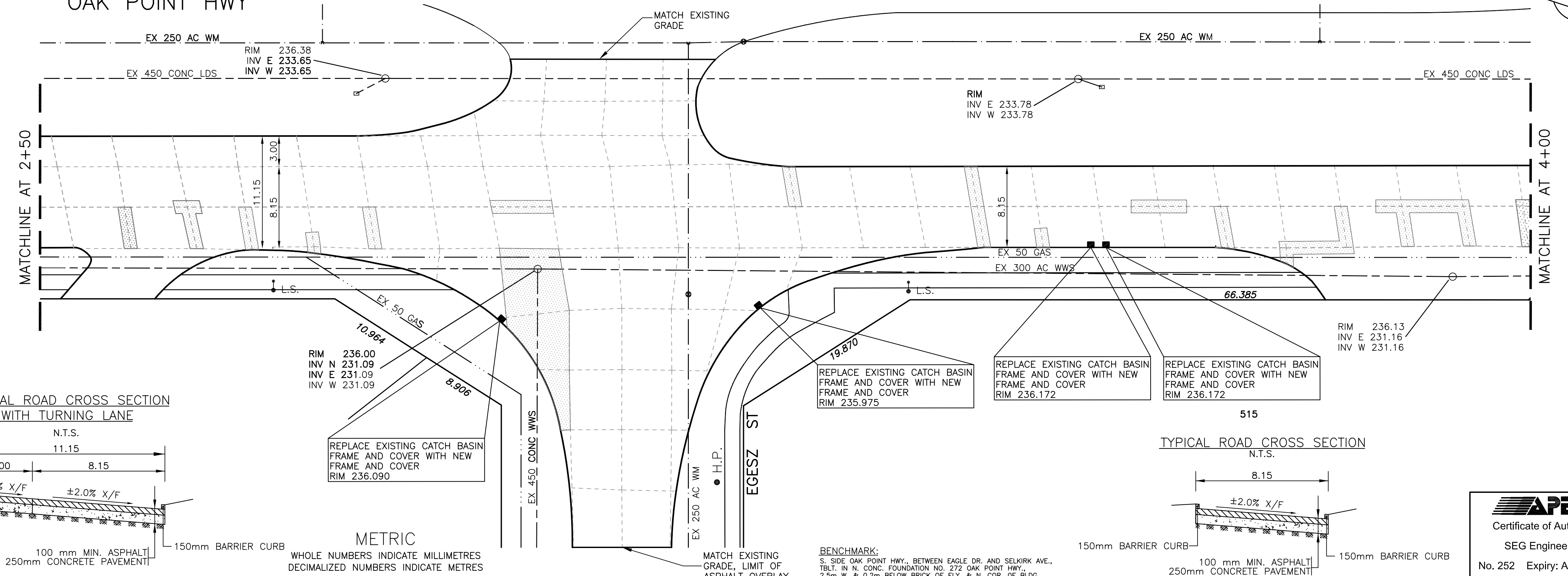

TYPICAL ROAD CROSS SECTION WITH TURNING LANE

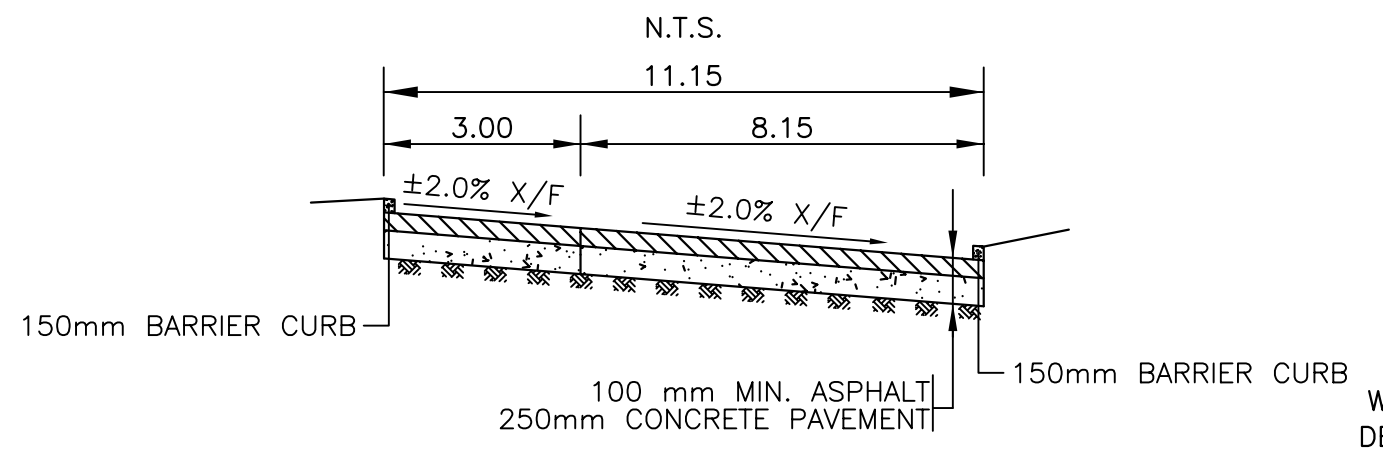

TYPICAL ROAD CROSS SECTION

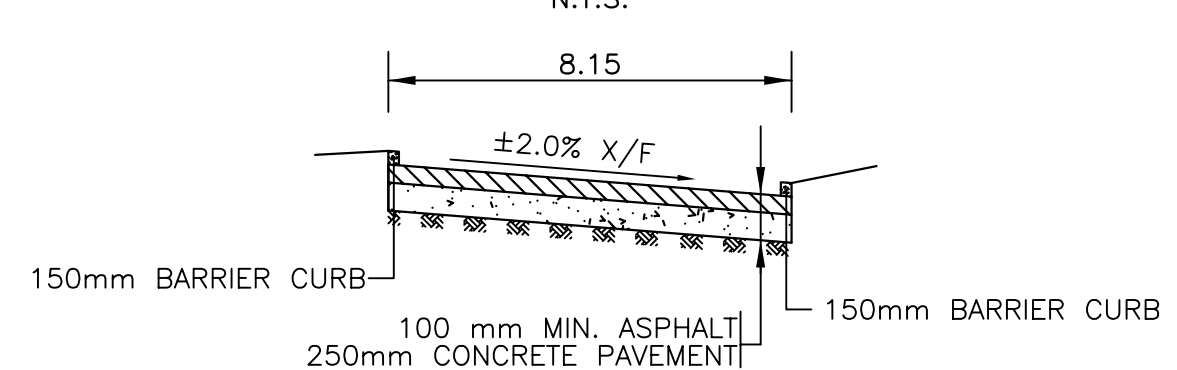

WATERMAIN		HYDRO		CENTER LINE	
---	HYDRANT	---	M.T.S.	---	GUTTER LINE
---	VALVE	---	CONCRETE	---	MEDIAN LINE
---	LAND DRAINAGE SEWER	---	ASPHALT	---	WATERMAIN
---	WASTE WATER SEWER	---	PROPERTY LINE	---	VALVE
○	MANHOLE	⊕	SURVEY BAR	---	LAND DRAINAGE SEWER
□	CATCH BASIN	⊕	CURB STOP	---	WASTE WATER SEWER
△	CURB INLET	⊕	C.B. LEAD	---	JUNCTIONS
---	TRAFFIC SIGNAL	---	SIDEWALK	---	CULVERT
---	STEAM HT.	---	SIDEWALK RAMP	---	
---	GAS	---	ELEVATIONS	(32.55)	
---	EXISTING	---	LEGEND - PLAN	PROPOSED	EXISTING
---	LEGEND - PLAN	---	PROPOSED	EXISTING	LEGEND - PROFILE
---	PROPOSED	---	PROPOSED	EXISTING	PROPOSED

LOCATION APPROVED

SUPPLY U/G STRUCTURES DATE

NOTE: LOCATION OF UNDERGROUND STRUCTURES AS SHOWN ARE BASED ON THE BEST INFORMATION AVAILABLE BUT NO GUARANTEE IS GIVEN THAT ALL EXISTING UTILITIES ARE SHOWN OR THAT THE GIVEN LOCATIONS ARE EXACT. CONFIRMATION OF EXISTENCE AND EXACT LOCATION OF ALL SERVICES MUST BE OBTAINED FROM THE INDIVIDUAL UTILITIES BEFORE PROCEEDING WITH CONSTRUCTION.

NO.	REVISIONS	DATE	BY

SEG ENGINEERING INC.
200 TACHE AVENUE
WINNIPEG, MANITOBA
(204)-233-2113

DESIGNED BY: R.H/S.M.
CHECKED BY: S.M.
DRAWN BY: R.H.
APPROVED BY: I.McK.
HOR. SCALE: 1:250
VERT. SCALE: 1:10
RELEASED FOR CONSTRUCTION: DATE
ORIGINALLY SIGNED BY: DATE

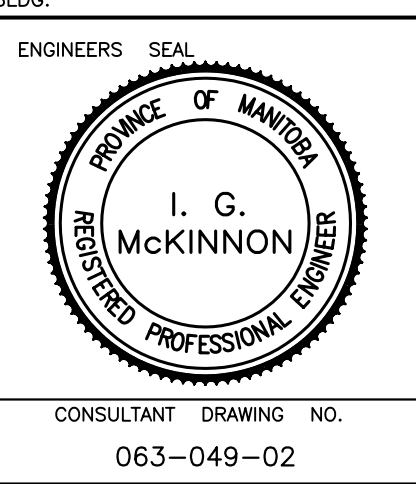

THE CITY OF WINNIPEG
PUBLIC WORKS DEPARTMENT

2007 REGIONAL STREETS
OAK POINT HIGHWAY (NORTH BOUND)
FROM STATION 2+50
TO STATION 4+00

CITY DRAWING NO. P-3283-02
SHEET 2 OF 10
302-2007

CONSULTANT DRAWING NO. 063-049-02