

**Barkman Roman Pisa Retaining Wall System c/w Roman Coping**

**All Materials and Installation To Manufacturer's Specifica Supply Shop Drawings**

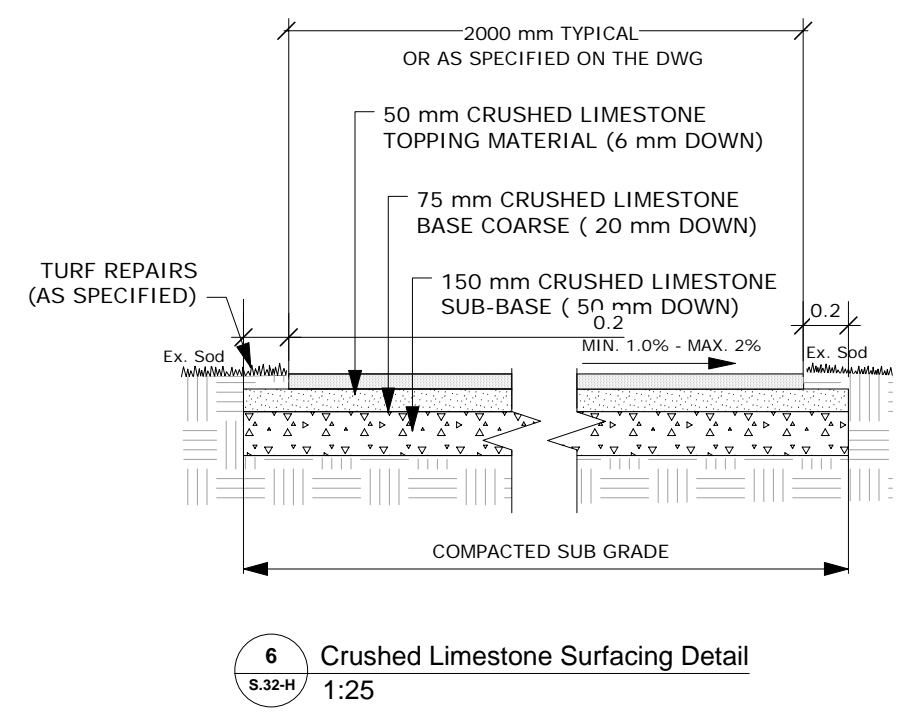

CONTRACTOR TO CONFIRM ALL DIMENSIONS AND REPORT ANY DISCREPANCIES TO CONTRACT ADMINISTRATOR PRIOR TO CONSTRUCTION. LOCATION OF UNDERGROUND STRUCTURES AS SHOWN ARE BASED ON THE BEST INFORMATION AVAILABLE BUT NO GUARANTEE IS GIVEN THAT ALL EXISTING UTILITIES ARE SHOWN OR THAT THE GIVEN LOCATIONS ARE EXACT. CONFIRMATION OF EXISTENCE AND EXACT LOCATION OF ALL SERVICES MUST BE OBTAINED FROM THE INDIVIDUAL UTILITIES BEFORE PROCEEDING WITH CONSTRUCTION.

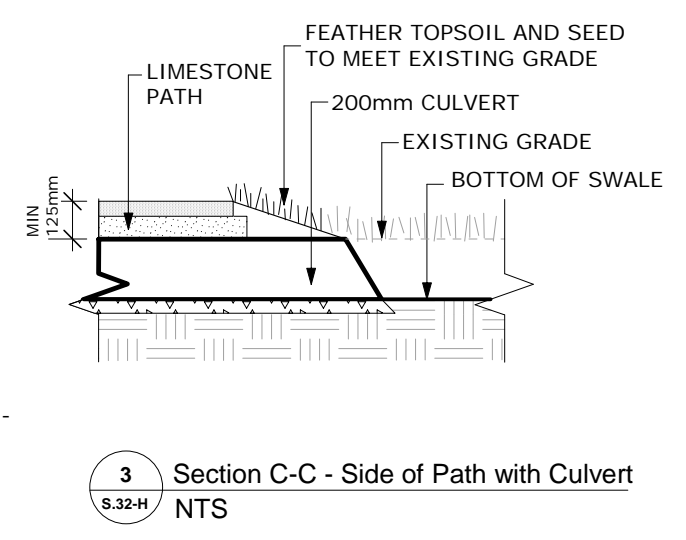
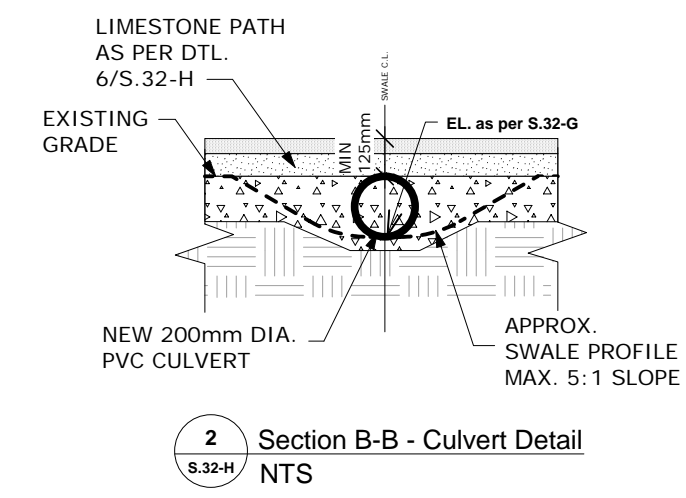

THE CITY OF WINNIPEG  
Planning, Property and Development Department  
Planning and Land Use Division  
Unit 15 - 30 Fort Street, Winnipeg, MB, (R3C 4X5)

|              |          |             |  |
|--------------|----------|-------------|--|
| DESIGNED BY  | CH/DB    | CHECKED BY  |  |
| DRAWN BY     | CH/SP    | APPROVED BY |  |
| HORIZ. SCALE | As Noted |             |  |
| VERT. SCALE  |          |             |  |
| DATE         | July/07  |             |  |

|  |      |
|--|------|
| MANAGER,<br>PARK AND OPEN SPACES           | DATE |
| MANAGER,<br>PLANNING AND LAND USE DIVISION | DATE |

|                      |   |
|----------------------|---|
| DRAWING TITLE        | <b>SHAMROCK SCHOOL SITE REDEVELOPMENT</b> |
| DRAWING NO.          | <b>S.32-H</b>                             |
| CONSTRUCTION DETAILS |   |
| SITE ADDRESS         | 831 Beaverhill Rd                         |
| BID OPPORTUNITY NO.  | <b>309-2007</b>                           |