

AQUEDUCT CROSSING NOTES:

CONTENTS TO BE HANDLED:	EFFLUENT
MAXIMUM OPERATING PRESSURE:	450 KPa (65 psi)
MAXIMUM SURGE AND TEST PRESSURE:	1000 KPa (145 psi)
MAXIMUM OPERATING TEMPERATURE:	20°C
MINIMUM OPERATING TEMPERATURE:	4°C
PIPING MATERIALS:	CARRIER CASING
NOMINAL DIAMETER:	250 mm 350 mm
OUTSIDE DIAMETER:	273 mm 355 mm
MATERIAL:	HDPE STEEL
SPECIFICATION AND GRADE:	ASTM D1784
WALL THICKNESS:	30.3 mm 9.5 mm MIN.
TYPE OF JOINT:	BUTT FUSION WELDED
COATING:	NA MIN. YIELD STRENGTH 241 MPa
METHOD OF INSTALLATION:	TRENCHLESS - CASING TO BE JACKED WITH NO SOIL REMOVAL AHEAD OF PIPE
SEALS:	BOTH ENDS YES PERMEABLE GEOTEXTILE FABRIC

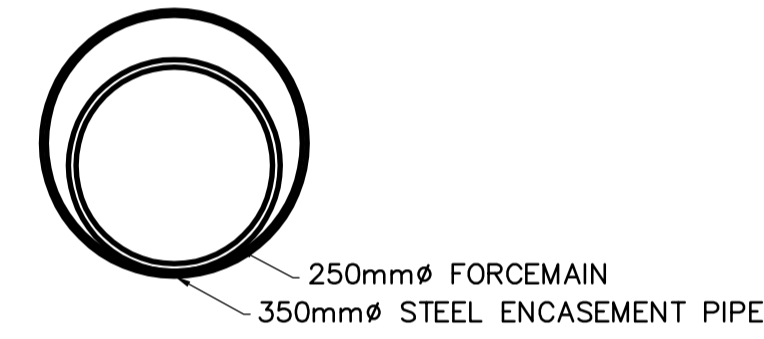

1 CASING PIPE DETAIL
WZ-C0101 NTS

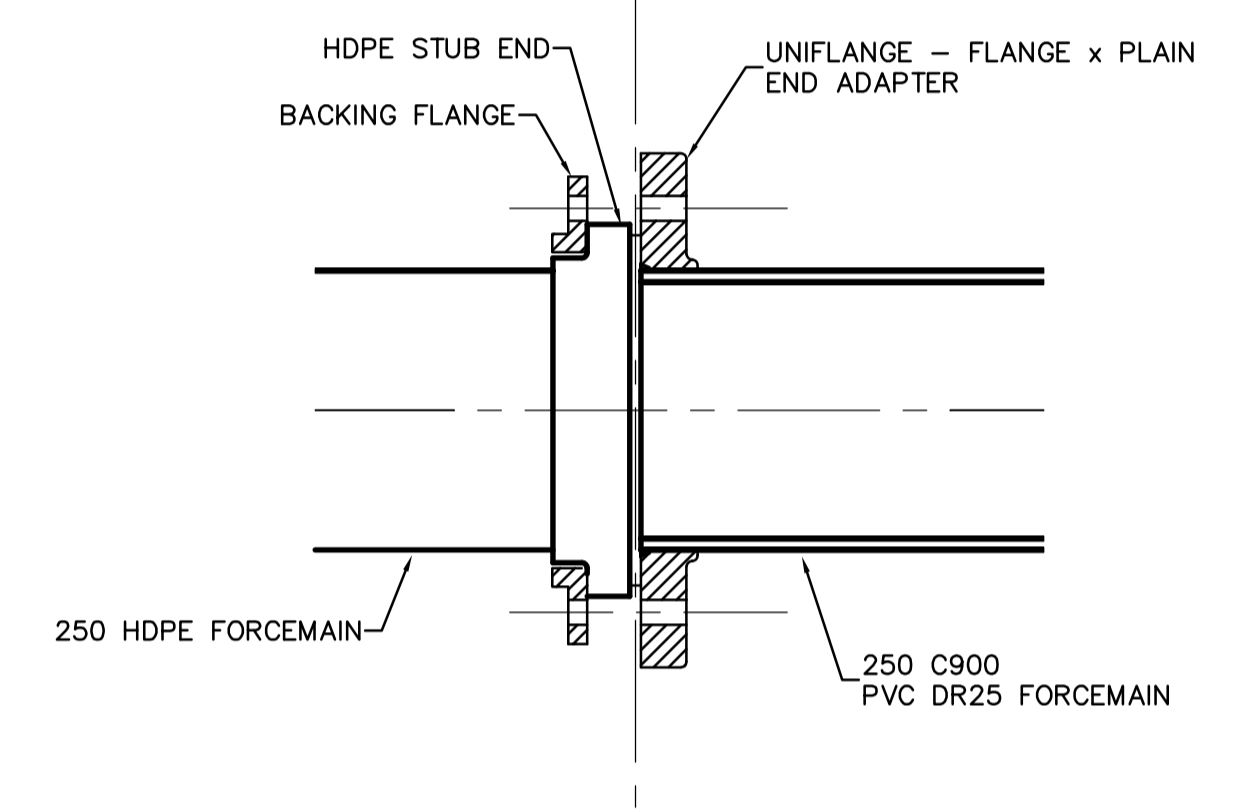

2 HDPE TO PVC CONNECTION
WZ-C0118 NTS

- GENERAL NOTES:**
- BASE LINE IS SOUTH LIMIT OF RIGHT OF WAY.
 - EXPOSE ALL COMMUNICATION AND POWER DUCTS/LINES BY HYDROVAC EXCAVATION.
 - VERIFY EXISTING PIPE INVERTS AND LOCATION PRIOR TO COMMENCEMENT OF WORKS.
 - EXPOSE AQUEDUCT AND CONFIRM ELEVATION BY VACUUM EXCAVATION PRIOR TO FORCEMAIN CONSTRUCTION. ENCASEMENT PIPE TO BE INSTALLED BY TRENCHLESS METHODS. EXCAVATION SHALL BE MIN. 5m FROM EITHER SIDE OF AQUEDUCT AND SHORED TO PREVENT MOVEMENT OF GROUND UNDER AND AROUND AQUEDUCT.
 - BACKFILL IN OPEN CUT TRENCHES SHALL BE CLASS 4 BACKFILL WITH CLASS B BEDDING. BACKFILL UNDER OR WITHIN 1.0m OF ROADWAY SHALL BE CLASS 2 BACKFILL WITH CLASS B BEDDING EXCEPT AS NOTED.

BENCHMARK NOTES:
DRAWING COORDINATES ARE UTM NAD83 - SCALE FACTOR 0.99983

B.M. No.	NORTHING	EASTING	ELEVATION
PILE 136	5523873.734	647764.406	236.242
PILE 133	5523256.606	647782.387	236.056

NOTE:
A. LOCATION OF UNDERGROUND STRUCTURES AS SHOWN ARE BASED ON THE BEST INFORMATION AVAILABLE. BUT NO GUARANTEE IS GIVEN THAT ALL EXISTING UTILITIES ARE SHOWN OR THAT THE GIVEN LOCATIONS ARE EXACT. CONFIRMATION OF EXISTENCE AND EXACT LOCATION OF ALL SERVICES MUST BE OBTAINED FROM THE INDIVIDUAL UTILITIES BEFORE PROCEEDING WITH CONSTRUCTION.



150 mm W.M.	WATERMAIN	150 mm W.M.	HYDRO	HYDRO	ANCHOR	ANCHOR
300mm L.D.S.	LAND DRAINAGE SEWER	300mm L.D.S.	CONCRETE	ASPHALT	POLE	POLE
250mm W.W.S.	WASTEWATER SEWER	250mm W.W.S.	PROPERTY LINE	SURVEY BAR	RAIL X-ING SIGNAL	RAIL X-ING SIGNAL
	MANHOLE		ELEVATION	TREE	DITCH	DITCH
	CATCH BASIN		ANODE	CONCRETE SIDEWALK		
	CURB INLET		FENCE			
	JUNCTIONS					
	CULVERT					
	GAS					
EXISTING	LEGEND - PLAN	PROPOSED	EXISTING	LEGEND - PLAN	PROPOSED	EXISTING

LOCATION APPROVED UNDERGROUND STRUCTURES

SUPV. U/G STRUCTURES COMMITTEE DATE

NOTE:
LOCATION OF UNDERGROUND STRUCTURES AS SHOWN ARE BASED ON THE BEST INFORMATION AVAILABLE. BUT NO GUARANTEE IS GIVEN THAT ALL EXISTING UTILITIES ARE SHOWN OR THAT THE GIVEN LOCATIONS ARE EXACT. CONFIRMATION OF EXISTENCE AND EXACT LOCATION OF ALL SERVICES MUST BE OBTAINED FROM THE INDIVIDUAL UTILITIES BEFORE PROCEEDING WITH CONSTRUCTION.

B.M. ELEV.	NO.	REVISIONS	DATE	BY
	00	ISSUED FOR TENDER	07/07/30	DA

CH2MHILL
Frederickson Cooper ARCHITECTS

EarthTech
A Tyco International Ltd. Company

DESIGNED BY: KWF
DRAWN BY: MAF
SCALE: HORZ. 1:500
VERT. 1:50

CHECKED BY: GK
APPROVED BY: AHL
RELEASED FOR CONSTRUCTION BY: R. SOROKOWSKI

DATE: 2005/12/09
DATE: 2007/7/30

ENGINEER'S SEAL

PROVINCE OF MANITOBA
ORIGINAL SIGNED BY
K.W. FITCHETT
30/07/2007
REGISTERED PROFESSIONAL ENGINEER

CONSULTANT DRAWING NO.
WZ-C0118

THE CITY OF WINNIPEG
WATER AND WASTE DEPARTMENT
ENGINEERING DIVISION

WATER TREATMENT PLANT
SUPPLY AND INSTALLATION
OF FORCEMAIN

CIVIL
GWWD AQUEDUCT R.O.W.
STA. 27+40 TO STA. 29+10

CITY FILE NUMBER
SHEET 19 OF 23
CITY DRAWING NUMBER
1-0601Z-C-C0118-001-00D