



THE CITY OF WINNIPEG

BID OPPORTUNITY

BID OPPORTUNITY NO. 527-2008

**SUPPLY AND DELIVERY OF MEN'S AND WOMEN'S BUS OPERATOR UNIFORM
PANTS AND SHORTS**

TABLE OF CONTENTS

PART A - BID SUBMISSION

Form A: Bid	1
Form B: Prices	3
Form U: Union Shop Confirmation	5

PART B - BIDDING PROCEDURES

B1. Contract Title	1
B2. Submission Deadline	1
B3. Enquiries	1
B4. Addenda	1
B5. Substitutes	2
B6. Bid Submission	2
B7. Bid	3
B8. Prices	4
B9. Qualification	4
B10. Opening of Bids and Release of Information	5
B11. Irrevocable Bid	5
B12. Withdrawal of Bids	6
B13. Evaluation of Bids	6
B14. Award of Contract	6

PART C - GENERAL CONDITIONS

C0. General Conditions	1
------------------------	---

PART D - SUPPLEMENTAL CONDITIONS

General

D1. General Conditions	1
D2. Unfair Labour Practices	1
D3. Scope of Work	1
D4. Contract Administrator	1
D5. Notices	1

Submissions

D6. Authority to Carry on Business	1
------------------------------------	---

Schedule of Work

D7. Commencement	2
D8. Delivery	2

Measurement and Payment

D9. Payment	2
-------------	---

Indemnity

D10. Indemnity	2
----------------	---

Warranty

D11. Warranty	2
---------------	---

PART E - SPECIFICATIONS

General

E1. Applicable Specifications	1
E2. Goods	1
E3. Bus Operator Uniform Pants – Men's	1
E4. Bus Operator Uniform Pants – Women's	3
E5. Bus Operator Uniform Pleated Shorts – Men's	6
E6. Bus Operator Uniform Pleated Shorts – Women's	8

PART B - BIDDING PROCEDURES

B1. CONTRACT TITLE

B1.1 SUPPLY AND DELIVERY OF MEN'S AND WOMEN'S BUS OPERATOR UNIFORM PANTS AND SHORTS

B2. SUBMISSION DEADLINE

B2.1 The Submission Deadline is 4:00 p.m. Winnipeg time, July 18, 2008.

B2.2 Bids determined by the Manager of Materials to have been received later than the Submission Deadline will not be accepted and will be returned upon request.

B2.3 The Contract Administrator or the Manager of Materials may extend the Submission Deadline by issuing an addendum at any time prior to the time and date specified in B2.1.

B3. ENQUIRIES

B3.1 All enquiries shall be directed to the Contract Administrator identified in D4.1.

B3.2 If the Bidder finds errors, discrepancies or omissions in the Bid Opportunity, or is unsure of the meaning or intent of any provision therein, the Bidder shall promptly notify the Contract Administrator of the error, discrepancy or omission at least five (5) Business Days prior to the Submission Deadline.

B3.3 If the Bidder is unsure of the meaning or intent of any provision therein, the Bidder should request clarification as to the meaning or intent prior to the Submission Deadline.

B3.4 Responses to enquiries which, in the sole judgment of the Contract Administrator, require a correction to or a clarification of the Bid Opportunity will be provided by the Contract Administrator to all Bidders by issuing an addendum.

B3.5 Responses to enquiries which, in the sole judgment of the Contract Administrator, do not require a correction to or a clarification of the Bid Opportunity will be provided by the Contract Administrator only to the Bidder who made the enquiry.

B3.6 The Bidder shall not be entitled to rely on any response or interpretation received pursuant to B3 unless that response or interpretation is provided by the Contract Administrator in writing.

B4. ADDENDA

B4.1 The Contract Administrator may, at any time prior to the Submission deadline, issue addenda correcting errors, discrepancies or omissions in the Bid Opportunity, or clarifying the meaning or intent of any provision therein.

B4.2 The Contract Administrator will issue each addendum at least two (2) Business Days prior to the Submission Deadline, or provide at least two (2) Business Days by extending the Submission Deadline.

B4.2.1 Addenda will be available on the Bid Opportunities page at The City of Winnipeg, Corporate Finance, Materials Management Division internet site at <http://www.winnipeg.ca/matmgt>

B4.2.2 The Bidder is responsible for ensuring that he has received all addenda and is advised to check the Materials Management Division internet site for addenda regularly and shortly before the Submission Deadline, as may be amended by addendum.

B4.3 The Bidder shall acknowledge receipt of each addendum in Paragraph 8 of Form A: Bid. Failure to acknowledge receipt of an addendum may render a Bid non-responsive.

B5. SUBSTITUTES

- B5.1 The Work is based on the materials, equipment, methods and products specified in the Bid Opportunity.
- B5.2 Substitutions shall not be allowed unless application has been made to and prior approval has been granted by the Contract Administrator in writing.
- B5.3 Requests for approval of a substitute will not be considered unless received in writing by the Contract Administrator at least seven (7) Business Days prior to the Submission Deadline.
- B5.4 The Bidder shall ensure that any and all requests for approval of a substitute:
- (a) provide sufficient information and details to enable the Contract Administrator to determine the acceptability of the material, equipment, method or product as either an approved equal or alternative;
 - (b) identify any and all changes required in the applicable Work, and all changes to any other Work, which would become necessary to accommodate the substitute;
 - (c) identify any anticipated cost or time savings that may be associated with the substitute;
 - (d) certify that, in the case of a request for approval as an approved equal, the substitute will fully perform the functions called for by the general design, be of equal or superior substance to that specified, is suited to the same use and capable of performing the same function as that specified and can be incorporated into the Work, strictly in accordance with the Contract;
 - (e) certify that, in the case of a request for approval as an approved alternative, the substitute will adequately perform the functions called for by the general design, be similar in substance to that specified, is suited to the same use and capable of performing the same function as that specified and can be incorporated into the Work, strictly in accordance with the Contract.
- B5.5 The Contract Administrator, after assessing the request for approval of a substitute, may in his sole discretion grant approval for the use of a substitute as an “approved equal” or as an “approved alternative”, or may refuse to grant approval of the substitute.
- B5.6 The Contract Administrator will provide a response in writing, at least two (2) Business Days prior to the Submission Deadline, only to the Bidder who requested approval of the substitute.
- B5.6.1 The Bidder requesting and obtaining the approval of a substitute shall be entirely responsible for disseminating information regarding the approval to any person or persons he wishes to inform.
- B5.7 If the Contract Administrator approves a substitute as an “approved equal”, any Bidder may use the approved equal in place of the specified item.
- B5.8 If the Contract Administrator approves a substitute as an “approved alternative”, any Bidder bidding that approved alternative may base his Total Bid Price upon the specified item but may also indicate an alternative price based upon the approved alternative. Such alternatives will be evaluated in accordance with B13.
- B5.9 No later claim by the Contractor for an addition to the price(s) because of any other changes in the Work necessitated by the use of an approved equal or an approved alternative will be considered.

B6. BID SUBMISSION

- B6.1 The Bid shall consist of the following components:
- (a) Form A: Bid;
 - (b) Form B: Prices;

(c) Form U: Union Shop Confirmation.

- B6.2 Further to B6.1, the Bidder should include the written correspondence from the Contract Administrator approving a substitute in accordance with B5.
- B6.3 All components of the Bid shall be fully completed or provided, and submitted by the Bidder no later than the Submission Deadline, with all required entries made clearly and completely in ink, to constitute a responsive Bid.
- B6.4 The Bid Submission may be submitted by mail, courier or personal delivery, or by facsimile transmission.
- B6.5 If the Bid Submission is submitted by mail, courier or personal delivery, it shall be enclosed and sealed in an envelope clearly marked with the Bid Opportunity number and the Bidder's name and address, and shall be submitted to:
- The City of Winnipeg
Corporate Finance Department
Materials Management Division
185 King Street, Main Floor
Winnipeg MB R3B 1J1
- B6.5.1 Samples or other components of the Bid Submission which cannot reasonably be enclosed in the envelope may be packaged separately, but shall be clearly marked with the Bid Opportunity number, the Bidder's name and address, and an indication that the contents are part of the Bidder's Bid Submission.
- B6.6 Bidders are advised not to include any information/literature except as requested in accordance with B6.1.
- B6.7 Bidders are advised that inclusion of terms and conditions inconsistent with the Bid Opportunity document, including the General Conditions, may result in the Bid being determined to be non-responsive.
- B6.8 If the Bid Submission is submitted by facsimile transmission, it shall be submitted to (204) 949-1178.
- B6.8.1 The Bidder is advised that the City cannot take responsibility for the availability of the facsimile machine at any time.
- B6.9 Bids submitted by internet electronic mail (e-mail) will not be accepted.
- B7. BID**
- B7.1 The Bidder shall complete Form A: Bid, making all required entries.
- B7.2 Paragraph 2 of Form A: Bid shall be completed in accordance with the following requirements:
- (a) if the Bidder is a sole proprietor carrying on business in his own name, his name shall be inserted;
 - (b) if the Bidder is a partnership, the full name of the partnership shall be inserted;
 - (c) if the Bidder is a corporation, the full name of the corporation shall be inserted;
 - (d) if the Bidder is carrying on business under a name other than his own, the business name and the name of every partner or corporation who is the owner of such business name shall be inserted.
- B7.2.1 If a Bid is submitted jointly by two or more persons, each and all such persons shall identify themselves in accordance with B7.2.
- B7.3 In Paragraph 3 of Form A: Bid, the Bidder shall identify a contact person who is authorized to represent the Bidder for purposes of the Bid.

- B7.4 Paragraph 10 of Form A: Bid shall be signed in accordance with the following requirements:
- (a) if the Bidder is a sole proprietor carrying on business in his own name, it shall be signed by the Bidder;
 - (b) if the Bidder is a partnership, it shall be signed by the partner or partners who have authority to sign for the partnership;
 - (c) if the Bidder is a corporation, it shall be signed by its duly authorized officer or officers;
 - (d) if the Bidder is carrying on business under a name other than his own, it shall be signed by the registered owner of the business name, or by the registered owner's authorized officials if the owner is a partnership or a corporation.
- B7.4.1 The name and official capacity of all individuals signing Form A: Bid should be printed below such signatures.
- B7.4.2 All signatures shall be original.
- B7.5 If a Bid is submitted jointly by two or more persons, the word "Bidder" shall mean each and all such persons, and the undertakings, covenants and obligations of such joint Bidders in the Bid and the Contract, when awarded, shall be both joint and several.

B8. PRICES

- B8.1 The Bidder shall state a price in Canadian funds for each item of the Work identified on Form B: Prices.
- B8.1.1 Prices on Form B: Prices shall include:
- (a) duty;
 - (b) freight and cartage;
 - (c) Provincial and Federal taxes [except the Goods and Services Tax (GST) and Manitoba Retail Sales Tax (MRST, also known as PST), which shall be extra where applicable] and all charges governmental or otherwise paid;
 - (d) profit and all compensation which shall be due to the Contractor for the Work and all risks and contingencies connected therewith.
- B8.2 The quantities listed on Form B: Prices are to be considered approximate only. The City will use said quantities for the purpose of comparing Bids.
- B8.3 The quantities for which payment will be made to the Contractor are to be determined by the Work actually performed and completed by the Contractor, to be measured as specified in the applicable Specifications.
- B8.4 Prices from Non-Resident Bidders are subject to a Non-Resident Withholding Tax pursuant to the Income Tax Act (Canada).

B9. QUALIFICATION

- B9.1 The Bidder shall:
- (a) undertake to be in good standing under The Corporations Act (Manitoba), or properly registered under The Business Names Registration Act (Manitoba), or otherwise properly registered, licensed or permitted by law to carry on business in Manitoba, or if the Bidder does not carry on business in Manitoba, in the jurisdiction where the Bidder does carry on business; and
 - (b) be financially capable of carrying out the terms of the Contract; and
 - (c) have all the necessary experience, capital, organization, and equipment to perform the Work in strict accordance with the terms and provisions of the Contract.

- B9.2 The Bidder and any proposed Subcontractor (for the portion of the Work proposed to be subcontracted to them) shall:
- (a) be responsible and not be suspended, debarred or in default of any obligations to the City a list of suspended or debarred individuals and companies is available on the Information Connection page at The City of Winnipeg, Corporate Finance, Materials Management Division internet site at <http://www.winnipeg.ca/matmgt/debar.stm> .
- B9.3 The Bidder and/or any proposed Subcontractor (for the portion of the Work proposed to be subcontracted to them) shall:
- (a) have successfully carried out work similar in nature, scope and value to the Work; and
 - (b) be fully capable of performing the Work required to be in strict accordance with the terms and provisions of the Contract; and
 - (c) have a written workplace safety and health program, if required, pursuant to The Workplace Safety and Health Act (Manitoba);
 - (d) goods shall be manufactured in a Union.
- B9.4 The Bidder shall submit, within three (3) Business Days of a request by the Contract Administrator, proof satisfactory to the Contract Administrator of the qualifications of the Bidder and of any proposed Subcontractor.
- B9.5 The Bidder shall provide, on the request of the Contract Administrator, full access to any of the Bidder's equipment and facilities to confirm, to the Contract Administrator's satisfaction, that the Bidder's equipment and facilities are adequate to perform the Work.
- B9.6 Union Shop Confirmation
- (a) The Bidder shall complete Form U, Union Shop Confirmation confirming Union requirements to demonstrate the Bidders qualifications to undertake the Work.

B10. OPENING OF BIDS AND RELEASE OF INFORMATION

- B10.1 Bids will not be opened publicly.
- B10.2 Following the Submission Deadline, the names of the Bidders and their bid prices (unevaluated, and pending review and verification of conformance with requirements or evaluated prices) will be available on the Closed Bid Opportunities (or Public/Posted Opening & Award Results) page at The City of Winnipeg, Corporate Finance, Materials Management Division internet site at <http://www.winnipeg.ca/matmgt>
- B10.3 After award of Contract, the name(s) of the successful Bidder(s) and the Contract Amount(s) will be available on the Closed Bid Opportunities (or Public/Posted Opening & Award Results) page at The City of Winnipeg, Corporate Finance, Materials Management Division internet site at <http://www.winnipeg.ca/matmgt>
- B10.4 The Bidder is advised that any information contained in any Bid may be released if required by City policy or procedures, by The Freedom of Information and Protection of Privacy Act (Manitoba), by other authorities having jurisdiction, or by law.

B11. IRREVOCABLE BID

- B11.1 The Bid(s) submitted by the Bidder shall be irrevocable for the time period specified in Paragraph 9 of Form A: Bid.
- B11.2 The acceptance by the City of any Bid shall not release the Bids of the next two lowest evaluated responsive Bidders and these Bidders shall be bound by their Bids on such Work for the time period specified in Paragraph 9 of Form A: Bid.

B12. WITHDRAWAL OF BIDS

- B12.1 A Bidder may withdraw his Bid without penalty by giving written notice to the Manager of Materials at any time prior to the Submission Deadline.
- B12.1.1 Notwithstanding C21, the time and date of receipt of any notice withdrawing a Bid shall be the time and date of receipt as determined by the Manager of Materials.
- B12.1.2 The City will assume that any one of the contact persons named in Paragraph 3 of Form A: Bid or the Bidder's authorized representatives named in Paragraph 10 of Form A: Bid, and only such person, has authority to give notice of withdrawal.
- B12.1.3 If a Bidder gives notice of withdrawal prior to the Submission Deadline, the Manager of Materials will:
- (a) retain the Bid until after the Submission Deadline has elapsed;
 - (b) open the Bid to identify the contact person named in Paragraph 3 of Form A: Bid and the Bidder's authorized representatives named in Paragraph 10 of Form A: Bid; and
 - (c) if the notice has been given by any one of the persons specified in B12.1.3(b), declare the Bid withdrawn.
- B12.2 A Bidder who withdraws his Bid after the Submission Deadline but before his Bid has been released or has lapsed as provided for in B11.2 shall be liable for such damages as are imposed upon the Bidder by law and subject to such sanctions as the Chief Administrative Officer considers appropriate in the circumstances. The City, in such event, shall be entitled to all rights and remedies available to it at law.

B13. EVALUATION OF BIDS

- B13.1 Award of the Contract shall be based on the following bid evaluation criteria:
- (a) compliance by the Bidder with the requirements of the Bid Opportunity (pass/fail);
 - (b) qualifications of the Bidder and the Subcontractors, if any, pursuant to B9 (pass/fail);
 - (c) Total Bid Price;
 - (d) economic analysis of any approved alternative pursuant to B5;
 - (e) costs to the City of administering multiple contracts.
- B13.2 Further to B13.1(a), the Award Authority may reject a Bid as being non-responsive if the Bid Submission is incomplete, obscure or conditional, or contains additions, deletions, alterations or other irregularities. The Award Authority may reject all or any part of any Bid, or waive technical requirements or minor informalities or irregularities if the interests of the City so require.
- (a) The Bidder shall, within seven (7) Calendar Days of a request by the Contract Administrator, provide representative samples of the goods offered.
- B13.3 Further to B13.1(b), the Award Authority shall reject any Bid submitted by a Bidder who does not demonstrate, in his Bid or in other information required to be submitted, that he is responsible and qualified.
- B13.4 Further to B13.1(c), the Total Bid Price shall be the sum of the quantities multiplied by the unit prices for each item shown on Form B: Prices.
- B13.5 This Contract will be awarded as a whole.

B14. AWARD OF CONTRACT

- B14.1 The City will give notice of the award of the Contract or will give notice that no award will be made.

- B14.2 The City will have no obligation to award a Contract to a Bidder, even though one or all of the Bidders are determined to be responsible and qualified, and the Bids are determined to be responsive.
- B14.2.1 Without limiting the generality of B14.2, the City will have no obligation to award a Contract where:
- (a) the prices exceed the available City funds for the Work;
 - (b) the prices are materially in excess of the prices received for similar work in the past;
 - (c) the prices are materially in excess of the City's cost to perform the Work, or a significant portion thereof, with its own forces;
 - (d) only one Bid is received; or
 - (e) in the judgment of the Award Authority, the interests of the City would best be served by not awarding a Contract.
- B14.3 Where an award of Contract is made by the City, the award shall be made to the responsible and qualified Bidder submitting the lowest evaluated responsive Bid, in accordance with B13.
- B14.3.1 Following the award of contract, a Bidder will be provided with information related to the evaluation of his Bid upon written request to the Contract Administrator.
- B14.4 Notwithstanding C4 and Paragraph 6, the City will issue a Purchase Order to the successful Bidder in lieu of the execution of a Contract.
- B14.5 The Contract Documents, as defined in C1.1(n) (ii) in their entirety shall be deemed to be incorporated in and to form a part of the Purchase Order notwithstanding that they are not necessarily attached to or accompany said Purchase Order.

PART C - GENERAL CONDITIONS

C0. GENERAL CONDITIONS

- C0.1 The *General Conditions for the Supply and Delivery of Goods* (Revision 2008 05 26) are applicable to the Work of the Contract.
- C0.1.1 The *General Conditions for the Supply and Delivery of Goods* are available on the Information Connection page at The City of Winnipeg, Corporate Finance, Materials Management Division internet site at http://www.winnipeg.ca/matmgt/gen_cond.stm
- C0.2 A reference in the Bid Opportunity to a section, clause or subclause with the prefix “**C**” designates a section, clause or subclause in the *General Conditions for Supply of Goods*.

PART D - SUPPLEMENTAL CONDITIONS

GENERAL

D1. GENERAL CONDITIONS

D1.1 In addition to the *General Conditions for the Supply and Delivery of Goods*, these Supplemental Conditions are applicable to the Work of the Contract.

D2. UNFAIR LABOUR PRACTICES

D2.1 Further to GC2.02, the Contractor declares that in bidding for the work and in entering into this contract, he and his subcontractors conduct their respective business in accordance with established international codes as they relate to child and forced labour embodied in United Nations (UN) and International Labour Organization (ILO) conventions as ratified by Canada.

D2.2 The Contractor shall forfeit all claims under the Contract as well as refund to the City any monies paid to him, beyond his actual proven expenses for work done, if this declaration is shown to be false.

D3. SCOPE OF WORK

D3.1 The Work to be done under the Contract shall consist of supply and delivery of men's and women's bus operator pants and shorts.

D4. CONTRACT ADMINISTRATOR

D4.1 The Contract Administrator is:
John Derksen
Supervisor of Stores
Winnipeg Transit Department
421 Osborne Street
Winnipeg, Manitoba R3L 2A2
Telephone No. (204) 986-5811
Facsimile No. (204) 986-5809

D5. NOTICES

D5.1 Notwithstanding C21.3, all notices of appeal to the Chief Administrative Officer shall be sent to the attention of the Chief Financial Officer at the following address or facsimile number:

The City of Winnipeg
Chief Financial Officer
Administration Building, 3rd Floor
510 Main Street
Winnipeg MB R3B 1B9
Facsimile No.: (204) 949-1174

SUBMISSIONS

D6. AUTHORITY TO CARRY ON BUSINESS

D6.1 The Contractor shall be in good standing under The Corporations Act (Manitoba), or properly registered under The Business Names Registration Act (Manitoba), or otherwise properly registered, licensed or permitted by law to carry on business in Manitoba, or if the Contractor does not carry on business in Manitoba, in the jurisdiction where the Contractor does carry on

business, throughout the term of the Contract, and shall provide the Contract Administrator with evidence thereof upon request.

SCHEDULE OF WORK

D7. COMMENCEMENT

D7.1 The Contractor shall not commence any Work until he is in receipt of a notice of award from the City authorizing the commencement of the Work.

D7.2 The Contractor shall not commence any Work until:

(a) the Contract Administrator has confirmed receipt and approval of:

(i) evidence of authority to carry on business specified in D6.

(b) the Contractor has attended a meeting with the Contract Administrator, or the Contract Administrator has waived the requirement for a meeting.

D8. DELIVERY

D8.1 Goods shall be delivered on or before October 17, 2008, f.o.b. destination, freight prepaid to:

John Derksen
Transit Stores
421 Osborne Street
Winnipeg, Manitoba
R3L 2A2

D8.2 The Contractor shall confirm the delivery with the Contract Administrator or his/her designate, at least two (2) Business Days before delivery.

D8.3 The Contractor shall off-load goods as directed at the delivery location.

MEASUREMENT AND PAYMENT

D9. PAYMENT

D9.1 Further to C10, the City may at its option pay the Contractor by direct deposit to the Contractor's banking institution.

INDEMNITY

D10. INDEMNITY

D10.1 Further to C15, the Contractor shall indemnify the City in the amount of the Contract value.

WARRANTY

D11. WARRANTY

D11.1 Warranty is as stated in C11.

PART E - SPECIFICATIONS

GENERAL

E1. APPLICABLE SPECIFICATIONS

- E1.1 These Specifications shall apply to the Work.
- E1.2 Bidders are reminded that requests for approval of substitutes as an approved equal or an approved alternative shall be made in accordance with B5.

E2. GOODS

- E2.1 The Contractor shall supply men's and women's bus operator uniform pants and shorts in accordance with the requirements hereinafter specified.

E3. BUS OPERATOR UNIFORM PANTS – MEN'S

- E3.1 This specification shall govern the manufacture and inspection of Men's Western Style Pants.
- E3.2 The Men's Western Style Pants shall be designed according to the attached pattern and the attached drawings, forming part of this specification, and shall conform in every respect to the sample, except as noted in the specifications.
- E3.3 Size and Dimensions – Men's Western Style Pants to this specification shall be supplied in the sizes specified by the City. Measurements, drawings, and pattern attached in this specification are for a size 34 Men's Pant. Manufacture to standard 2" graded waist sizes 28"-58".

Materials

- E3.4 Care requirements shall be consistent with all the components of the finished garment. The Men's Western Style Pants shall be machine washable and dryable.
- E3.5 Outer Fabric - From Victor
 - (a) Fiber: 54% Polyester 44% Wool 2% Lycra;
 - (b) Weave: plain;
 - (c) Weight: 10-11 oz/lin yd;
 - (d) 62 ends per inch;
 - (e) 50 picks per inch;
 - (f) Color: WT20013/3 Transit Blue;
 - (g) Care: machine washable cold, Gentle Cycle, tumble dry-low.
- E3.6 Pocketing
 - (a) Fiber: commercial quality, perma press pocketing, Dominion Textile Beaujean A9086 or equivalent must be used,
 - (b) Colour: natural or pale blue,;
 - (c) Care: washable and tumble dry.
- E3.7 Notions
 - (a) Zipper: YKK #5cm, metal zipper, colour to match outer fabric
 - (b) Hook and bar closure: rust proof, black, good commercial quality;
 - (c) Thread: spun polyester, size 40 colour to match fabric.

Construction

- E3.8 Pants are to be factory permanent pressed along front and back creaselines.
- E3.9 Regulation civilian style, easy over hip and cut to allow comfort when in the seated position.
- E3.10 Seams:
- (a) All seam allowances, at least 3/8" wide, shall be serged, seamed and pressed open. Stitches shall present a regular even appearance without puckers;
 - (b) There shall be not less than 3 nor more than 4 stitches per cm;
 - (c) The specified thread shall be used;
 - (d) Seat seams to be sewed with flat stitch machine;
 - (e) Allow 5cm outlets in seams for any necessary alterations;
 - (f) Crotch pieces to be lined same as fly or equivalent.
- E3.11 Front Zipper:
- (a) Fly front must be lined and have a French bearer;
 - (b) Stitching at the waistband seam and fly front to be deluxe AA@ thread not less than 12 stitches to the inch;
 - (c) Bar tacked at lower edge.
- E3.12 Waistband:
- (a) Snugtex waistband. Washable and tumble dry. 4cm wide. See drawing;
 - (b) Closure at fly with hook and bar closure and button safety closure on fly lining;
 - (c) Waistband should fold back upon itself at the center front, the width of the fly, to provide a solid base for hook and bar closure.
- E3.13 Hems:
- (a) Lower edge of pants are to be serged and left unhemmed;
 - (b) Side leg length 122cm for regular sizes, waist seam to lower unfinished edge of garment;
 - (c) Leg width at lower hem = 23cm for size 34.
- E3.14 Belt Loops:
- (a) Seven loops are to be made of self fabric, not less than 12mm wide, nor more than 16mm wide;
 - (b) Loops must be sewn into waistband seam;
 - (c) They must accommodate a belt of at least 4cm wide.
 - (d) Center back belt loop is necessary.
- E3.15 Front Pockets:
- (a) Western pocket design;
 - (b) Front pockets are to have an opening of at least 15cm , but not more than 18cm.;
 - (c) The lining must allow a pocket length of at least 28cm, from waist seam;
 - (d) Bar tacking at stress points.
- E3.16 Change pocket:
- (a) Above right pocket opening. 7cm opening, depth of 9cm.;
 - (b) Bar tacked at stress points.
- E3.17 Back pockets:

- (a) Conventional two hip pockets with standard single or double welt shall be placed 7cm below back waist and be 14cm in length;
- (b) Left hip pocket to have diamond shaped tab to button and to measure 2 inches by 1 3 inch;
- (c) All pockets securely bar tacked at ends. Illustration MP2.

E3.18 Marking:

- (a) Each pair of pants shall have a durable label sewn on to the inside pant on the left front pocket lining. It shall contain the following information:
 - (i) manufacturer's identification;
 - (ii) date of manufacture;
 - (iii) size code.

E3.19 Care Instructions:

- (a) Each pair of pants shall have a durable label sewn into the inside pant on the left front pocket lining detailing care requirements consistent with all components of the finished garment.
- (b) Men's Western Style Pants shall be machine washable and dryable.
- (c) Hang Tags available from the manufacturers of the garment=s components, describing the characteristics and care of the Teflon coating and fabric shall be attached to each garment.

E3.20 Pressing:

- (a) All seams shall be properly pressed and the finished garment shall be pressed to the best commercial standards.

E3.21 Union Label:

- (a) The Contractor shall be a Union Shop and each pair of pants shall bear a union label affixed to the inside body of the finished garment.

E3.22 Packaging:

- (a) Pants shall be packaged in boxes containing one size only with the size clearly shown on the outside of the box.

E4. BUS OPERATOR UNIFORM PANTS – WOMEN'S

E4.1 This specification shall govern the manufacture and inspection of Women's Western Style Pants.

E4.2 The Women's Western Style Pants shall be designed according to the attached pattern and the attached drawings, forming part of this specification, and shall conform in every respect to the sample, except as noted in the specifications.

E4.3 Size and Dimensions – Women's Western Style Pants to this specification shall be supplied in the sizes specified by the City. Measurements, drawings, and pattern attached in this specification are for a size 12 Women's Pant. Manufacture to standard 2" graded hip sizes 6-30. Size 12 = 30-32" waist / 39-41" hip.

Materials

E4.4 Care requirements shall be consistent with all the components of the finished garment. The Women's Western Style Pants shall be machine washable and dryable.

E4.5 Outer Fabric - From Victor

- (a) Fiber: 54% Polyester 44% Wool 2% Lycra;
- (b) Weave: plain;

- (c) Weight: 10-11 oz/lin yd;
- (d) 62 ends per inch;
- (e) 50 picks per inch;
- (f) Colour: WT20013/3 Transit Blue;
- (g) Care: machine washable cold, gentle cycle, tumble dry – low.

E4.6 Pocketing

- (a) Fiber: commercial quality, perma press pocketing, Dominion Textile Beaujean A9086 or equivalent must be used;
- (b) Colour: natural or pale blue;
- (c) Care: washable and tumble dry.

E4.7 Notions

- (a) Zipper: YKK #5cm, metal zipper, colour to match outer fabric;
- (b) Hook and bar closure: rust proof, black, good commercial quality;
- (c) Thread: spun polyester, size 40 colour to match fabric.

Construction:

E4.8 Pants are to be factory permanent pressed along front and back creaselines.

E4.9 Regulation civilian style, easy over hip and cut to allow comfort when in the seated position.

E4.10 Seams:

- (a) All seam allowances, at least 3/8" wide, shall be serged, seamed and pressed open;
- (b) Stitches shall present a regular even appearance without puckers;
- (c) There shall be not less than 3 or more than 4 stitches per cm.;
- (d) The specified thread shall be used;
- (e) Seat seams to be sewed with flat stitch machine;
- (f) Allow 5cm outlets in seams for any necessary alterations.

E4.11 Front Zipper:

- (a) Right fly front closure stitching 3cm from front edge;
- (b) Bar tacked at lower edge;
- (c) Stitch at waistband seam and fly front to be deluxe "A" thread not less than 12 stitches to the inch.

E4.12 Waistband: Snugtex waistband.

- (a) Washable and tumble dry, 4cm wide;
- (b) Centre back waist differs from sample. See drawing.
- (c) Closure at fly with hook and bar closure and button safety closure on fly lining.
- (d) Waistband should fold back upon itself at the centre front, the width of the fly, to provide a solid base for hook and bar closure.

E4.13 Hems:

- (a) Lower edge of pants are to be serged and left unhemmed;
- (b) Side leg length 111cm for regular sizes, waist seam to lower unfinished edge of garment;
- (c) Leg width at lower hem = 23cm for size 12.

- E4.14 Belt Loops:
- (a) Seven loops are to be made of self fabric, not less than 12mm wide, nor more than 16mm wide;
 - (b) Loops must be sewn into waistband seam;
 - (c) They must accommodate a belt of at least 4cm wide;
 - (d) Center back belt loop is necessary.
- E4.15 Front Pockets:
- (a) Western pocket design;
 - (b) Front pockets are to have an opening of at least 15cm , but not more than 18cm.;
 - (c) The lining must allow a pocket length of at least 28cm, from waist seam;
 - (d) Front shaping darts are to be incorporated into the pocket design;
 - (e) Bar tacking at stress points.
- E4.16 Change pocket:
- (a) Above right pocket opening. 7cm opening, depth of 9cm.;
 - (b) Bar tacked at stress points.
- E4.17 Back Darts:
- (a) Two back darts help shape the pants;
 - (b) They are at least 12cm in length, but no more 15cm.;
 - (c) The waist dart overlap is to be one half of 36mm.
- E4.18 Marking:
- (a) Each pair of Women's Pants shall have a durable label sewn on to the inside pant on the left front pocket lining. It shall contain the following information:
 - (i) manufacturer's identification;
 - (ii) date of manufacture;
 - (iii) size code.
- E4.19 Care Instructions:
- (a) Each pair of pants shall have a durable label sewn into the inside pant on the left front pocket lining detailing care requirements consistent with all components of the finished garment.
 - (b) Women's Western Style Pants shall be machine washable and dryable.
 - (c) Hang Tags available from the manufacturers of the garment's components, describing the characteristics and care of the Teflon coating and fabric shall be attached to each garment.
- E4.20 Pressing:
- (a) All seams shall be properly pressed and the finished garment shall be pressed to the best commercial standards.
- E4.21 Union Label:
- (a) The Contractor shall be a Union Shop and each pair of pants shall bear a union label affixed to the inside body of the finished garment.
- E4.22 Packaging:
- (a) Pants shall be packaged in boxes containing one size only with the size clearly shown on the outside of the box.

E5. BUS OPERATOR UNIFORM PLEATED SHORTS – MEN'S

- E5.1 This specification shall govern the manufacture and inspection of Men's Pleated Shorts.
- E5.2 The Men's Pleated Shorts shall be designed according to the attached pattern and the attached drawings, forming part of this specification, and shall conform in every respect to the sample, except as noted in the specifications.
- E5.3 Size and Dimensions – Men's Pleated Shorts to this specification shall be supplied in the sizes specified by the City. Measurements, drawings, and pattern attached in this specification are for a size 34 Men's Shorts. Manufacture to standard 2" graded waist sizes 28"-58".

Materials:

- E5.4 Care requirements shall be consistent with all the components of the finished garment.
- E5.5 The Men's Pleated Shorts shall be machine washable and dryable.
- E5.6 Outer Fabric - From Victor
- (a) Fiber: 54 % Polyester, 44% Wool, 2% Lycra;
 - (b) Weave: plain;
 - (c) Weight: 10-11 oz/lin yd;
 - (d) 62 ends per inch;
 - (e) 50 picks per inch;
 - (f) Colour: WT20013/3 Transit Blue;
 - (g) Care: machine washable – cold, gentle cycle, tumble dry – low.
- E5.7 Pocketing
- (a) Fiber: commercial quality, perma press pocketing, Dominion Textile Beaujean A9086 or equivalent must be used;
 - (b) Colour: natural or pale blue;
 - (c) Care: washable and tumble dry.
- E5.8 Notions
- (a) Zipper: YKK #5cm, metal zipper, colour to match outer fabric;
 - (b) Hook and bar closure: rust proof, black, good commercial quality;
 - (c) Thread: spun polyester, size 40 colour to match fabric.

Construction:

- E5.9 Shorts are to be factory permanent pressed along front and back creaselines.
- E5.10 Style is a double pressed pleated dress short with slash pockets and elasticized side waist.
- E5.11 Cut to allow comfort when in the seated position.
- E5.12 Seams:
- (a) All seam allowances, at least 3/8" wide, shall be serged, seamed and pressed open;
 - (b) Stitches shall present a regular even appearance without puckers;
 - (c) There shall be not less than 3 nor more than 4 stitches per cm.;
 - (d) The specified thread shall be used. Seat seams to be sewed with flat stitch machine;
 - (e) Allow 5cm outlets in seams for any necessary alterations;
 - (f) Crotch pieces to be lined same as fly or equivalent.

- E5.13 Front Zipper:
- (a) Fly front must be lined and have a French bearer;
 - (b) Stitching at the waistband seam and fly front to be deluxe AA@ thread not less than 12 stitches to the inch;
 - (c) Bar tacked at lower edge.
- E5.14 Waistband:
- (a) Self fabric, interfaced. Finished at 4cm wide;
 - (b) Elastic is inserted at side waist between center of each side back and the front pleat, to allow for 3 extra inches of expansion at the waist. See drawing.
- E5.15 Closure at fly with hook and bar closure and button safety closure on fly lining.
- E5.16 Hems:
- (a) Lower edge of pants are to be serged and blindstitched with 4cm hem allowance;
 - (b) Side leg length 48cm for regular sizes, waist seam to lower finished edge of garment;
 - (c) Leg width at lower hem = 30cm for size 34.
- E5.17 Belt Loops:
- (a) Seven loops are to be made of self fabric, not less than 12mm wide, nor more than 16mm wide;
 - (b) Loops must be sewn into waistband seam;
 - (c) They must accommodate a belt of at least 4cm wide;
 - (d) Center back belt loop is necessary.
- E5.18 Front Pockets:
- (a) Slash pocket design;
 - (b) Front pockets are to have an opening of at least 17cm, but not more than 19cm.;
 - (c) The lining must allow a pocket length of at least 30cm, from waist seam;
 - (d) Bar tacking at stress points;
 - (e) The lining of the pocket shall extend to the center front of the shorts zipper placket, in such a manner that the pleats are supported underneath. See sample.
- E5.19 Back pockets:
- (a) Conventional right hip pocket with standard single or double welt shall be placed 7cm below back waist and be 14cm in length;
 - (b) To have diamond shaped tab to button and to measure 2 inches by 1 3 inch;
 - (c) All pockets securely bar tacked at ends. Illustration MP2.
- E5.20 Marking:
- (a) Each pair of Men's shorts shall have a durable label sewn on to the inside pant on the left front pocket lining. It shall contain the following information:
 - (i) manufacturer's identification;
 - (ii) date of manufacture;
 - (iii) size code.
- E5.21 Care Instructions:
- (a) Each pair of shorts have a durable label sewn into the inside pant on the left front pocket lining detailing care requirements consistent with all components of the finished garment;

(b) Men's Pleated Shorts shall be machine washable and dryable.

E5.22 Hang Tags available from the manufacturers of the garment's components, describing the characteristics and care of the Teflon coating and fabric shall be attached to each garment.

E5.23 Pressing:

(a) All seams shall be properly pressed and the finished garment shall be pressed to the best commercial standards.

E5.24 Union Label:

(a) The Contractor shall be a Union Shop and each pair of shorts shall bear a union label affixed to the inside body of the finished garment.

E5.25 Packaging:

(a) Shorts shall be packaged in boxes containing one size only with the size clearly shown on the outside of the box.

E6. BUS OPERATOR UNIFORM PLEATED SHORTS – WOMEN'S

E6.1 This specification shall govern the manufacture and inspection of Women's Pleated Shorts.

E6.2 The Women's Pleated Shorts shall be designed according to the attached pattern and the attached drawings, forming part of this specification, and shall conform in every respect to the sample, except as noted in the specifications.

E6.3 Size and Dimensions – Women's Pleated Shorts to this specification shall be supplied in the sizes specified by the City. Measurements, drawings, and pattern attached in this specification are for a size 12 Women's Shorts. Manufacture to standard 2" graded hip sizes 6-30. Size 12 = 30-32" waist / 39-41" hip.

Materials

E6.4 Care requirements shall be consistent with all the components of the finished garment. The Women's Pleated Shorts shall be machine washable and dryable.

E6.5 Outer Fabric - From Victor

- (a) Fiber: 54% Polyester 44% Wool 2% Lycra;
- (b) Weave: plain;
- (c) Weight: 10-11 oz/lin yd;
- (d) 62 ends per inch;
- (e) 50 picks per inch;
- (f) Colour: WT20013/3 Transit Blue;
- (g) Care: machine washable cold, Gentle cycle, tumble dry-low.

E6.6 Pocketing

- (a) Fiber: commercial quality, perma press pocketing, Dominion Textile Beaujean A9086 or equivalent must be used;
- (b) Colour: natural or pale blue;
- (c) Care: washable and tumble dry.

E6.7 Notions

- (a) Zipper: YKK #5cm, metal zipper, colour to match outer fabric;
- (b) Hook and bar closure: rust proof, black, good commercial quality;

- (c) Thread: spun polyester, size 40 colour to match fabric.

Construction:

- E6.8 Shorts are to be factory permanent pressed along front and back creaselines. Style is a double pressed pleated dress short with slash pockets and elasticized side waist. Cut to allow comfort when in the seated position.
- E6.9 Seams:
 - (a) All seam allowances, at least 3/8" wide, shall be serged, seamed and pressed open;
 - (b) Stitches shall present a regular even appearance without puckers;
 - (c) There shall be not less than 3 or more than 4 stitches per cm.;
 - (d) The specified thread shall be used;
 - (e) Seat seams to be sewed with flat stitch machine;
 - (f) Allow 5cm outlets in seams for any necessary alterations.
- E6.10 Front Zipper:
 - (a) Right fly front closure stitching 3cm from front edge;
 - (b) Bar tacked at lower edge;
 - (c) Stitch at the waistband seam and fly front to be deluxe AA@ thread not less than 12 stitches to the inch.
- E6.11 Waistband:
 - (a) Self fabric, interfaced. Finished at 4cm wide;
 - (b) Elastic is inserted at side waist between center of each side back and the front pleat, to allow for 3 extra inches of expansion at the waist. See drawing.
- E6.12 Closure at fly with hook and bar closure and button safety closure on fly lining.
- E6.13 Hems:
 - (a) Lower edge of pants are to be serged and blindstitched with 4 cm hem allowance;
 - (b) Side leg length 47cm for regular sizes, waist seam to lower finished edge of garment;
 - (c) Leg width at lower hem = 34cm for size 12.
- E6.14 Belt Loops:
 - (a) Seven loops are to be made of self fabric, not less than 12mm wide, nor more than 16mm wide;
 - (b) Loops must be sewn into waistband seam;
 - (c) They must accommodate a belt of at least 4cm wide;
 - (d) Center back belt loop is necessary.
- E6.15 Front Pockets:
 - (a) Slash pocket design;
 - (b) Front pockets are to have an opening of at least 17cm, but not more than 19cm.;
 - (c) The lining must allow a pocket length of at least 30cm, from waist seam;
 - (d) Bar tacking at stress points;
 - (e) The lining of the pocket shall extend to the center front of the shorts zipper placket, in such a manner that the pleats are supported underneath. See sample.
- E6.16 Marking:

- (a) Each pair of Women's shorts shall have a durable label sewn on to the inside pant on the left front pocket lining. It shall contain the following information:
 - (i) manufacturer's identification;
 - (ii) date of manufacture;
 - (iii) size code.

E6.17 Care Instructions:

- (a) Each pair of pants shall have a durable label sewn into the inside pant on the left front pocket lining detailing care requirements consistent with all components of the finished garment;
- (b) Women's Pleated Shorts shall be machine washable and dryable.

E6.18 Hang Tags available from the manufacturers of the garment's components, describing the characteristics and care of the Teflon coating and fabric shall be attached to each garment.

E6.19 Pressing:

- (a) All seams shall be properly pressed and the finished garment shall be pressed to the best commercial standards.

E6.20 Union Label:

- (a) The Contractor shall be a Union Shop and each pair of shorts shall bear a union label affixed to the inside body of the finished garment.

E6.21 Packaging:

- (a) Shorts shall be packaged in boxes containing one size only with the size clearly shown on the outside of the box.

WINNIPEG TRANSIT '97
WOMEN'S WESTERN PANT
DRAWING # WP1

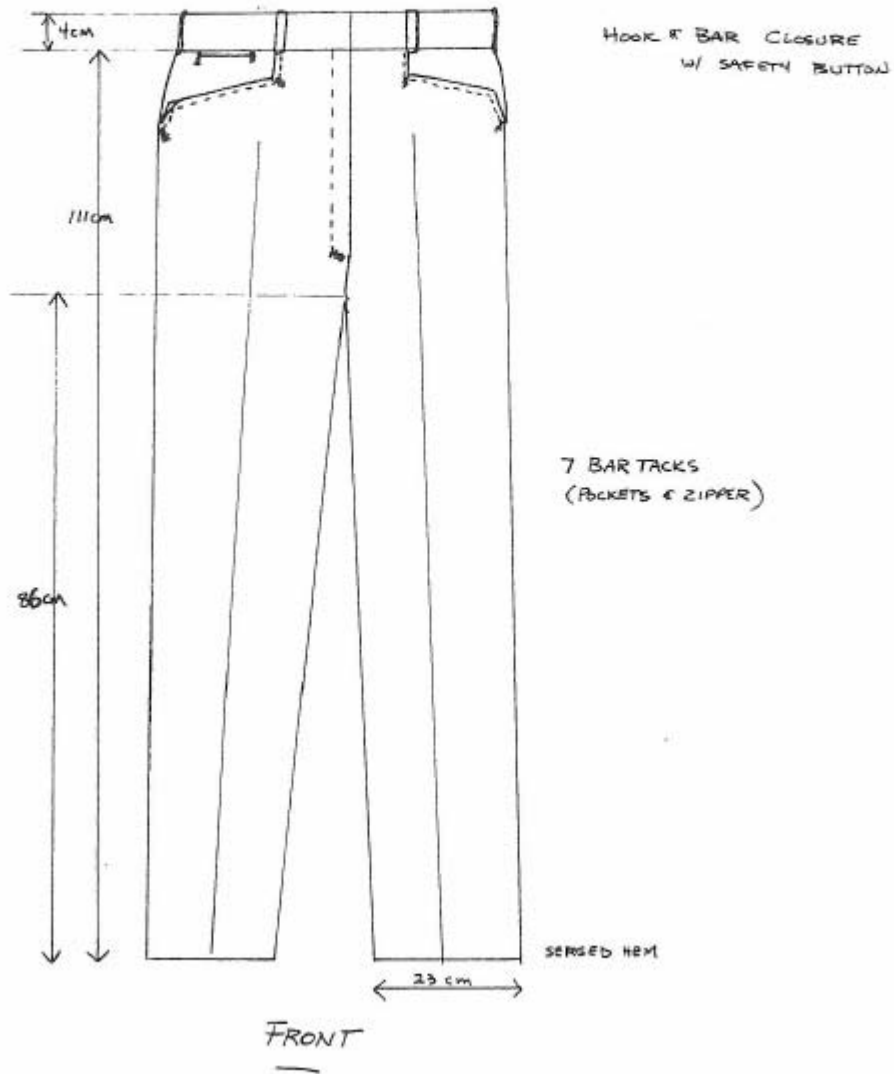

WINNIPEG TRANSIT '97
WOMEN'S WESTERN PANT
DRAWING # WP2

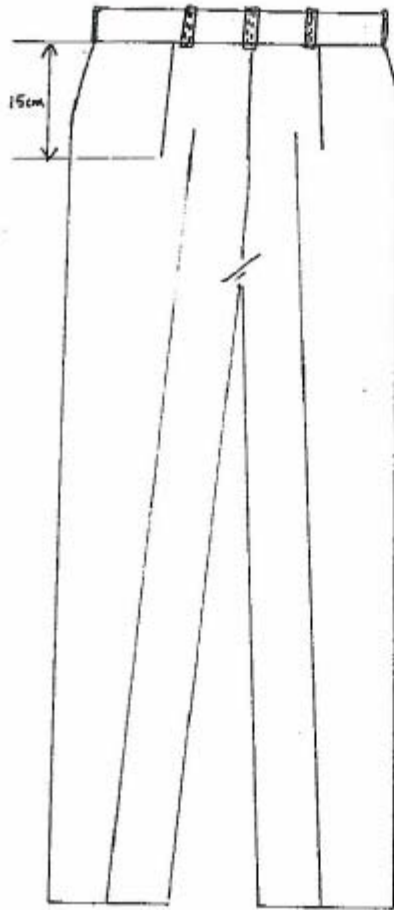

BACK

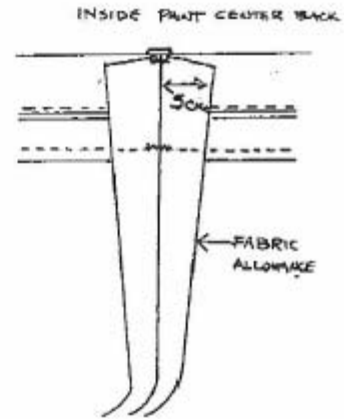

WINNIPEG TRANSIT '97
MEN'S WESTERN PANT

DRAWING # MP1

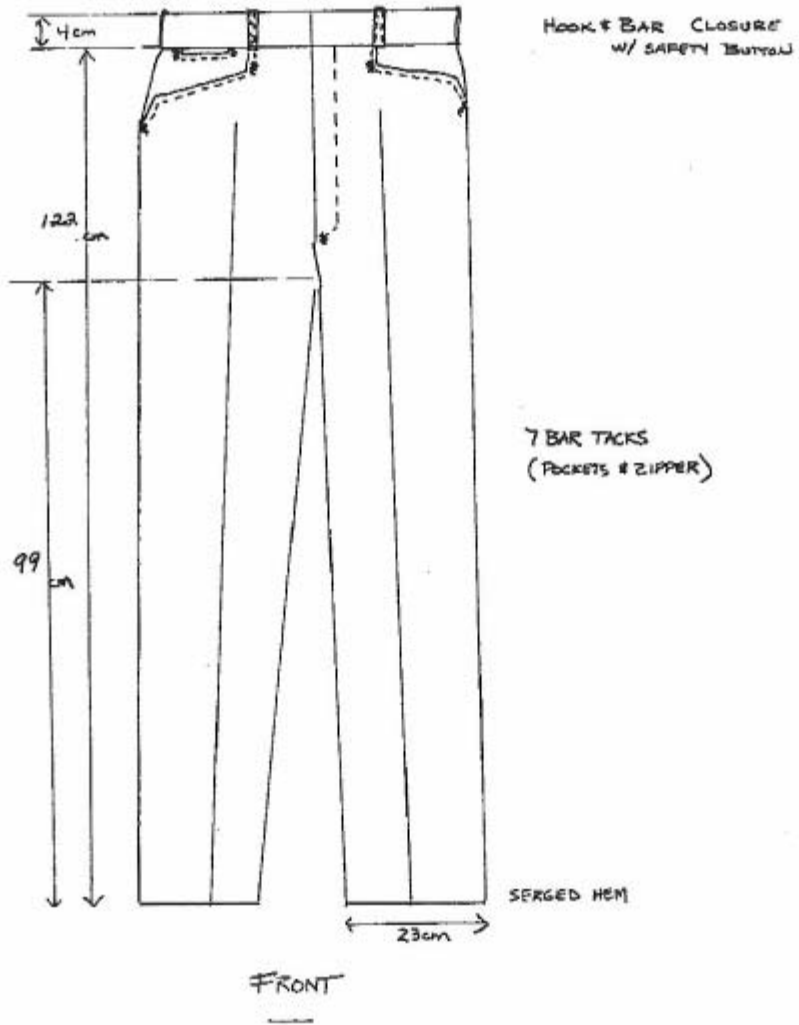

WINNIPEG TRANSIT '97
MEN'S WESTERN PANT

DRAWING # MP2

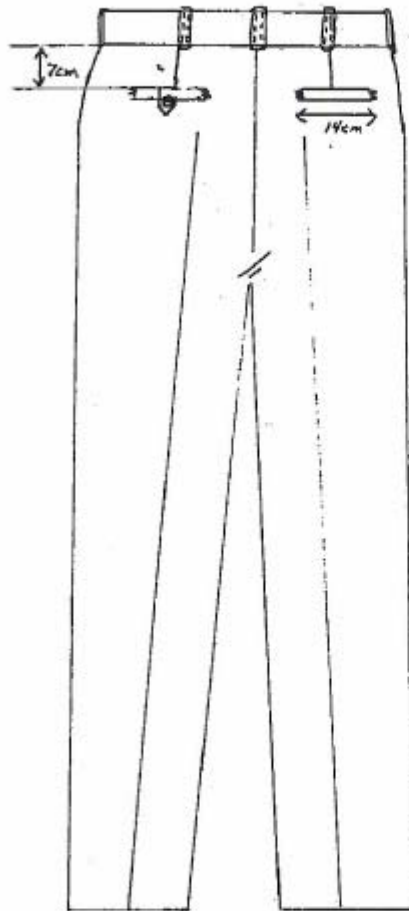

BACK

