

- NOTES:**
1. WATERMAIN IS CATHODICALLY PROTECTED, USE CAUTION WHEN EXCAVATING
 2. SIDEWALK RENEWAL TO BE DIRECTED BY CONTRACT ADMINISTRATOR
 3. MODIFIED BARRIER CURB TO BE USED FOR CURB RENEWAL AT RADII AS DIRECTED BY CONTRACT ADMINISTRATOR

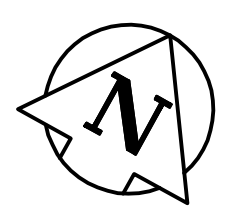
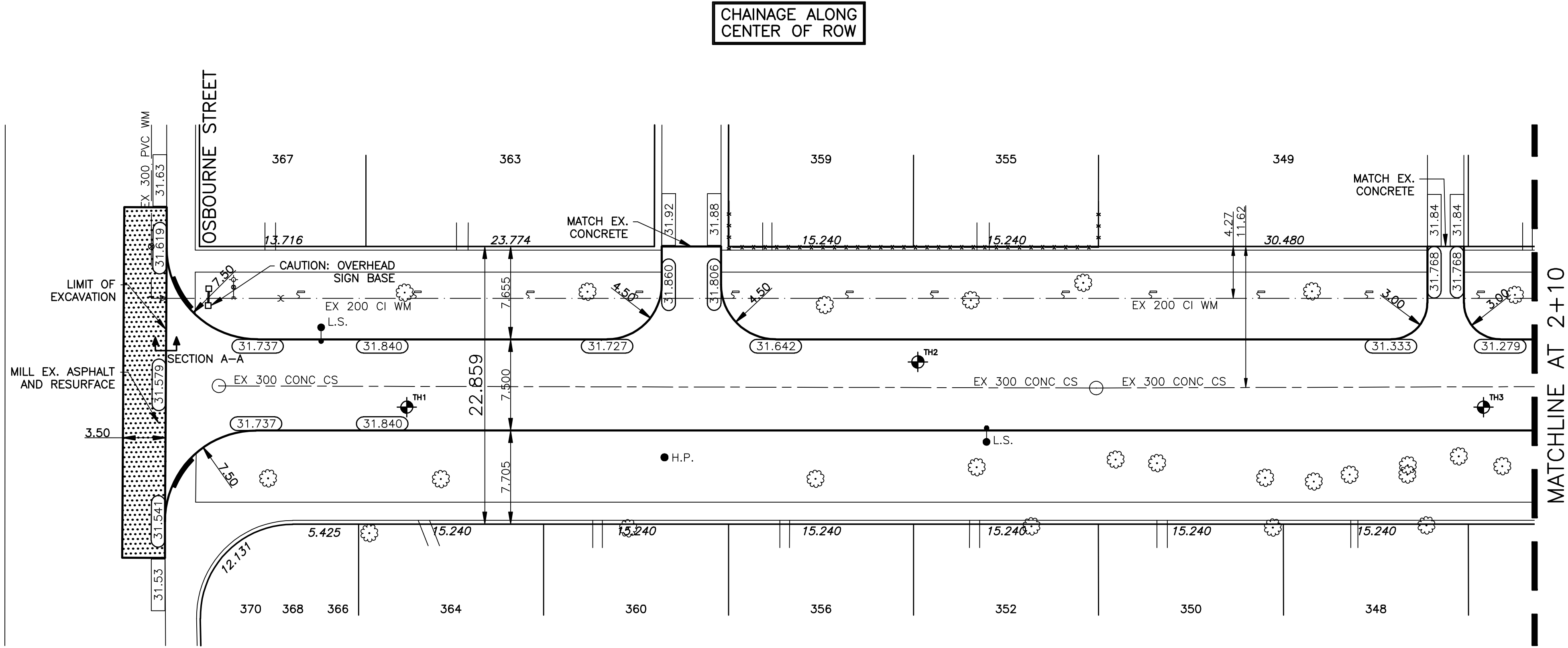
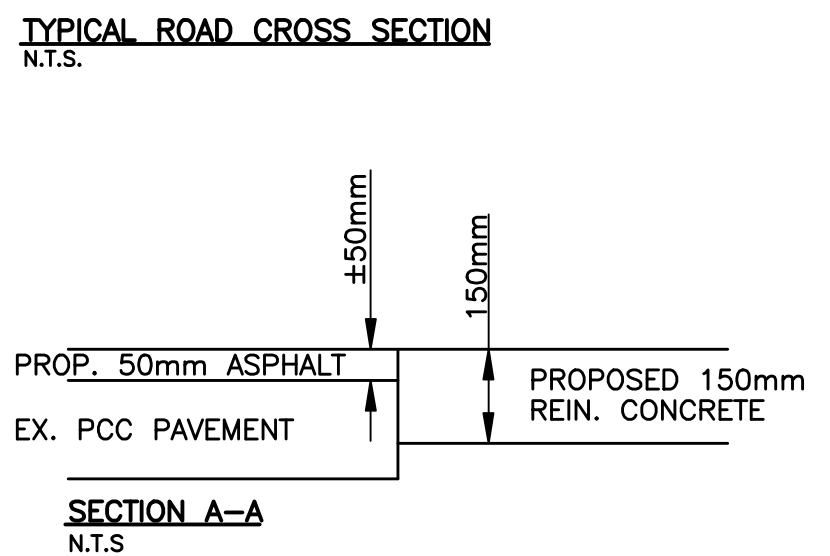
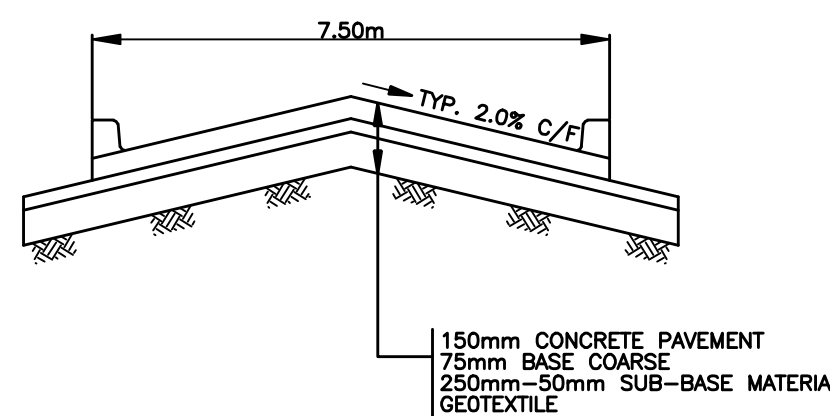

BENCHMARK:
 N.E. COR. OSBORNE ST. & BALFOUR AVE., TBLT. IN S.
 CONC. FOUNDATION OF NO. 760 OSBORNE ST., 0.8 M E. &
 0.2 M BELOW BRICK OF S.W. COR. OF BLDG. (DRIFTWOOD APTS.)

METRIC
 WHOLE NUMBERS INDICATE MILLIMETRES
 DECIMALIZED NUMBERS INDICATE METRES

EXISTING	LEGEND - PLAN	PROPOSED	EXISTING	LEGEND - PLAN	PROPOSED	EXISTING	LEGEND - PROFILE	PROPOSED
—	WATERMAIN	—	—	HYDRO	—	—	CENTER LINE	—
—	HYDRANT	—	—	M.T.S.	—	—	NORTH GUTTER LINE	—
—	VALVE	—	—	CONCRETE	—	—	SOUTH GUTTER LINE	—
—	ANODE	—	—	ASPHALT	—	—	WATERMAIN	—
—	LAND DRAINAGE SEWER	—	—	PROPERTY LINE	—	—	VALVE	—
—	WASTE WATER SEWER	—	—	SURVEY BAR	—	—	LAND DRAINAGE SEWER	—
—	MANHOLE	—	—	TESTHOLE	—	—	WASTE WATER SEWER	—
—	CATCH BASIN	—	—	C.B. LEAD	—	—	JUNCTIONS	—
—	CURB INLET	—	—	SIDEWALK	—	—	ASPH./CONC. PAD	—
—	TRAFFIC SIGNAL	—	—	SIDEWALK RAMP	—	—	GARAGE PAD	—
—	GAS	—	—	ELEVATIONS	—	—		—
—		—	—		—	—		—

LOCATION APPROVED			
SUPPLY	U/G STRUCTURES	DATE	
COMMITTEE			
NOTE:			
LOCATION OF UNDERGROUND STRUCTURES AS SHOWN ARE BASED ON THE BEST INFORMATION AVAILABLE BUT NO GUARANTEE IS GIVEN THAT ALL EXISTING UTILITIES ARE SHOWN OR THAT THE GIVEN LOCATIONS ARE EXACT. CONFIRMATION OF EXTENSIVE AND EXACT LOCATION OF ALL SERVICES MUST BE OBTAINED FROM THE INDIVIDUAL UTILITIES BEFORE PROCEEDING WITH CONSTRUCTION.			

B.M. ELEV.	CWBM: 53-022		
	232.189		
GENIVAR			
200 TACHE AVENUE WINNIPEG, MANITOBA R2H 1A7 PH: (204)-477-6650 FAX: (204)-474-2864			
DESIGNED BY	R.H.	CHECKED BY	S.M.
DRAWN BY	R.H.	APPROVED BY	I.McK.
HOR. SCALE:	1:250	RELEASED FOR CONSTRUCTION	
VERT. SCALE:	1:10	DATE	
1	BID DRAWING	MAR/09	R.H.
NO.	REVISIONS	DATE	BY

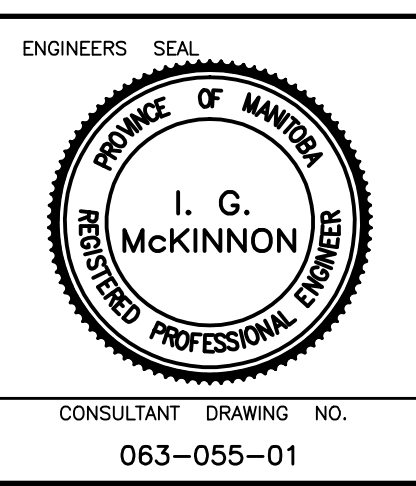

THE CITY OF WINNIPEG
PUBLIC WORKS DEPARTMENT

2009 RESIDENTIAL STREET RENEWALS
CLARE AVENUE
STREET RECONSTRUCTION
 FROM OSBOURNE STREET
 TO MATCHLINE AT 2+10



CITY DRAWING NO.	
SHEET	1 OF 2
	190-2009

APR 2009