

**ALLEY PAVEMENT PROFILE**  
SCALE: 1:250 HOR  
1:10 VER

MATCH LINE  
STA 3+00

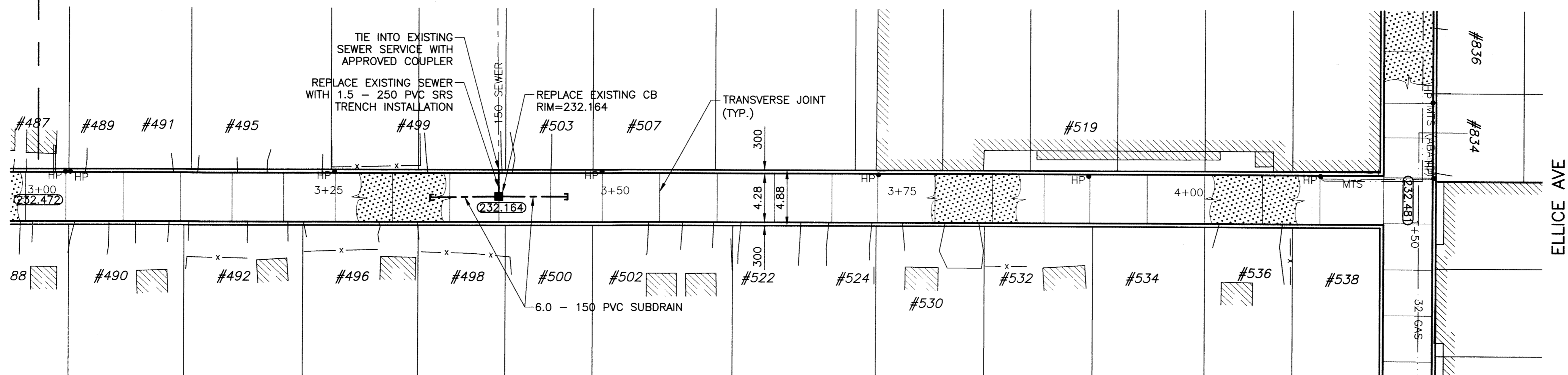

**ALLEY PAVEMENT PLAN**  
SCALE: 1:250 HOR

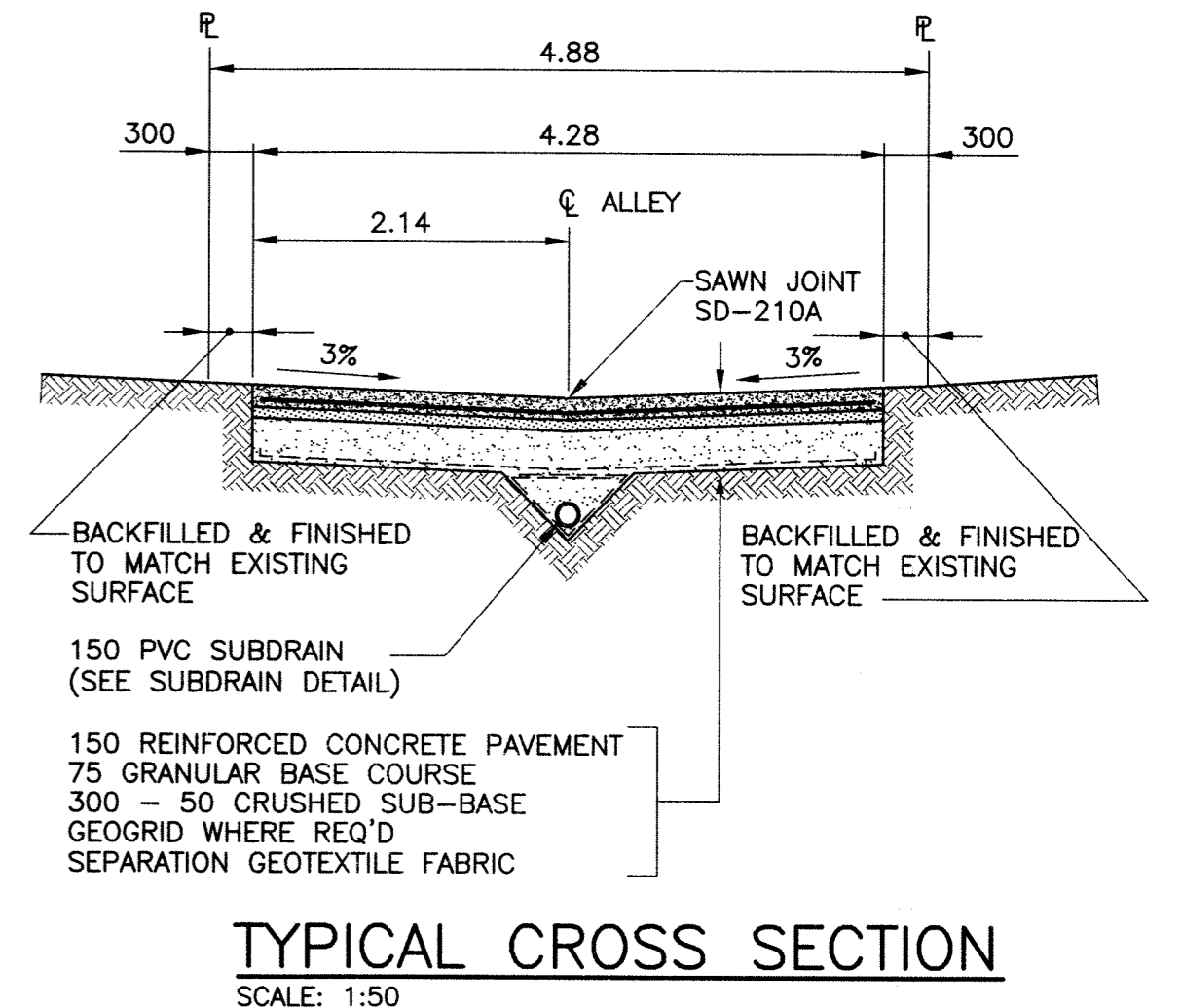

**TYPICAL CROSS SECTION**  
SCALE: 1:50

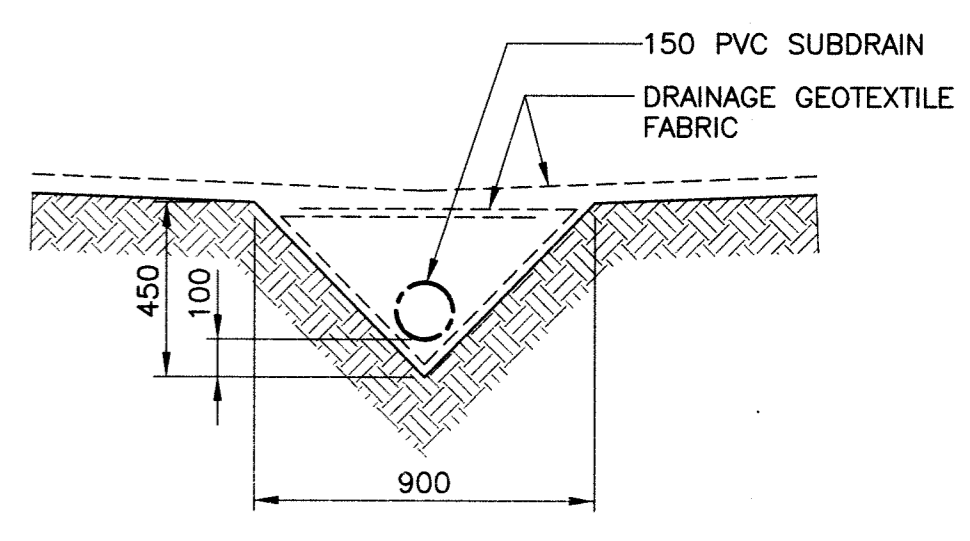

**SUBDRAIN DETAIL**  
SCALE: 1:20

- NOTE:**
1. STATION CHAINAGE IS BASED ON CENTERLINE OF ALLEY RIGHT OF WAY.
  2. ADJUST MH AND CB RIMS TO NEW GRADES.
  3. PLUG SUBDRAINS AT TERMINAL ENDS.
  4. REGRADE EXISTING PRIVATE SIDEWALKS AS REQUIRED.
  5. INSTALLATION OF LIP CURBS AND THEIR EXTENTS TO BE DETERMINED BY THE CONTRACT ADMINISTRATOR.
  6. LIGHT STANDARDS, HYDRO POLES AND ANCHORS MAY REQUIRE TEMPORARY SUPPORT/REMOVAL OR REPLACEMENT AT THE CONTRACTOR'S EXPENSE.
  7. ISOLATE ALL POLES, BASES AND PILES WITHIN ALLEY RIGHT OF WAY (SD-228C)
  8. AVOID DAMAGE TO EXISTING TREES WITHIN THE LIMITS OF CONSTRUCTION.

**PROPERTY LIMITS DELINEATION**

DELINEATION OF PROPERTY LIMITS AS SHOWN ON THIS DWG DOES NOT REPRESENT A "LEGAL SURVEY". KGS GROUP MAKES NO REPRESENTATION OR WARRANTY AS TO THE ACCURACY OF PROPERTY LIMITS DELINEATED ON THIS DWG, NOR ON THE DIMENSIONAL ACCURACY OF DWG FEATURES RELATIVE TO THOSE PROPERTY LIMITS.

**WARNING**

1. NOTIFY THE GAS COMPANY OF THE PROPOSED LOCATION OF EXCAVATION.
2. TAKE PRECAUTION TO AVOID DAMAGE TO GAS COMPANY INSTALLATIONS.
3. SEE PROVINCIAL REGULATION 210/72 FOR DETAILS.

**METRIC**

WHOLE NUMBERS INDICATE MILLIMETRES  
DECIMALIZED NUMBERS INDICATE METRES

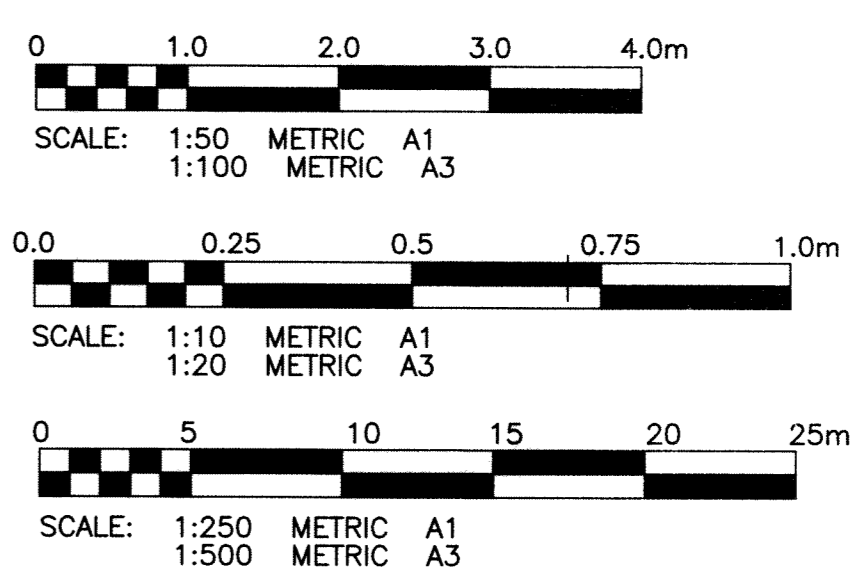
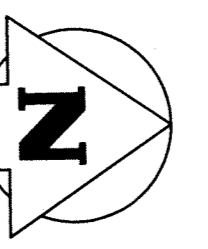

F:\Projects\2009\08-0107-03\DocControl\Issued\SOURCE\dwg\09-0107-03\_0004-0007-Rev 0.dwg - Tab: 06 Plotted By: DBerche 05/05/2009 [Tue 2:40pm]

300 LWS	LAND DRAINAGE SEWER	300 LWS	CONCRETE JOINT				
250 WWS	WASTE WATER SEWER	250 WWS	TEST HOLE				
	GAS		GUY WIRE				
	HYDRO		LIGHT STANDARD				
	M.T.S.		BACK OF CURB				
150 WM	WATERMAIN	150 WM	CONCRETE				
	HYDRANT		ASPHALT				
	VALVE		SIDEWALK				
	MANHOLE		PROPERTY LINE				
	CATCH BASIN		SURVEY BAR				
	CURB INLET		GEODETIC BENCHMARK				
	POLES		ELEVATION				
EXISTING	LEGEND-PLAN	PROPOSED	EXISTING	LEGEND-PLAN	PROPOSED	EXISTING	LEGEND-PROFILE

**LOCATION APPROVED UNDERGROUND STRUCTURES**

SUPV. U/G STRUCTURES COMMITTEE DATE

**NOTE:**  
LOCATION OF UNDERGROUND STRUCTURES AS SHOWN ARE BASED ON THE BEST INFORMATION AVAILABLE BUT NO GUARANTEE IS GIVEN THAT ALL EXISTING UTILITIES ARE SHOWN OR THAT THE GIVEN LOCATIONS ARE EXACT. CONFIRMATION OF EXISTENCE AND EXACT LOCATION OF ALL SERVICES MUST BE OBTAINED FROM THE INDIVIDUAL UTILITIES BEFORE PROCEEDING WITH CONSTRUCTION.

B.M. 37-027	ELEV. 233.123
DESIGNED BY	JDF
CHECKED BY	RJH
DRAWN BY	GEL
APPROVED BY	
HOR. SCALE:	1:250
VERTICAL:	1:50
ISSUED FOR TENDER	06/05/09
NO. REVISIONS	DATE BY

**KGS CONSULTING ENGINEERS & PROJECT MANAGERS GROUP**

WINNIPEG (204) 896-1209  
THUNDER BAY (807) 345-2233

DESIGNED BY: JDF  
CHECKED BY: RJH  
DRAWN BY: GEL  
APPROVED BY: [Signature]

HOR. SCALE: 1:250  
VERTICAL: 1:50

ISSUED FOR TENDER: 06/05/09  
NO. REVISIONS: [ ] DATE: [ ] BY: [ ]



**THE CITY OF WINNIPEG PUBLIC WORKS DEPARTMENT TRANSPORTATION ENGINEERING DIVISION**

PROJECT TITLE: 2009 ALLEY RENEWAL PROGRAM  
SHEET OF: 06 15

BURNELL ST./ARLINGTON ST. ALLEY ST. MATTHEWS AVE. TO ELLICE AVE STA. 3+00.0 TO STA. 4+20.0

CITY DRAWING NUMBER: 0006

