

MATERIALS

- WOOD - VERTICAL GRAIN CLEAR SITKA SPRUCE OR B.C. RED CEDAR
- FINISH - SIKKENS CETOL 1 no. 078 NATURAL
- METAL FINISH - PRIME WITH RUSTOLEUM no.769. FINISH WITH SAPOLIN BLACK WROUGHT FINISH

TITLE

TACHE BENCH with ARMS

SCD - 138

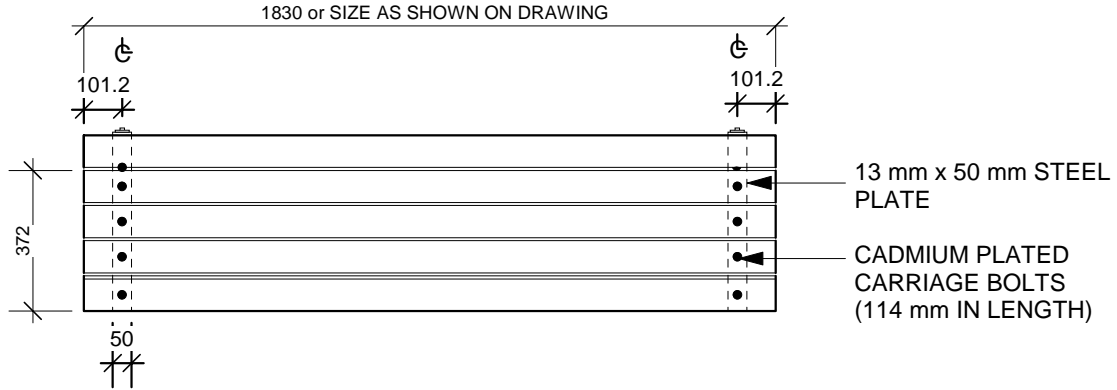

PLAN VIEW

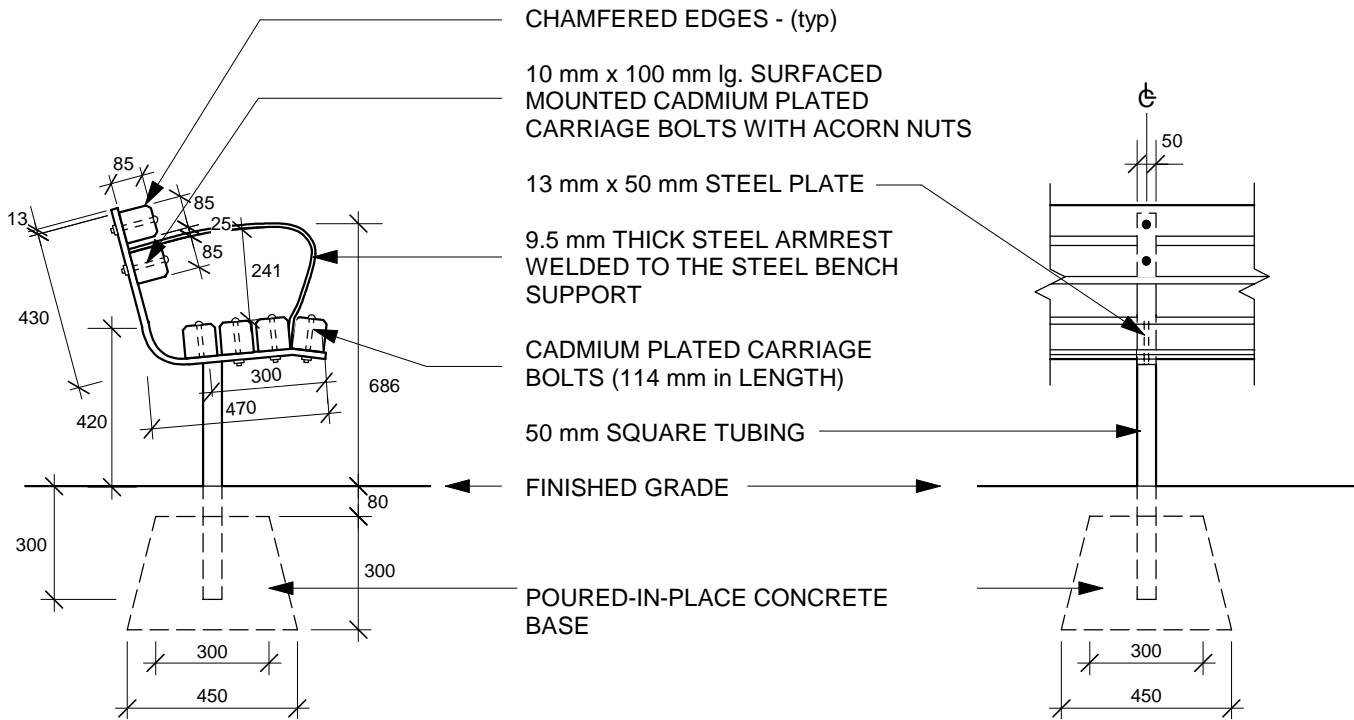

SIDE ELEVATION

FRONT ELEVATION

NOTE: ALL DIMENSIONS SHOWN ARE IN MILLIMETERS

1:20
DATE : JUNE 2003
DRAWN BY: SV

THE CITY OF WINNIPEG
Planning, Property and Development Department
Planning and Land Use Division
Unit 15 - 10 Fort Street, Winnipeg, MB, R3C 4X5

