

NOTES:

USING A TAPE MEASURE FROM EDGE 'A' OF LIP TO END OF CRACK 1 3/4" MAXIMUM

TYPE A

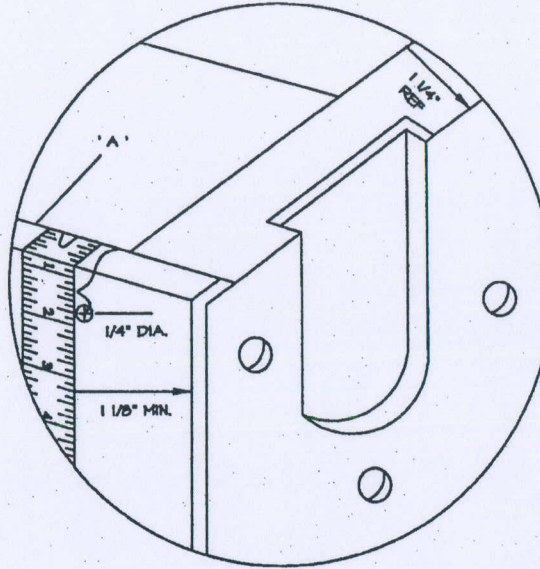

TYPE B

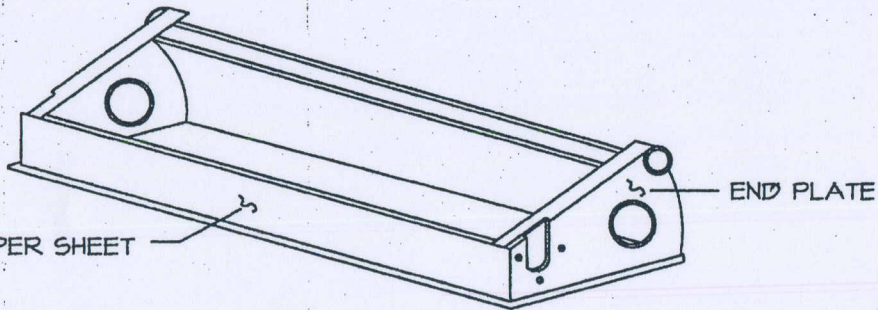
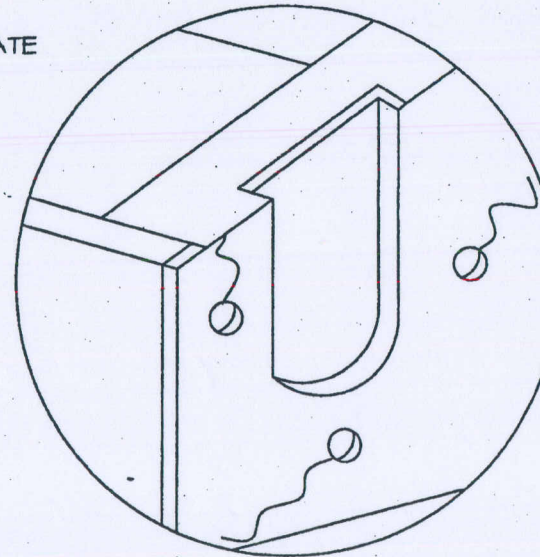

WRAPPER SHEET

END PLATE

NO.	REVISION	BY	DATE
SEALS			

DESIGNED BY R. Peters	CHECKED BY	APPROVED
DATE: SEPT. 29/99	USER APPROVAL	



THE CITY OF WINTHROP  
PUBLIC WORKS DEPARTMENT  
BUILDING SERVICES DIVISION  
100 MAIN STREET, MAIN FLOOR  
WPG, ME, 03091-1A4  
Phone # 888 - 7266

PROJECT

MONTGOMERY ESCALATOR STEP  
BOX DETAIL

SHEET TITLE

PLAN, DETAILS

SCALE  
N.T.S.

SHEET NO.  
A-1