

A1 SIZE 23.4" x 33.1" (594mm x 841mm) PLOT: 10/03/24 11:02:11 AM AECOM FILE NAME: 0265-412-00\_01-S-0561\_RX.dwg Saved By: crossmanc

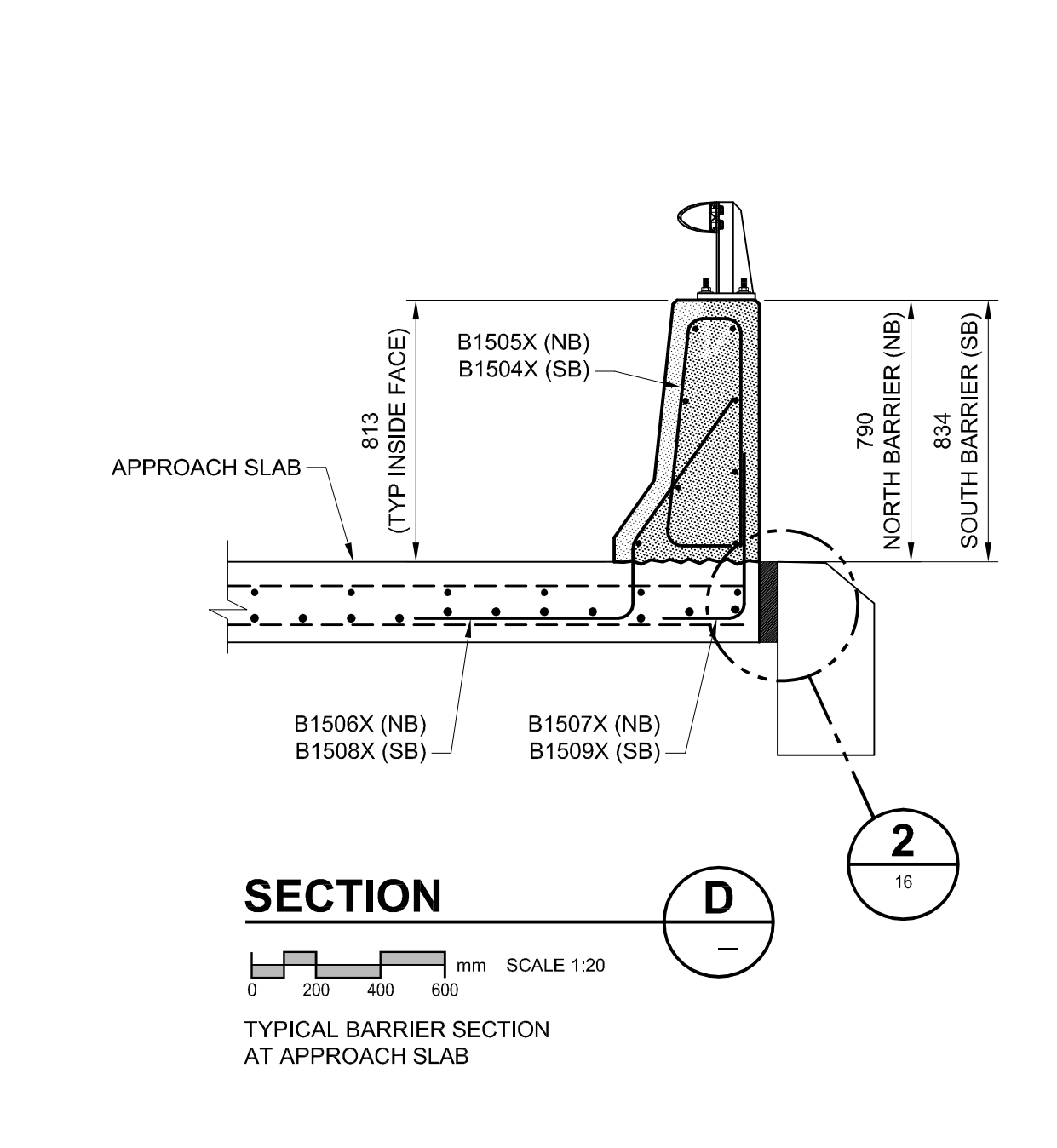
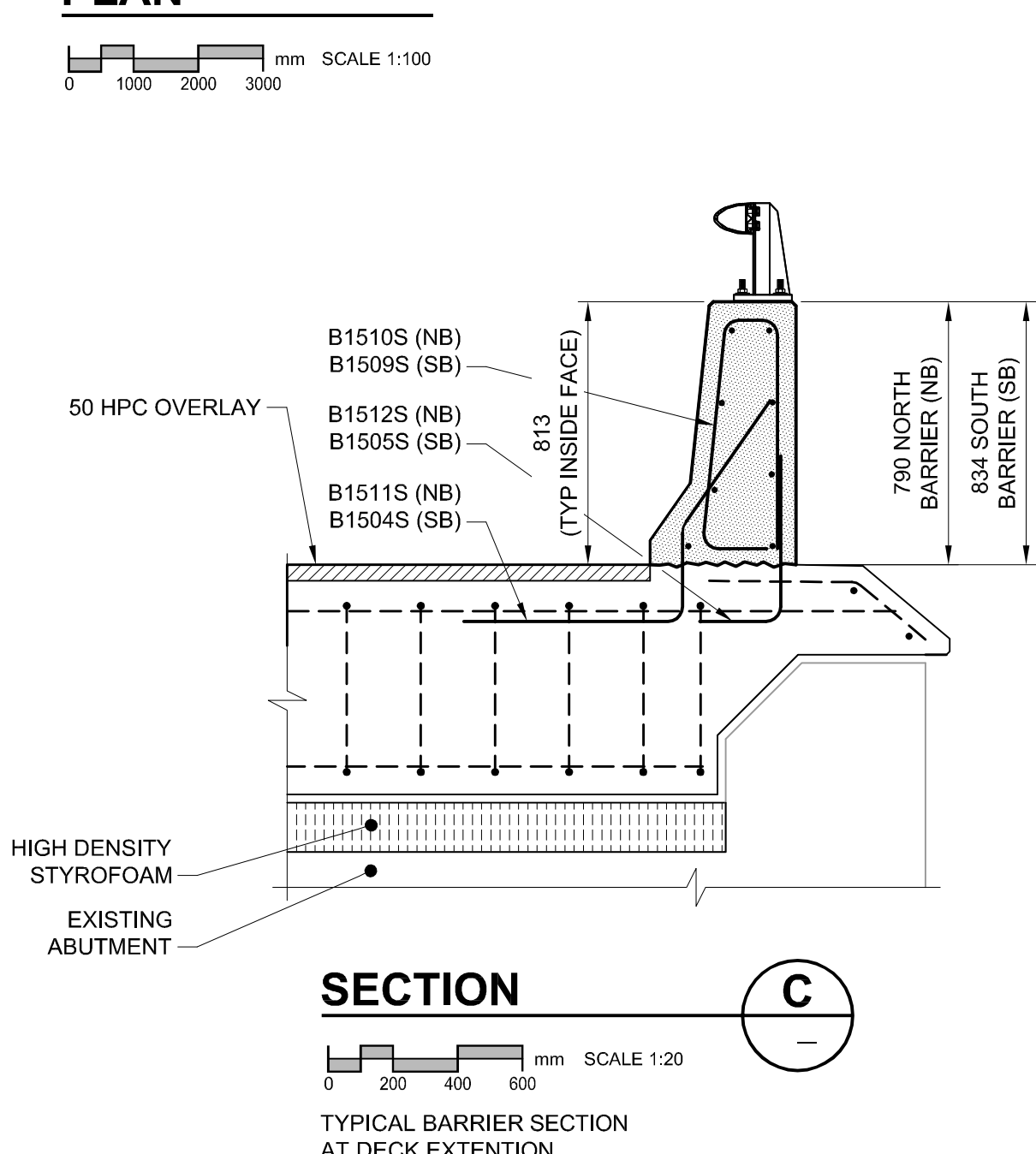
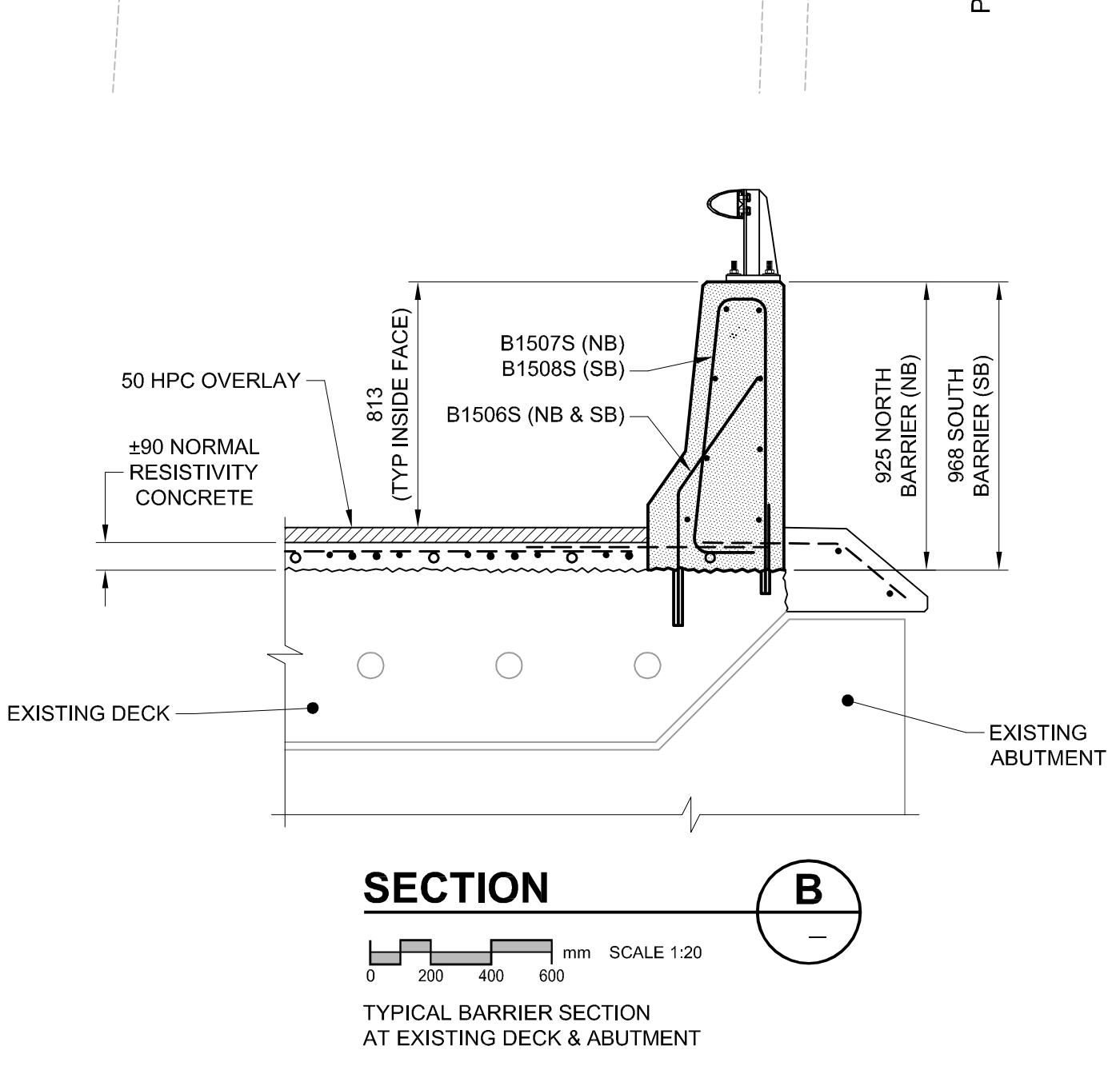
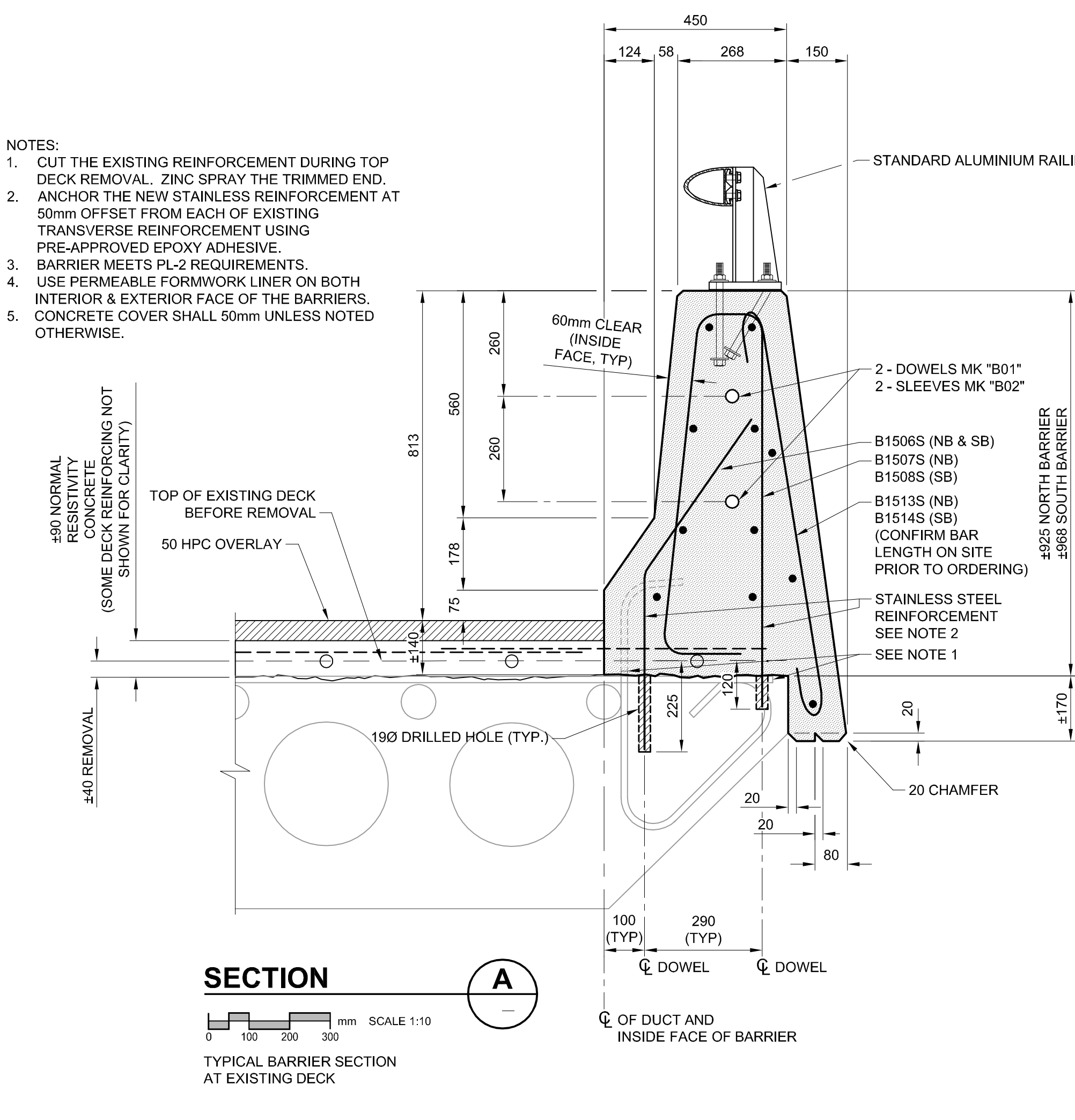
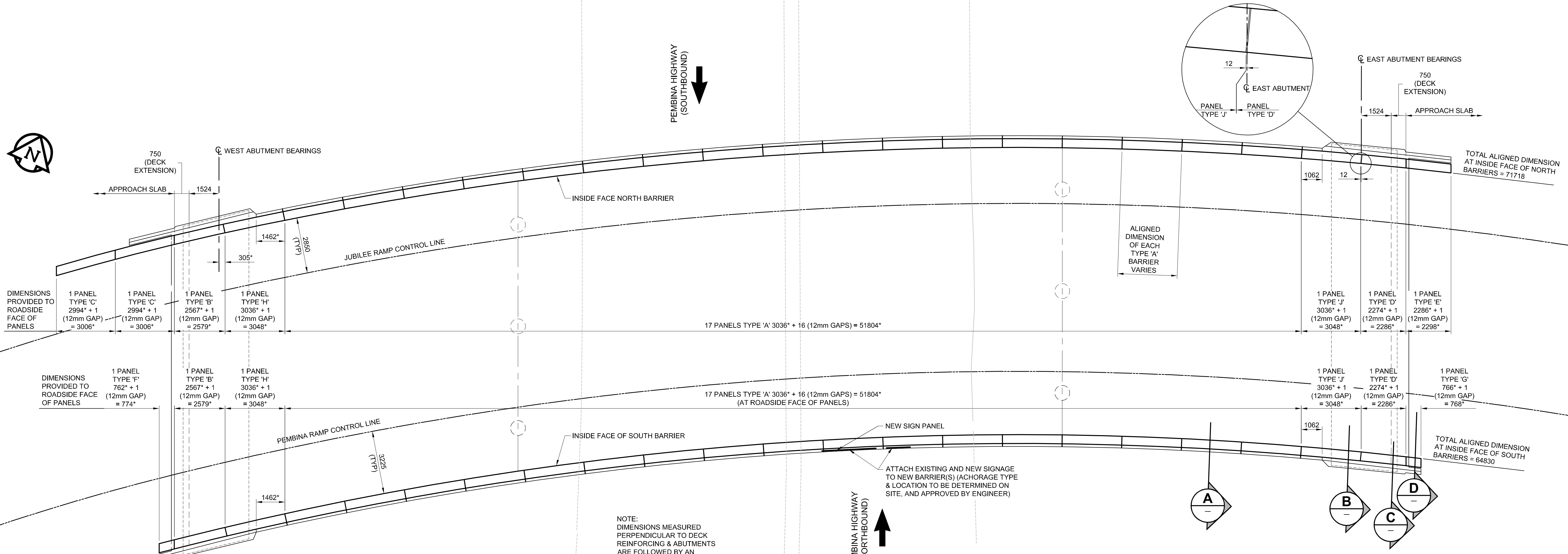

**METRIC**  
WHOLE NUMBERS INDICATE MILLIMETRES  
DECIMALIZED NUMBERS INDICATE METRES

LOCATION APPROVED UNDERGROUND STRUCTURES		BM 00-000 ELEV 200.000m
SUPR. U/G STRUCTURES COMMITTEE	DATE	
NOTE: LOCATION OF UNDERGROUND STRUCTURES AS SHOWN ARE BASED ON THE BEST INFORMATION AVAILABLE. BUT NO GUARANTEE IS GIVEN THAT ALL EXISTING UTILITIES ARE SHOWN OR THAT THE GIVEN LOCATIONS ARE EXACT. CONFIRMATION OF EXISTENCE AND EXACT LOCATION OF ALL SERVICES MUST BE OBTAINED FROM THE INDIVIDUAL UTILITIES BEFORE PROCEEDING WITH CONSTRUCTION.		
0	ISSUED FOR CONSTRUCTION	10/03/24 CPK
A	ISSUED FOR 100% REVIEW	10/03/08 DJH
NO.	REVISIONS	YYMMDD BY

<b>AECOM</b>		This drawing has been prepared for the use of AECOM's client and may not be used, reproduced or relied upon by third parties, except as agreed by AECOM and its client, as required by law or for use by governmental reviewing agencies. AECOM accepts no responsibility, and denies any liability whatsoever, to any party that modifies this drawing without AECOM's express written consent. Do not scale this document. All measurements must be obtained from stated dimensions.	
DESIGNED BY	AP	CHECKED BY	SBB / CGC
DRAWN BY	DJH	APPROVED BY	
HOR. SCALE	AS NOTED	RELEASED FOR CONSTRUCTION	
VERT. SCALE	AS NOTED		
DATE	YYMMDD	DATE	

**APECM**  
Certificate of Authorization  
AECOM Canada Ltd.  
Original dated on: \_\_\_\_\_  
No. 4671 Date: 2010/03/24

PROFESSIONAL'S SEAL  
PROVINCE OF MANITOBA  
ORIGINAL SIGNED  
**A. POCHANART**  
Member 9007  
MARCH 24/2015  
REGISTERED PROFESSIONAL ENGINEER  
CONSULTANT DRAWING NO.  
0265-412-00\_01-S-0561\_RX.dwg

**THE CITY OF WINNIPEG**  
PUBLIC WORKS DEPARTMENT  
ENGINEERING DIVISION

**JUBILEE AVENUE OVERPASS REHABILITATION**

**CONCRETE BARRIERS LAYOUT & REINFORCING DETAILS I**

CITY DRAWING NUMBER: B124-10-11  
SHEET 11 OF 51  
DRAWING No. 11 REV 0

BID OPPORTUNITY NO. 133-2010