

**NOTES:**

1. LOCATION OF PATHWAY, DITCHES, BOULEVARD, AND CULVERTS TO BE FINALIZED IN THE FIELD BY CONTRACT ADMINISTRATOR
2. CONTRACTOR TO TAKE PRECAUTIONARY STEPS TO AVOID DAMAGE FROM CONSTRUCTION ACTIVITIES TO TREES WITHIN THE LIMITS OF CONSTRUCTION
3. REGRADEING OF EXISTING DITCHES TO BE DIRECTED BY CONTRACT ADMINISTRATOR
4. RENEWAL OF EXISTING APPROACHES, PAVEMENT, CURBS, SIDEWALKS, CULVERTS, DITCHES AND BOULEVARD TO BE DIRECTED BY CONTRACT ADMINISTRATOR

**CHAINAGE ALONG CENTER OF PATH**  
**ARCHIBALD STREET**

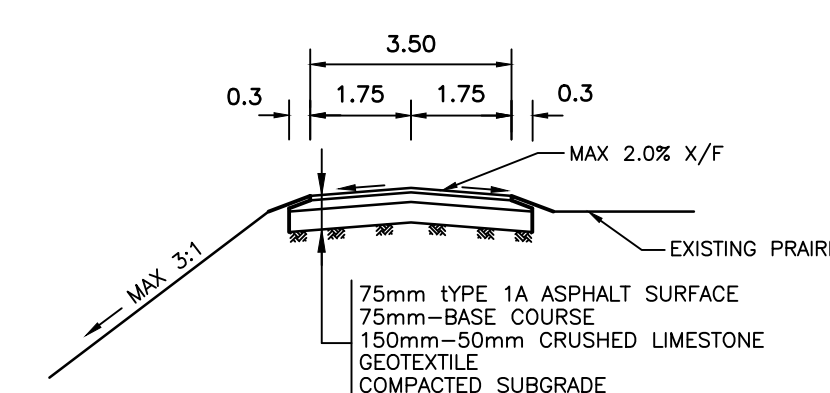
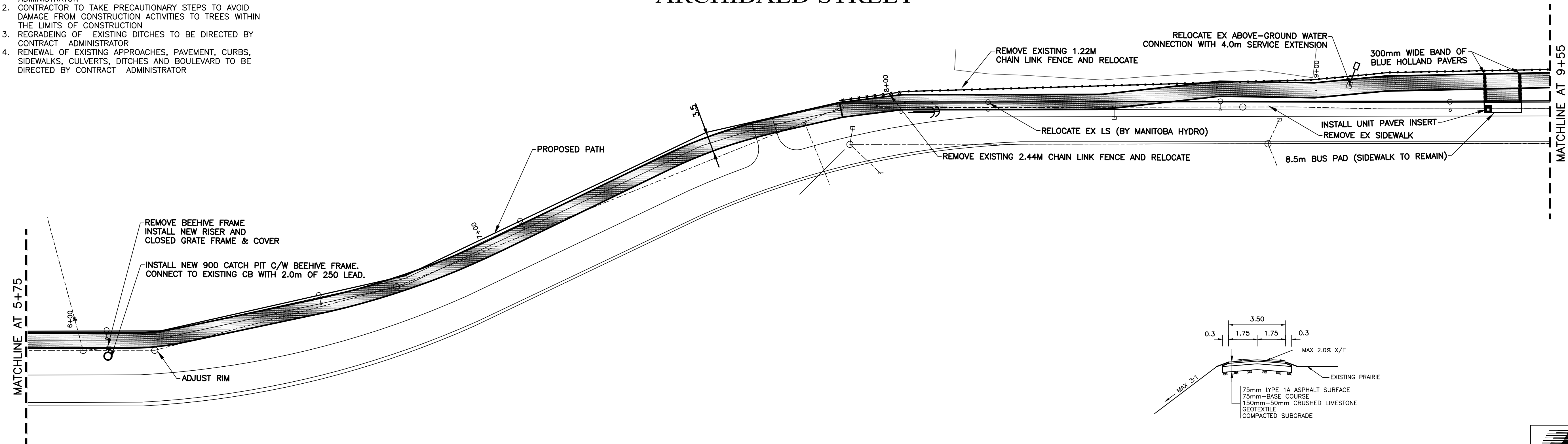

METRIC  
WHOLE NUMBERS INDICATE MILLIMETRES  
DECIMALIZED NUMBERS INDICATE METRES

TYPICAL MULTI-USE PATH CROSS SECTION  
N.T.S.



EXISTING	LEGEND - PLAN	PROPOSED	EXISTING	LEGEND - PLAN	PROPOSED	EXISTING	LEGEND - PROFILE	PROPOSED
---	WATERMAIN	---	---	HYDRO	---	---	CENTER LINE	---
⊕	HYDRANT	⊕	---	M.T.S.	---	---	NORTH GUTTER LINE	---
⊕	VALVE	⊕	---	CONCRETE	---	---	SOUTH GUTTER LINE	---
---	LAND DRAINAGE SEWER	---	---	ASPHALT	---	---	WATERMAIN	---
---	WASTE WATER SEWER	---	---	PROPERTY LINE	---	---	VALVE	---
○	MANHOLE	○	---	SURVEY BAR	---	---	LAND DRAINAGE SEWER	---
□	CATCH BASIN	□	---	CURB STOP	---	---	WASTE WATER SEWER	---
△	CURB INLET	△	---	C.B. LEAD	---	---	JUNCTIONS	---
---	TRAFFIC SIGNAL	---	---	SIDEWALK	---	---	CULVERT	---
---	STEAM HT.	---	---	SIDEWALK RAMP	---	---	ASPH./CONC. PAD	---
---	GAS	---	---	ELEVATIONS	---	---	GARAGE PAD	---

NO.	REVISIONS	DATE	BY

**GENIVAR**  
10 PRAIRIE WAY WINNIPEG, MANITOBA R2J 3J8  
PH: (204)-477-8650 FAX: (204)-474-2864

DESIGNED BY: MBS  
DRAWN BY: MBS  
HOR. SCALE: 1:500  
VERT. SCALE: 1:50  
DATE: JUNE 2010

CHECKED BY: SM  
APPROVED BY: IMcK  
RELEASED FOR CONSTRUCTION  
DATE: JUNE 2010

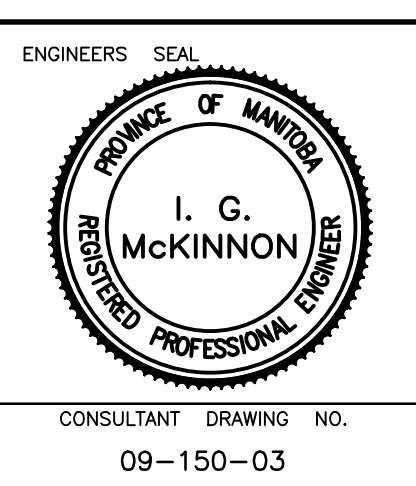

Winnipeg THE CITY OF WINNIPEG PUBLIC WORKS DEPARTMENT

2010 ACTIVE TRANSPORTATION INFRASTRUCTURE STIMULUS FUND ARCHIBALD MULTI-USE PATH  
FROM MATCHLINE AT STATION 5+90 TO MATCHLINE AT STATION 9+55

CITY DRAWING NO. N/A  
SHEET 3 OF 8  
TENDER NO. 272-2010