

ALLEY PAVEMENT PROFILE
SCALE: 1:250 HOR
1:10 VER

MATCH LINE
STA 3+62.5

PHASE 2

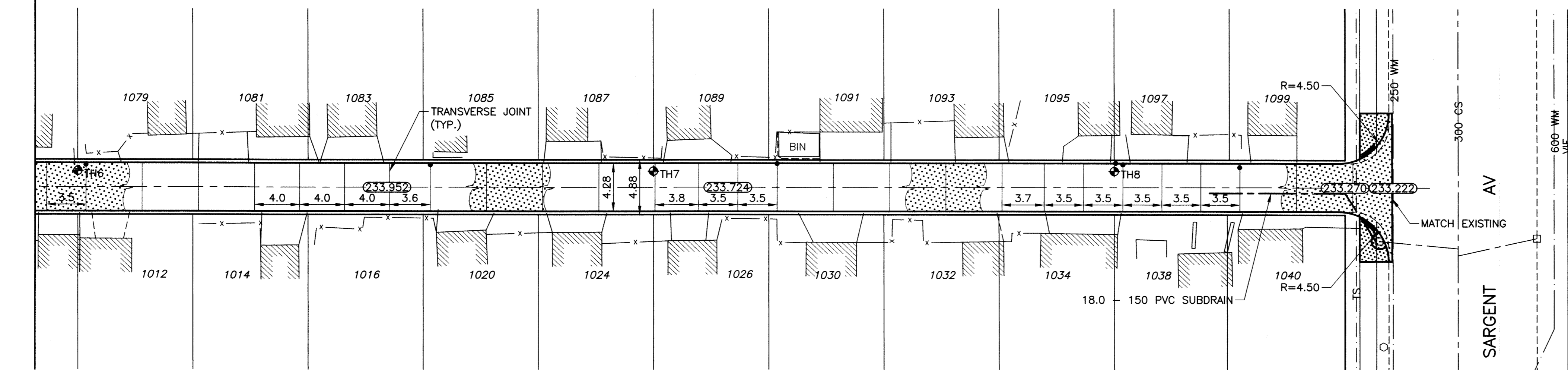

ALLEY PAVEMENT PLAN
SCALE: 1:250 HOR

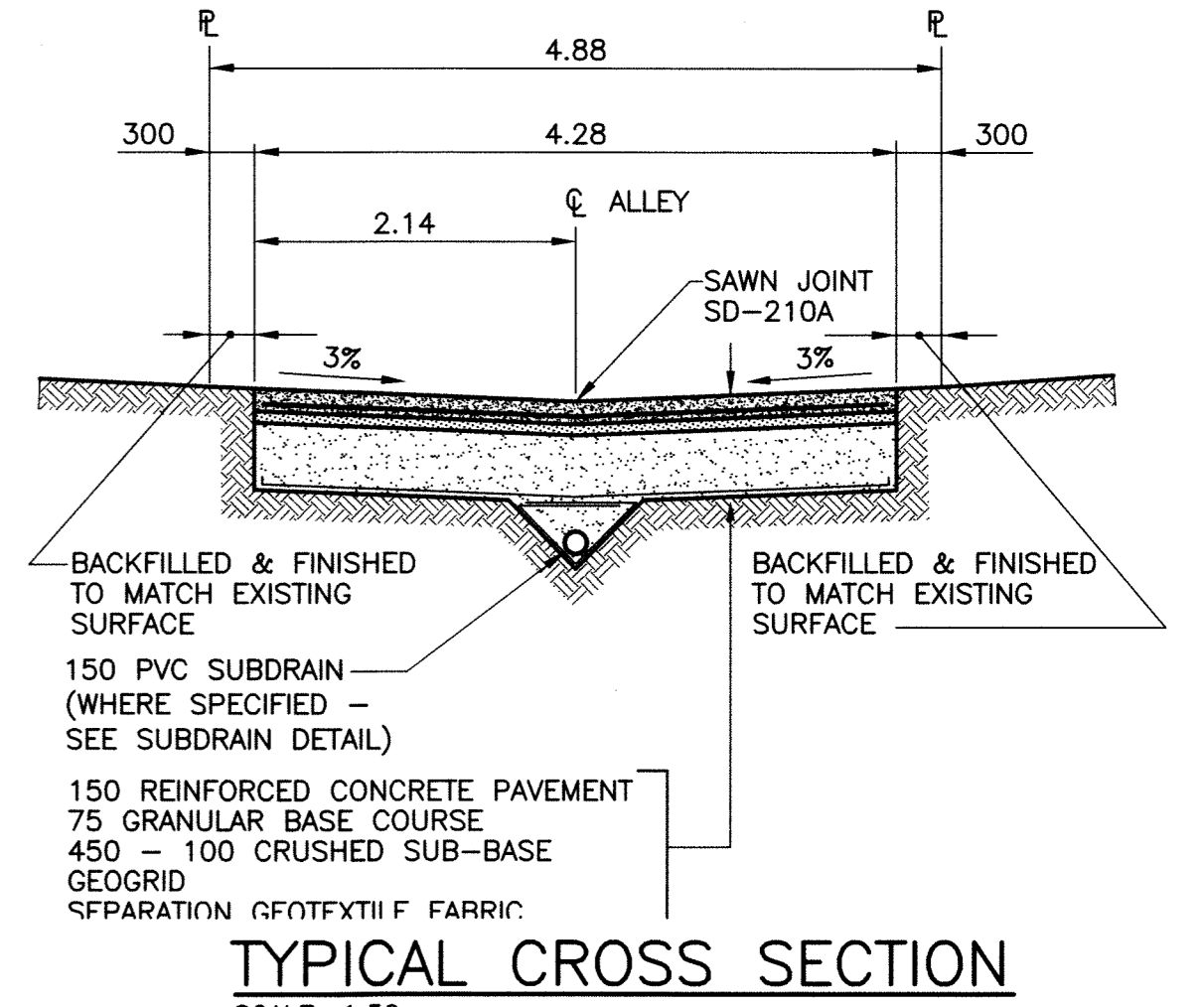

TYPICAL CROSS SECTION
SCALE: 1:50

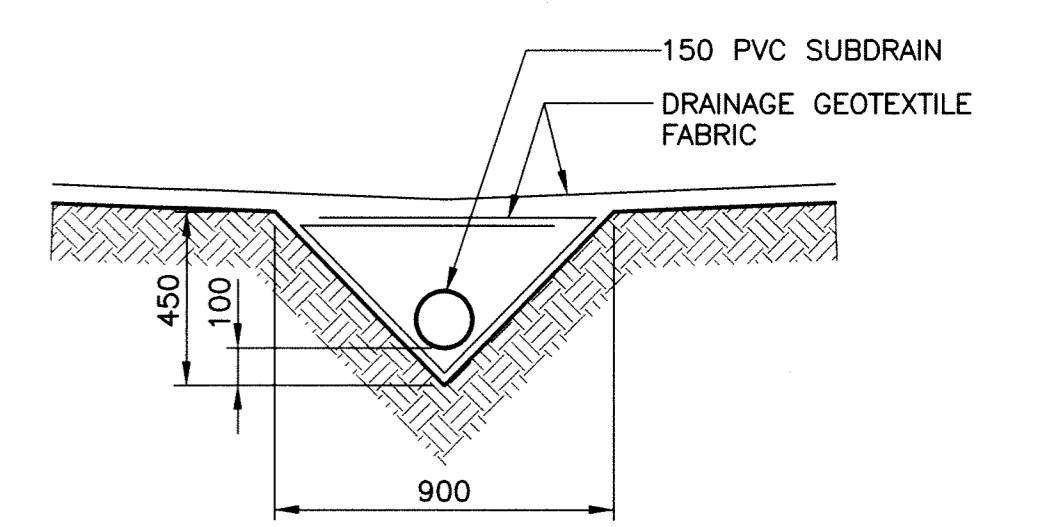

SUBDRAIN DETAIL
SCALE: 1:20

- NOTE:**
1. STATION CHAINAGE IS BASED ON CENTERLINE OF ALLEY RIGHT OF WAY.
 2. ADJUST MH AND CB RIMS TO NEW GRADES.
 3. PLUG SUBDRAINS AT TERMINAL ENDS.
 4. REGRADE EXISTING PRIVATE SIDEWALKS AS REQUIRED.
 5. INSTALLATION OF LIP CURBS AND THEIR EXTENTS TO BE DETERMINED BY THE CONTRACT ADMINISTRATOR.
 6. LIGHT STANDARDS, HYDRO POLES AND ANCHORS MAY REQUIRE TEMPORARY SUPPORT/REMOVAL OR REPLACEMENT AT THE CONTRACTOR'S EXPENSE.
 7. ISOLATE ALL POLES, BASES AND PILES WITHIN ALLEY RIGHT OF WAY (SD-228C).
 8. AVOID DAMAGE TO EXISTING TREES WITHIN THE LIMITS OF CONSTRUCTION.

PROPERTY LIMITS DELINEATION
DELINEATION OF PROPERTY LIMITS AS SHOWN ON THIS DWG DOES NOT REPRESENT A "LEGAL SURVEY". KGS GROUP MAKES NO REPRESENTATION OR WARRANTY AS TO THE ACCURACY OF PROPERTY LIMITS DELINEATED ON THIS DWG, NOR ON THE DIMENSIONAL ACCURACY OF DWG FEATURES RELATIVE TO THOSE PROPERTY LIMITS.

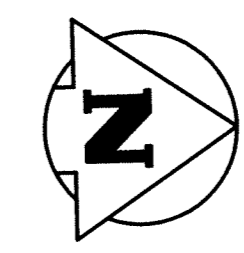

SARGENT AVE

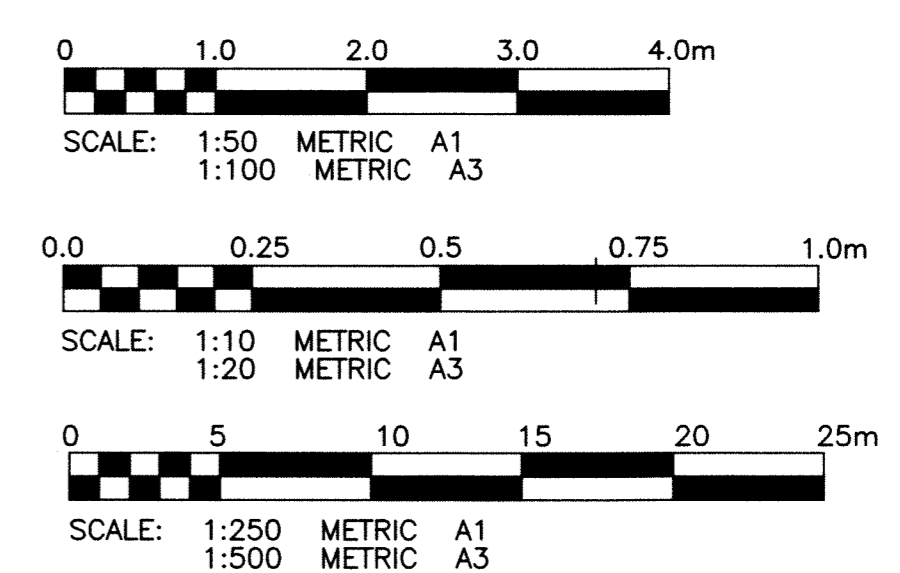

WARNING

1. NOTIFY THE GAS COMPANY OF THE PROPOSED LOCATION OF EXCAVATION.
2. TAKE PRECAUTION TO AVOID DAMAGE TO GAS COMPANY INSTALLATIONS.
3. SEE PROVINCIAL REGULATION 210/72 FOR DETAILS.

METRIC
WHOLE NUMBERS INDICATE MILLIMETRES
DECIMALIZED NUMBERS INDICATE METRES

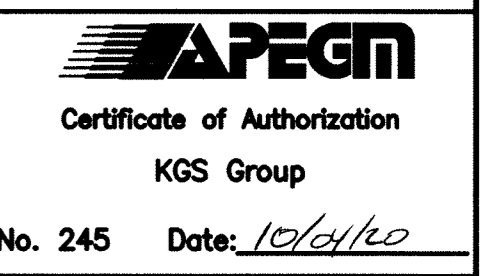

P:\Projects\2009\09-0107-20\DocControl\Tobias\dwg\09-0107-20_0003-REV 0.dwg - Tab: 03 Plotted By: DBoishele 04/20/2010 [Tue 3:53pm]

300 L.D.S.	LAND DRAINAGE SEWER	300 L.D.S.	+	TEST HOLE	
250 W.W.S.	WASTE WATER SEWER	250 W.W.S.	-	GUY WIRE	
	GAS		•••	LIGHT STANDARD	
	HYDRO		—	BACK OF CURB	
	M.T.S.		—	CONCRETE	
150 WM	WATERMAIN	150 WM	—	ASPHALT	
+	HYDRANT		+	SIDEWALK	
+	VALVE		+	RAMP CURB	
○	MANHOLE		+	PROPERTY LINE	
□	CATCH BASIN		+	SURVEY BAR	
▽	CURB INLET		+	GEODETIC BENCHMARK	
•	POLES I-MIS	231.334	+	ELEVATION	
•	POLES H-HYDRO		+		
EXISTING	LEGEND-PLAN	PROPOSED	EXISTING	LEGEND-PLAN	PROPOSED

LOCATION APPROVED UNDERGROUND STRUCTURES

SUPV. U/G STRUCTURES COMMITTEE DATE

NOTE:
LOCATION OF UNDERGROUND STRUCTURES AS SHOWN ARE BASED ON THE BEST INFORMATION AVAILABLE BUT NO GUARANTEE IS GIVEN THAT ALL EXISTING UTILITIES ARE SHOWN OR THAT THE GIVEN LOCATIONS ARE EXACT. CONFIRMATION OF EXISTENCE AND EXACT LOCATION OF ALL SERVICES MUST BE OBTAINED FROM THE INDIVIDUAL UTILITIES BEFORE PROCEEDING WITH CONSTRUCTION.

B.M. 36-061	N.W. COR. SARGENT AVE. & GARFIELD ST. N.
ELEV. 233.373	T.B.L. IN S. CONC. FOUNDATION OF SARGENT AVE. MENONITE CHURCH, 0.5m W. & 1.7m BELOW BRICK OF S.E. COR. OF BLDG.
NO.	REVISIONS
0	ISSUED FOR TENDER
	DATE
	BY

KGS GROUP CONSULTING ENGINEERS	
DESIGNED BY	RBO
CHECKED BY	CR
DRAWN BY	GEL
APPROVED BY	MA
HOR. SCALE:	1:250
VERTICAL:	1:50
RELEASED FOR CONSTRUCTION:	
DATE	10/02/03

ENGINEER'S SEAL

PROVINCE OF MANITOBA
REGISTERED PROFESSIONAL ENGINEER
R/B OFFMAN
Member 2474

CONSULTANT DRAWING NO.
09-0107-20_003

THE CITY OF WINNIPEG PUBLIC WORKS DEPARTMENT TRANSPORTATION ENGINEERING DIVISION

PROJECT TITLE: 2010 ALLEY & LOCAL STREET RENEWALS

SHEET OF 03 OF 18

COMPUTER FILE NAME: DOWNING-DOMINION-PLAN

CITY DRAWING NUMBER: 0003

DOWNING ST./DOMINION ST. ALLEY
ELLICE AVE. TO SARGENT AVE.
STA. 3+62.5 TO SARGENT AVE.