

**ALLEY PAVEMENT PROFILE**  
SCALE: 1:250 HOR  
1:10 VER

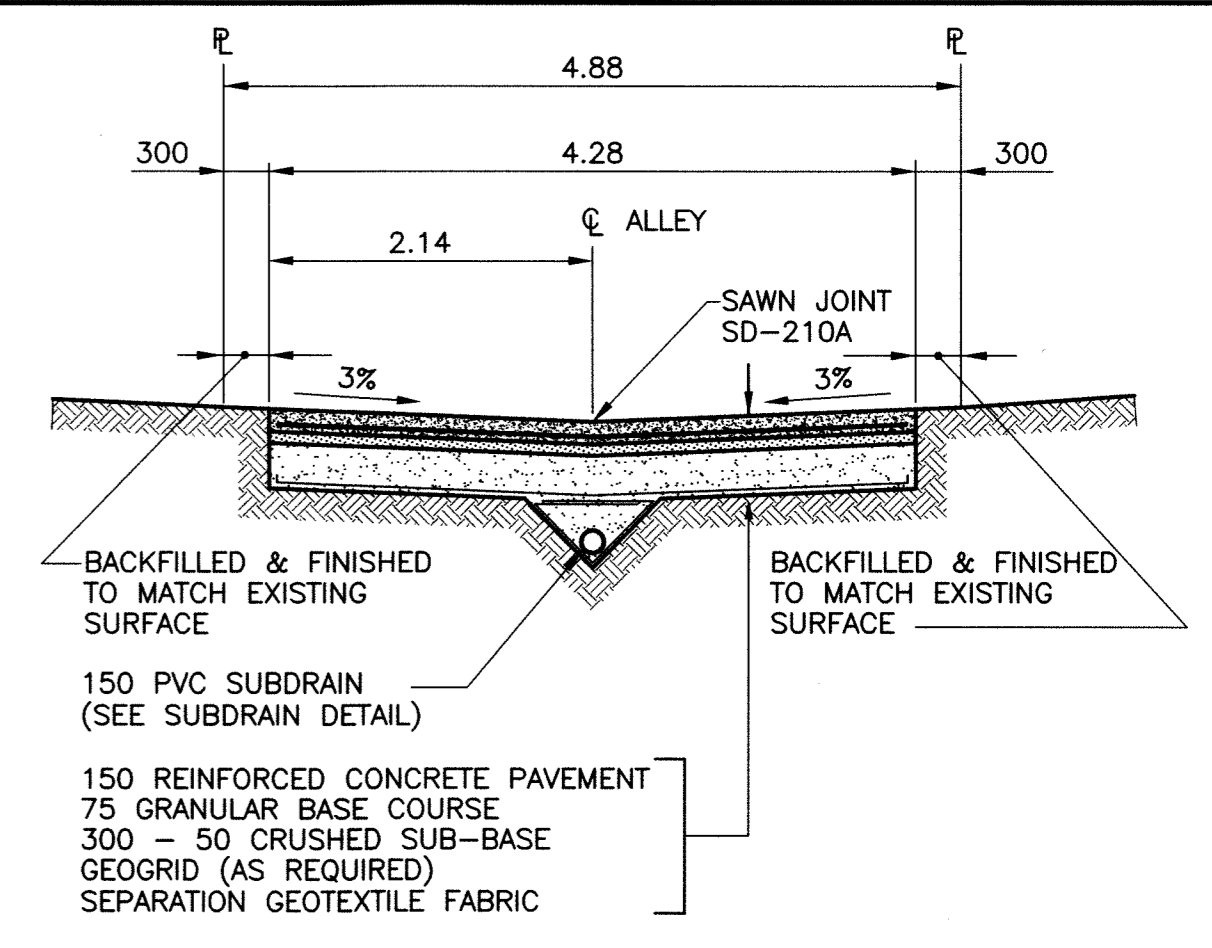

**TYPICAL CROSS SECTION**  
SCALE: 1:50

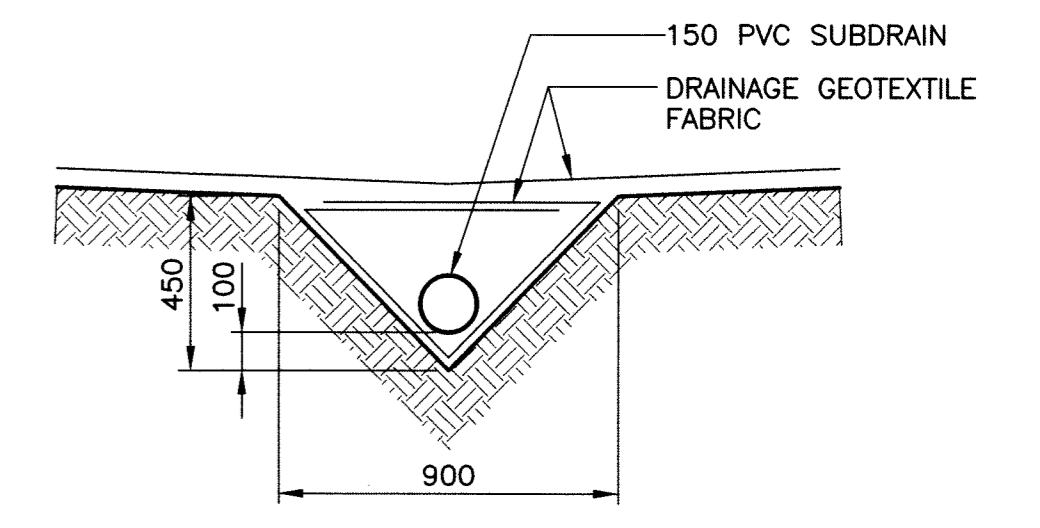

**SUBDRAIN DETAIL**  
SCALE: 1:20

- NOTE:**
1. STATION CHAINAGE IS BASED ON CENTERLINE OF ALLEY RIGHT OF WAY.
  2. ADJUST MH AND CB RIMS TO NEW GRADES.
  3. PLUG SUBDRAINS AT TERMINAL ENDS.
  4. REGRADE EXISTING PRIVATE SIDEWALKS AS REQUIRED.
  5. INSTALLATION OF LIP CURBS AND THEIR EXTENTS TO BE DETERMINED BY THE CONTRACT ADMINISTRATOR.
  6. LIGHT STANDARDS, HYDRO POLES AND ANCHORS MAY REQUIRE TEMPORARY SUPPORT/REMOVAL OR REPLACEMENT AT THE CONTRACTOR'S EXPENSE.
  7. ISOLATE ALL POLES, BASES AND PILES WITHIN ALLEY RIGHT OF WAY (SD-228C).
  8. AVOID DAMAGE TO EXISTING TREES WITHIN THE LIMITS OF CONSTRUCTION.

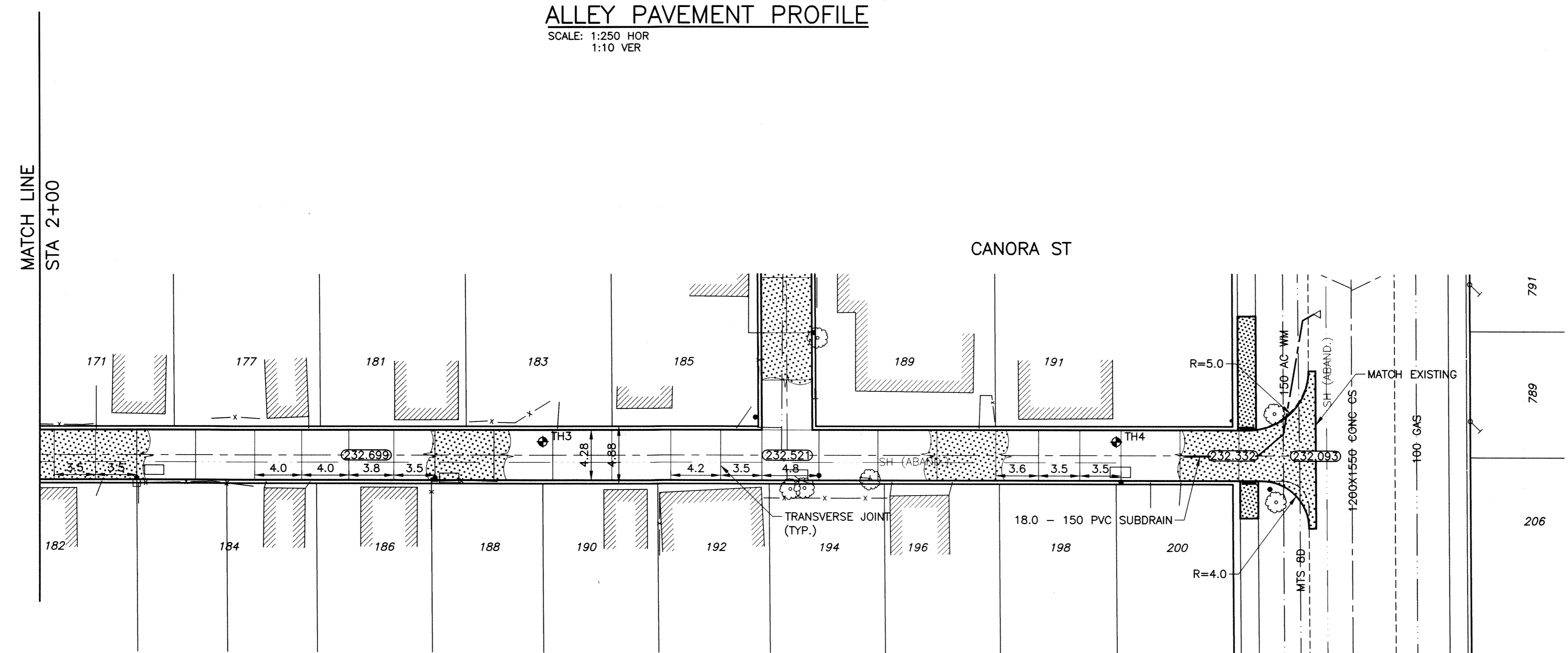

**ALLEY PAVEMENT PLAN**  
SCALE: 1:250 HOR

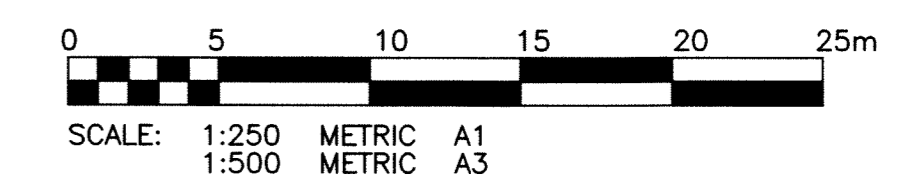
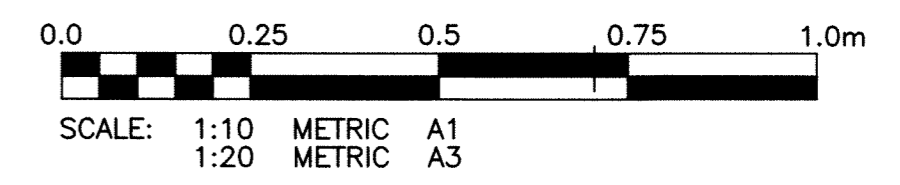
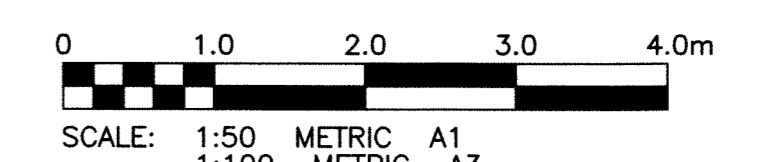
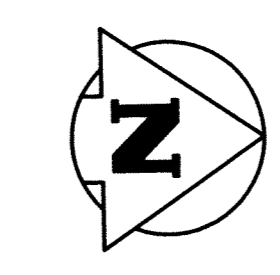

**PROPERTY LIMITS DELINEATION**

DELINEATION OF PROPERTY LIMITS AS SHOWN ON THIS DWG DOES NOT REPRESENT A "LEGAL SURVEY". KGS GROUP MAKES NO REPRESENTATION OR WARRANTY AS TO THE ACCURACY OF PROPERTY LIMITS DELINEATED ON THIS DWG, NOR ON THE DIMENSIONAL ACCURACY OF DWG FEATURES RELATIVE TO THOSE PROPERTY LIMITS.

**WARNING**

1. NOTIFY THE GAS COMPANY OF THE PROPOSED LOCATION OF EXCAVATION.
2. TAKE PRECAUTION TO AVOID DAMAGE TO GAS COMPANY INSTALLATIONS.
3. SEE PROVINCIAL REGULATION 210/72 FOR DETAILS.

**METRIC**

WHOLE NUMBERS INDICATE MILLIMETRES  
DECIMALIZED NUMBERS INDICATE METRES

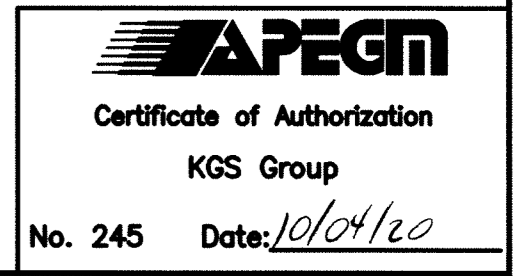

F:\Projects\2009\09-0107-20\DocControl\Released\DWG\09-09-0107-20\_0011-REV 0.dwg - Tab: 11 Plotted By: Dorothea 04/20/2010 [True 3x7mm]

300 L.D.S.	LAND DRAINAGE SEWER	300 L.D.S.	TEST HOLE			
250 WWS	WASTE WATER SEWER	250 WWS	GUY WIRE			
	GAS		LIGHT STANDARD			
	HYDRO		BACK OF CURB			
	M.T.S.		CONCRETE			
	WATERMAIN	150 WM	ASPHALT			
150 WM	HYDRANT		SIDEWALK			
	VALVE		RAMP CURB			
	MANHOLE		PROPERTY LINE			
	CATCH BASIN		SURVEY BAR			
	CURB INLET		GEODETIC BENCHMARK			
	POLES	M.T.S. HYDRO	ELEVATION			
EXISTING	LEGEND-PLAN	PROPOSED	EXISTING	LEGEND-PLAN	PROPOSED	EXISTING
				LEGEND-PROFILE	PROPOSED	

**LOCATION APPROVED UNDERGROUND STRUCTURES**

SUPV. U/G STRUCTURES COMMITTEE DATE

**NOTE:**  
LOCATION OF UNDERGROUND STRUCTURES AS SHOWN ARE BASED ON THE BEST INFORMATION AVAILABLE BUT NO GUARANTEE IS GIVEN THAT ALL EXISTING UTILITIES ARE SHOWN OR THAT THE GIVEN LOCATIONS ARE EXACT. CONFIRMATION OF EXISTENCE AND EXACT LOCATION OF ALL SERVICES MUST BE OBTAINED FROM THE INDIVIDUAL UTILITIES BEFORE PROCEEDING WITH CONSTRUCTION.

B.M. 37-057  
ELEV. 232.946

N.W. COR. WESTMINSTER AVE. & ETHELBERG ST., TELY. IN MOST ELY. CONC. FOUNDATION NO. 1160 ETHELBERG ST. (ST. MARGARET'S ANGLICAN CHURCH), 8m S. & 0.1m BELOW BRICK OF N.E. COR. OF CHURCH

**KGS GROUP**  
CONSULTING ENGINEERS

DESIGNED BY: RBO  
CHECKED BY: CR

DRAWN BY: GEL  
APPROVED BY: RBO

HOR. SCALE: 1:250  
VERTICAL: 1:50

RELEASED FOR CONSTRUCTION: 10/02/03

ENGINEER'S SEAL

PROVINCE OF MANITOBA  
REGISTERED PROFESSIONAL ENGINEER  
R.B. OFFMAN  
Member  
2474

CONSULTANT DRAWING NO.  
09-0107-20\_C11

**THE CITY OF WINNIPEG**  
PUBLIC WORKS DEPARTMENT  
TRANSPORTATION ENGINEERING DIVISION

PROJECT TITLE  
2010 ALLEY & LOCAL STREET RENEWALS

SHEET 11 OF 18

COMPUTER FILE NAME  
CANORA-CHESTNUT-PLAN

CITY DRAWING NUMBER  
0011

CANORA ST./CHESTNUT ST. ALLEY  
WESTMINSTER AVE. TO PRESTON AVE.  
STA. 2+00 TO PRESTON AVE.