

FIELD SPlice FOR G1 AND G2
SCALE 1:10

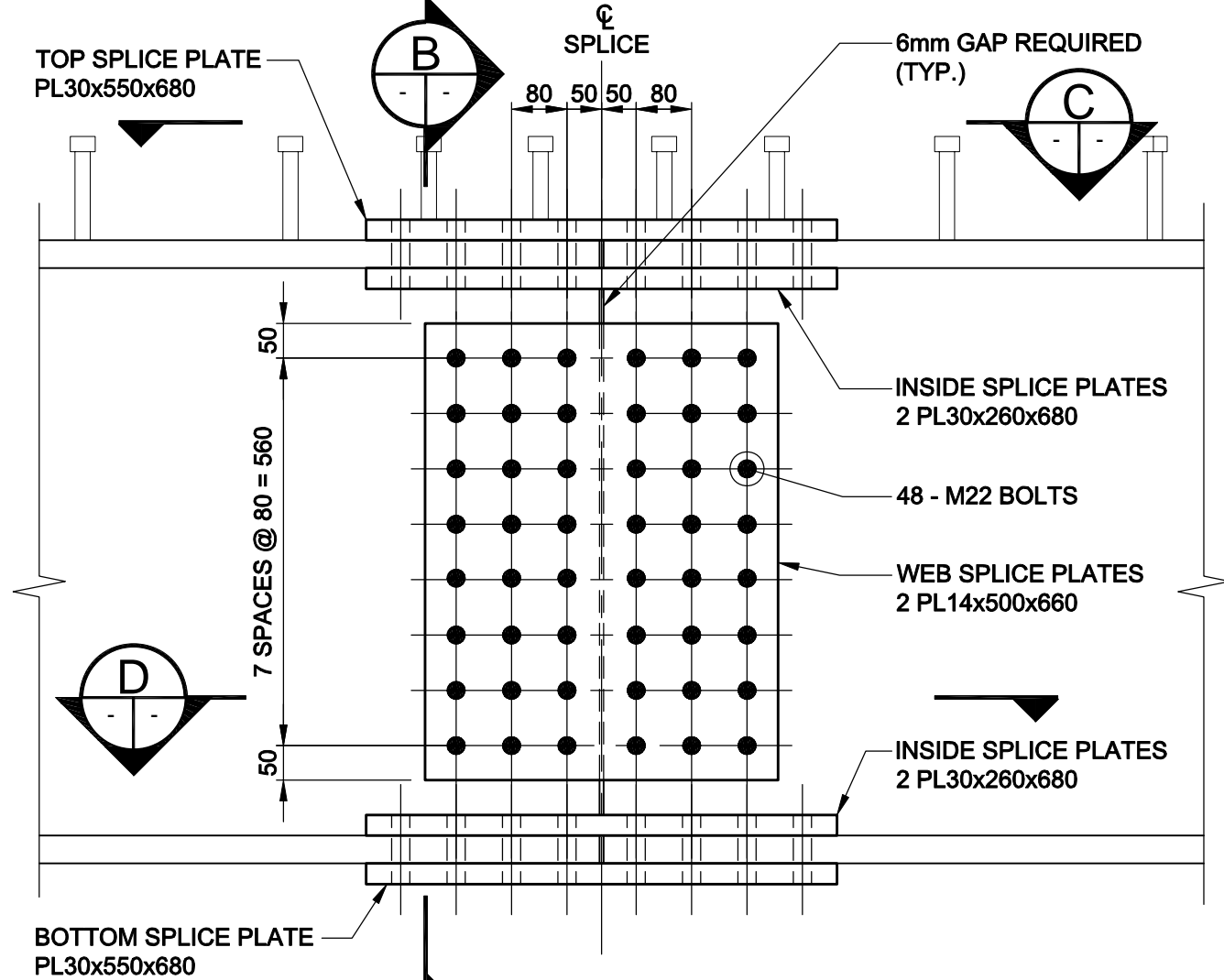

FIELD SPlice FOR G3 AND G4
SCALE 1:10

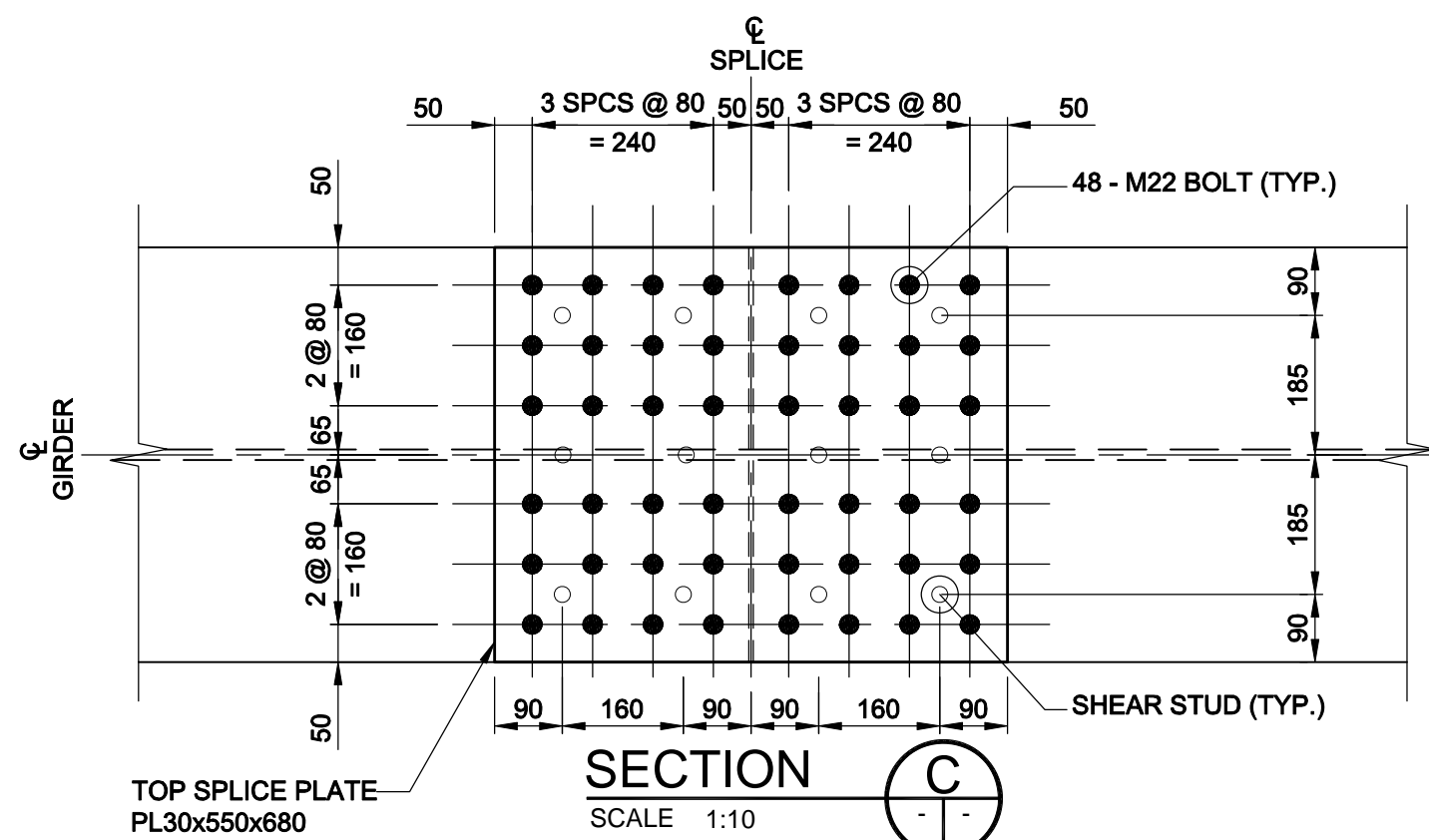

SECTION C
SCALE 1:10

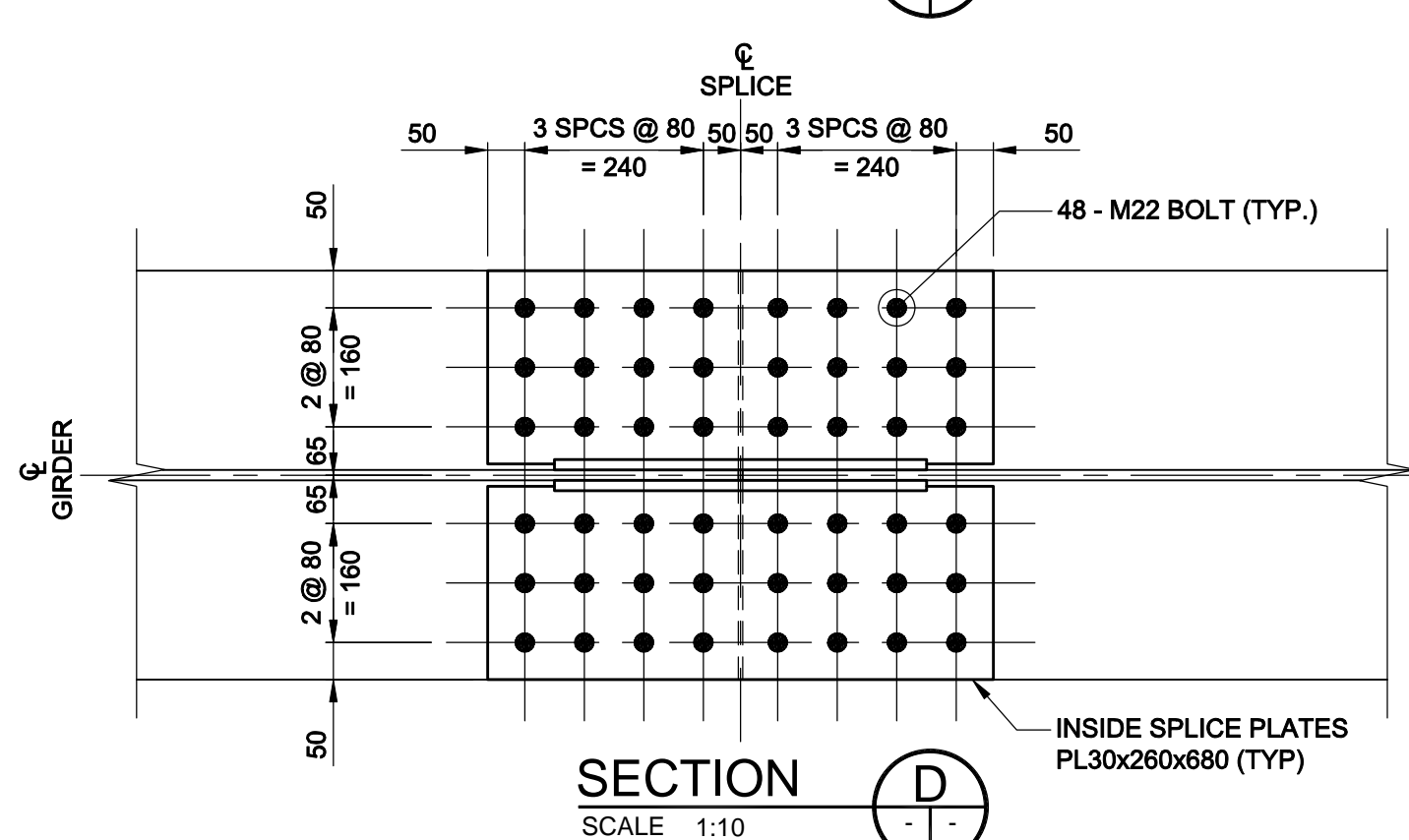

SECTION D
SCALE 1:10

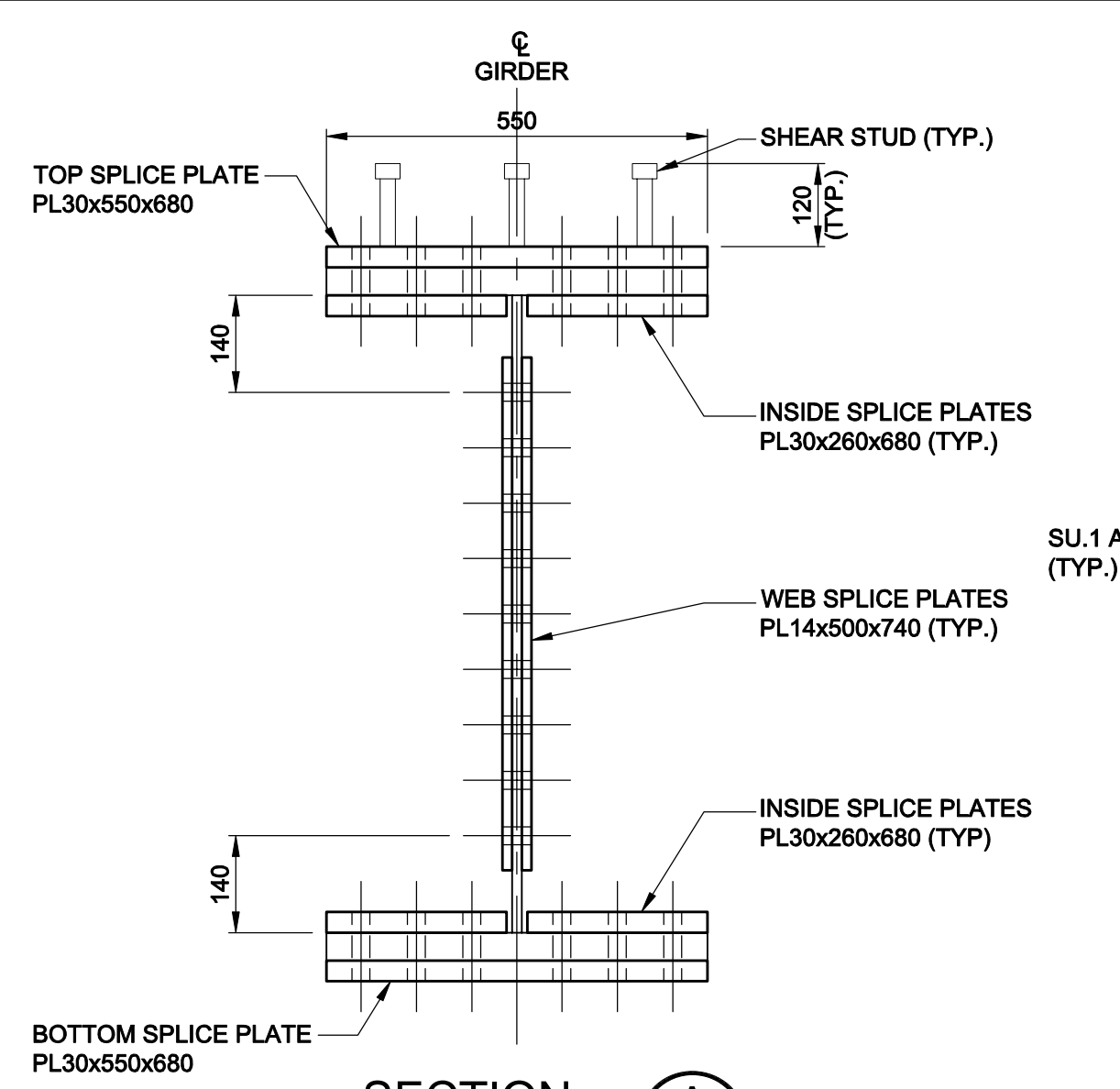

SECTION A
SCALE 1:10

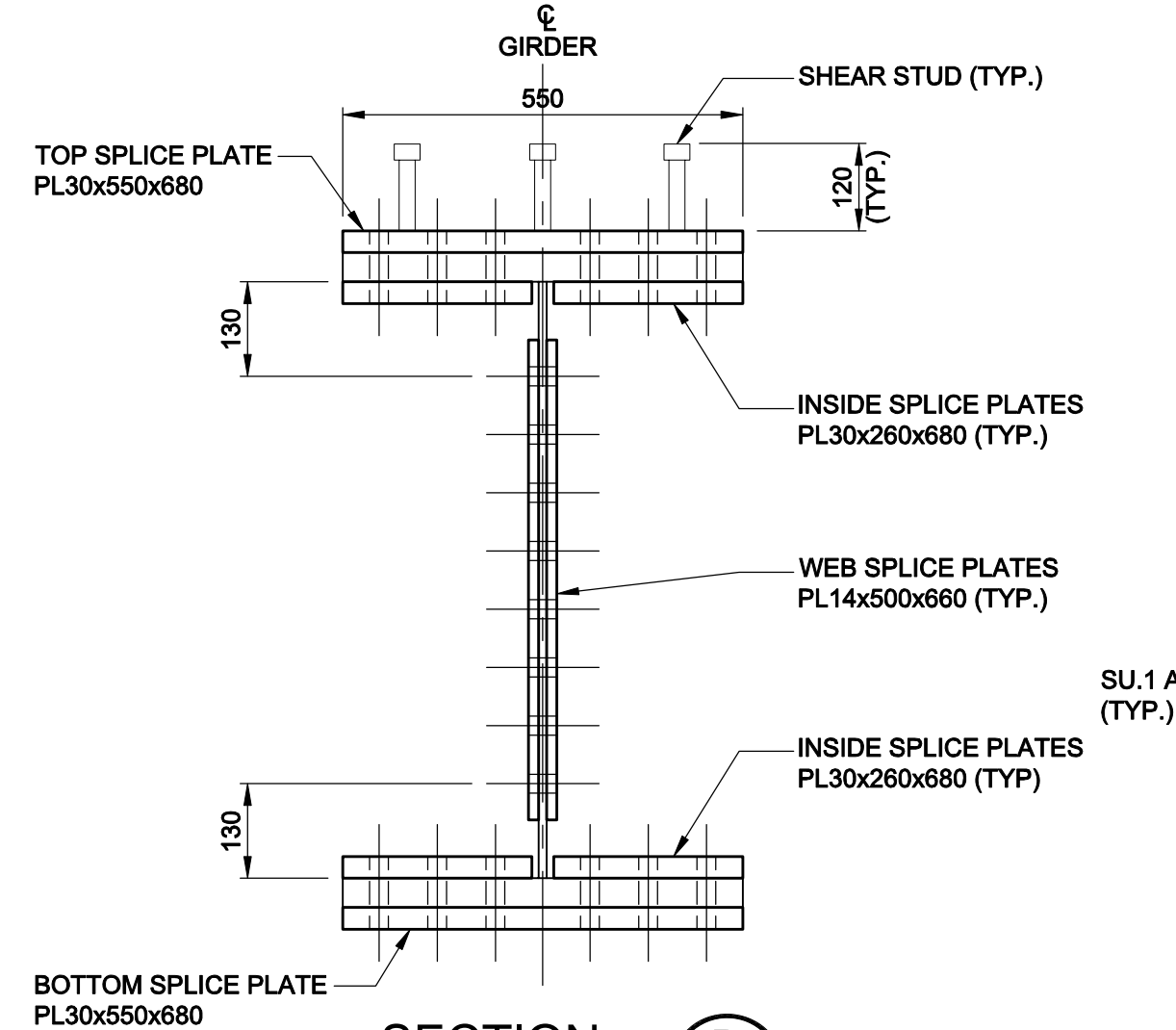

SECTION B
SCALE 1:10

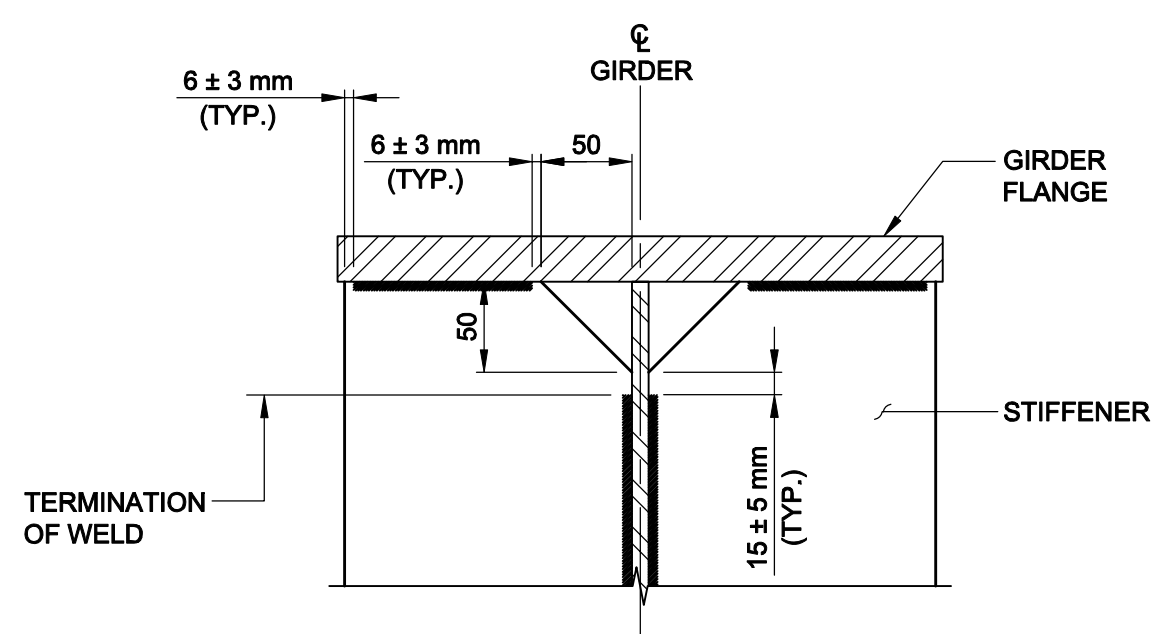

WELD LIMIT DETAIL
SCALE 1:5 (TYP ALL STIFFENERS)

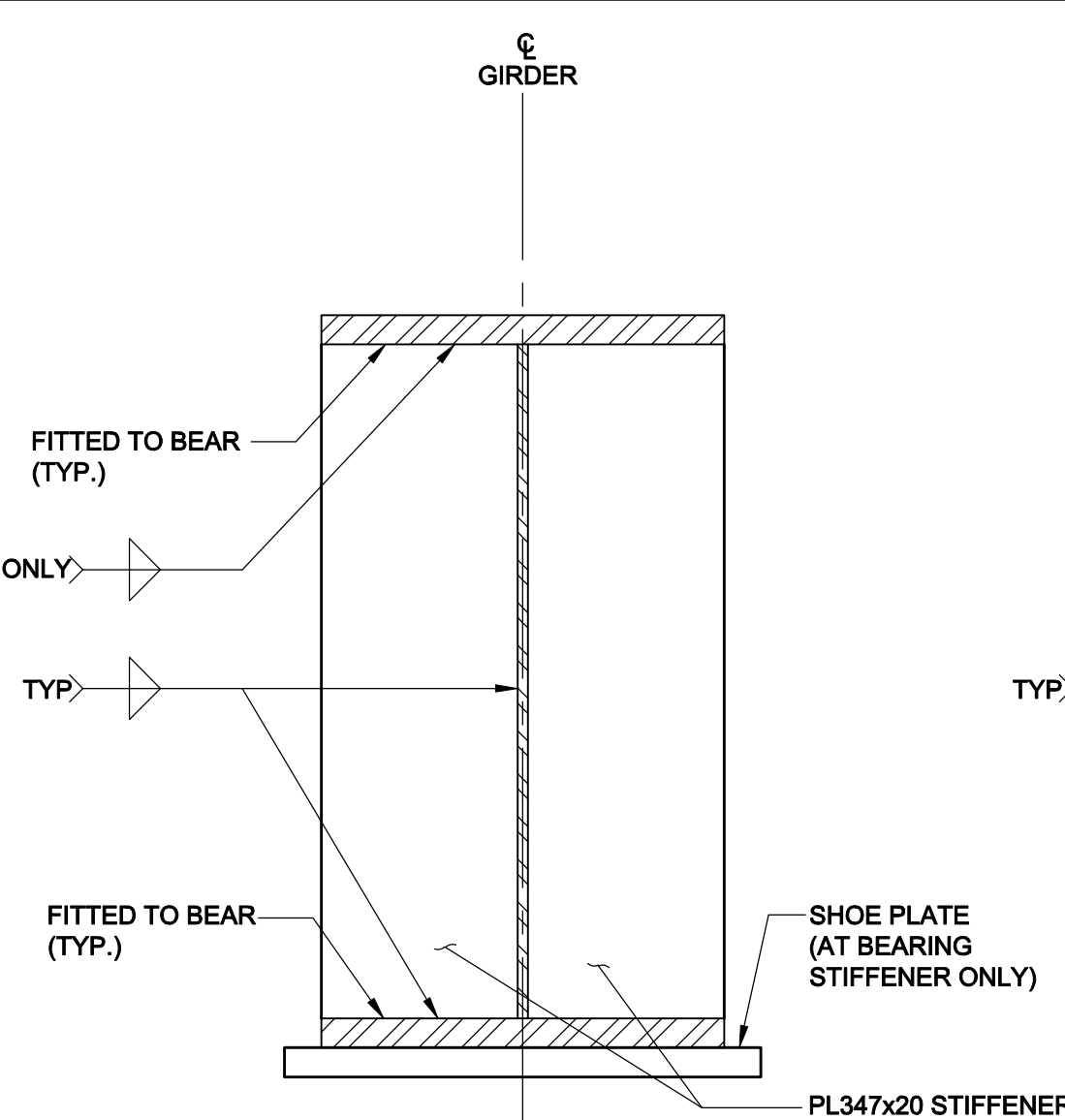

BEARING / END DIAPHRAGM STIFFENER G1 AND G2
NOTE: GIRDER ON SKEW

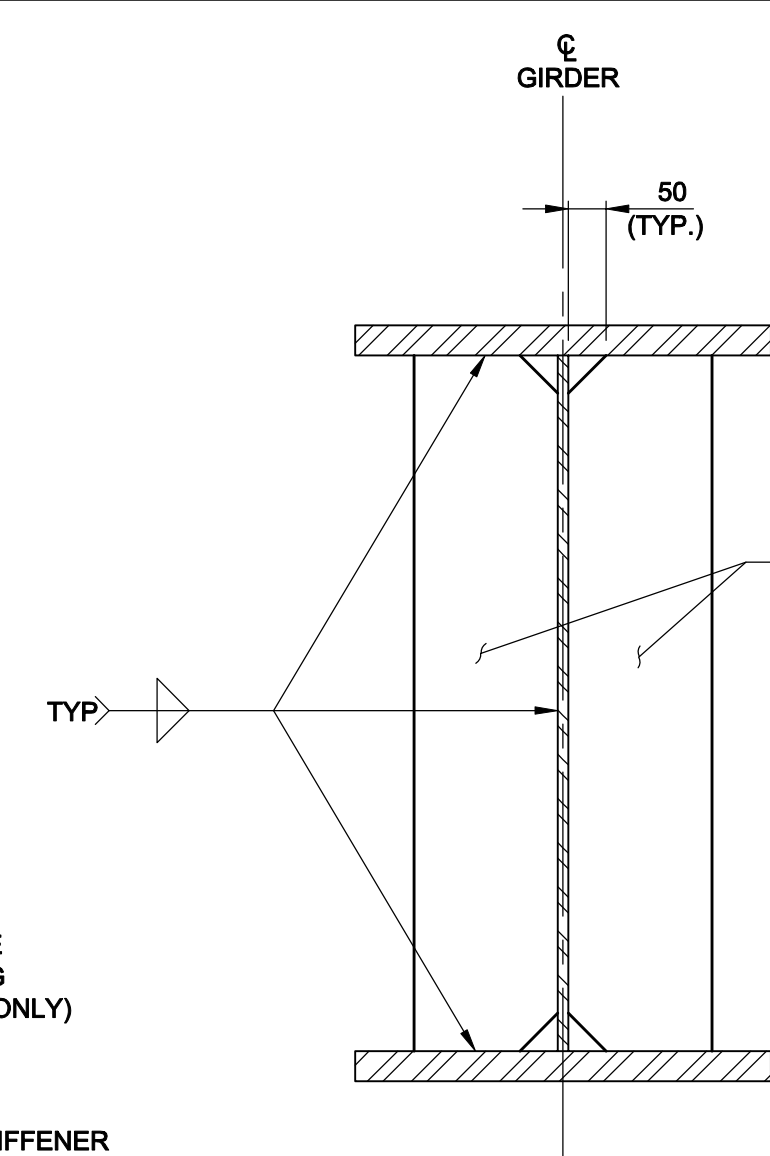

INTERMEDIATE STIFFENER G1 AND G2
NOTE: GIRDER ON SQUARE

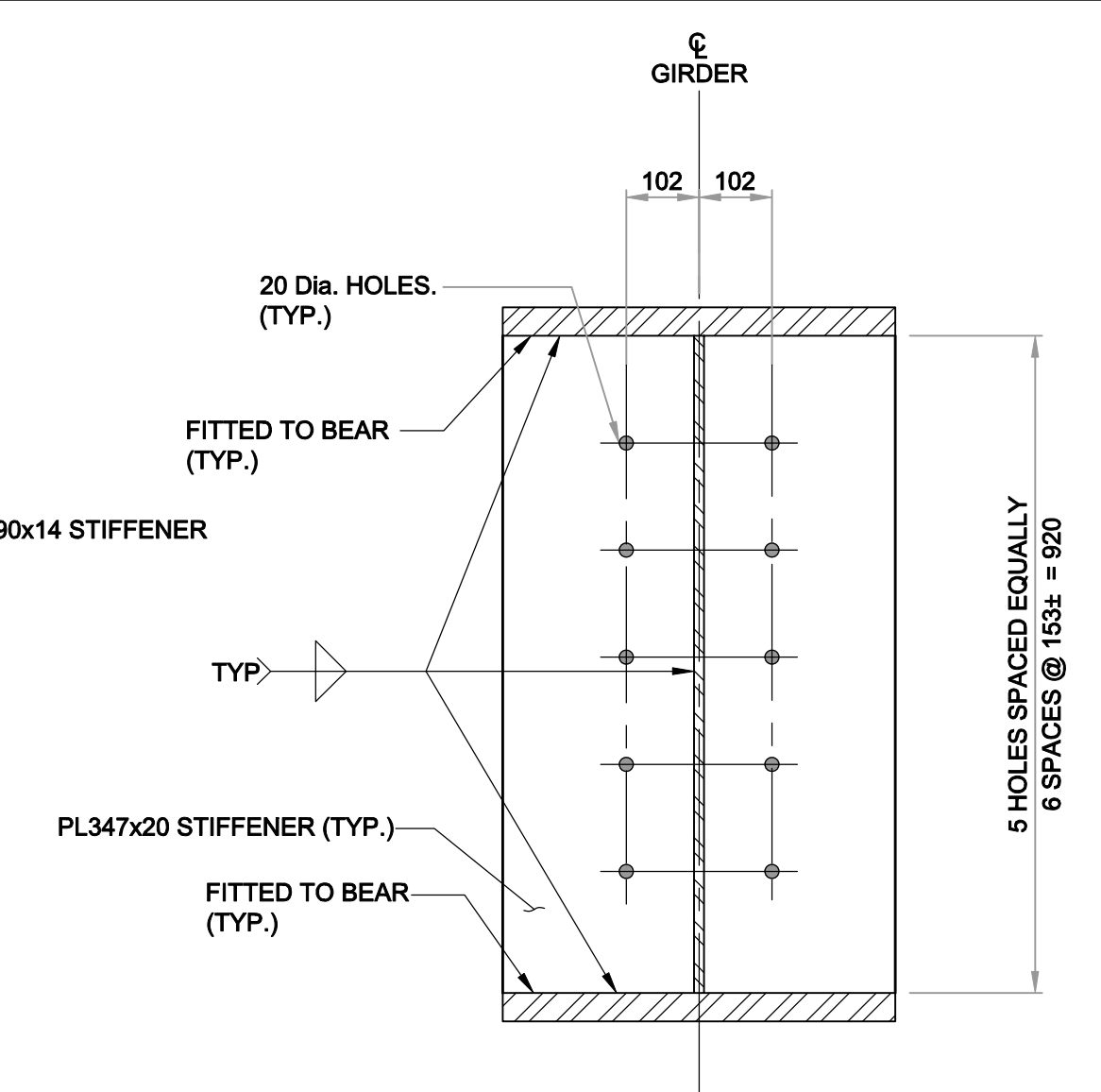

JACKING / RETAINER STIFFENER G1 AND G2
NOTE: GIRDER ON SKEW

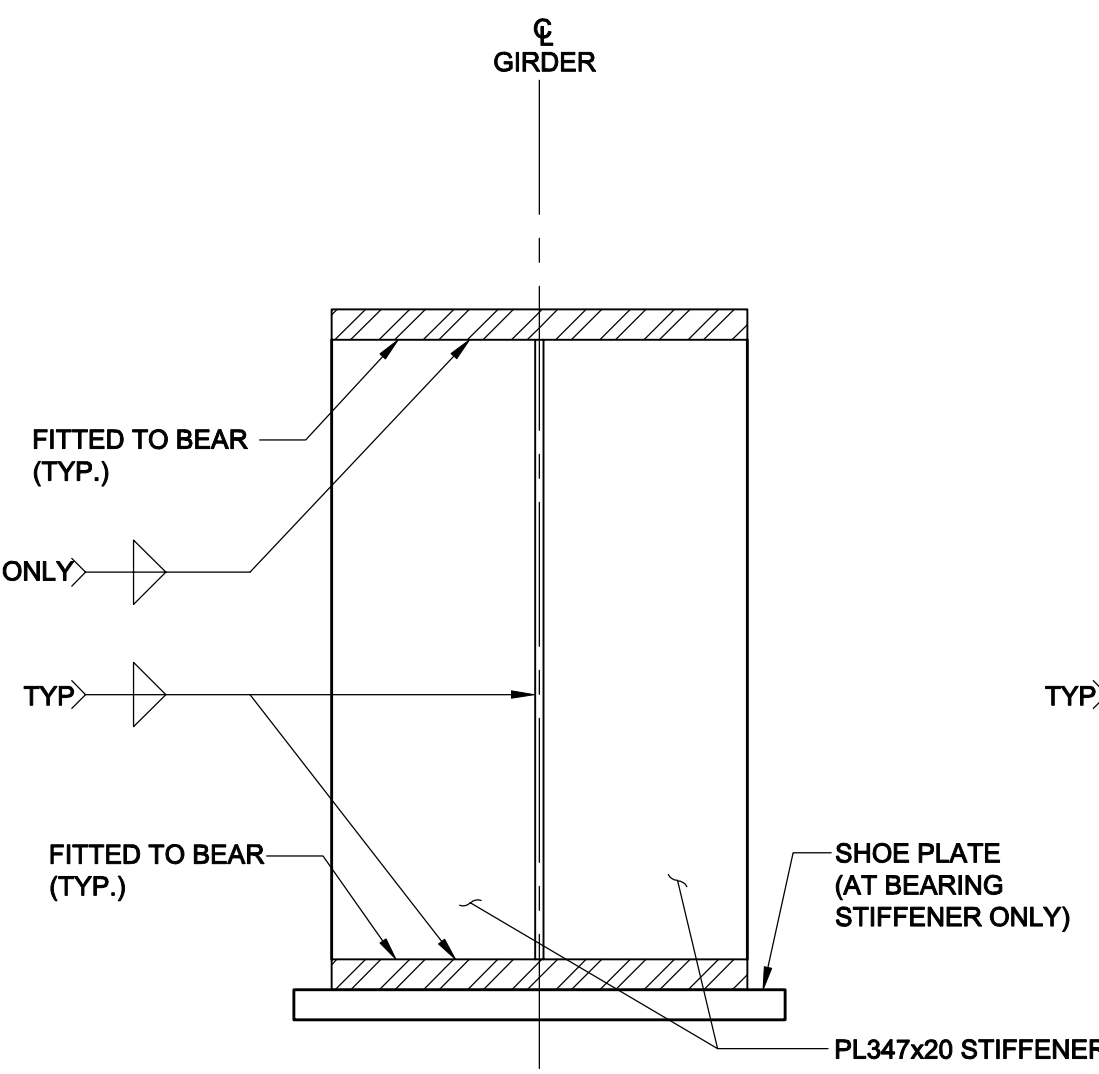

BEARING / END DIAPHRAGM STIFFENER G3 AND G4
NOTE: GIRDER ON SKEW

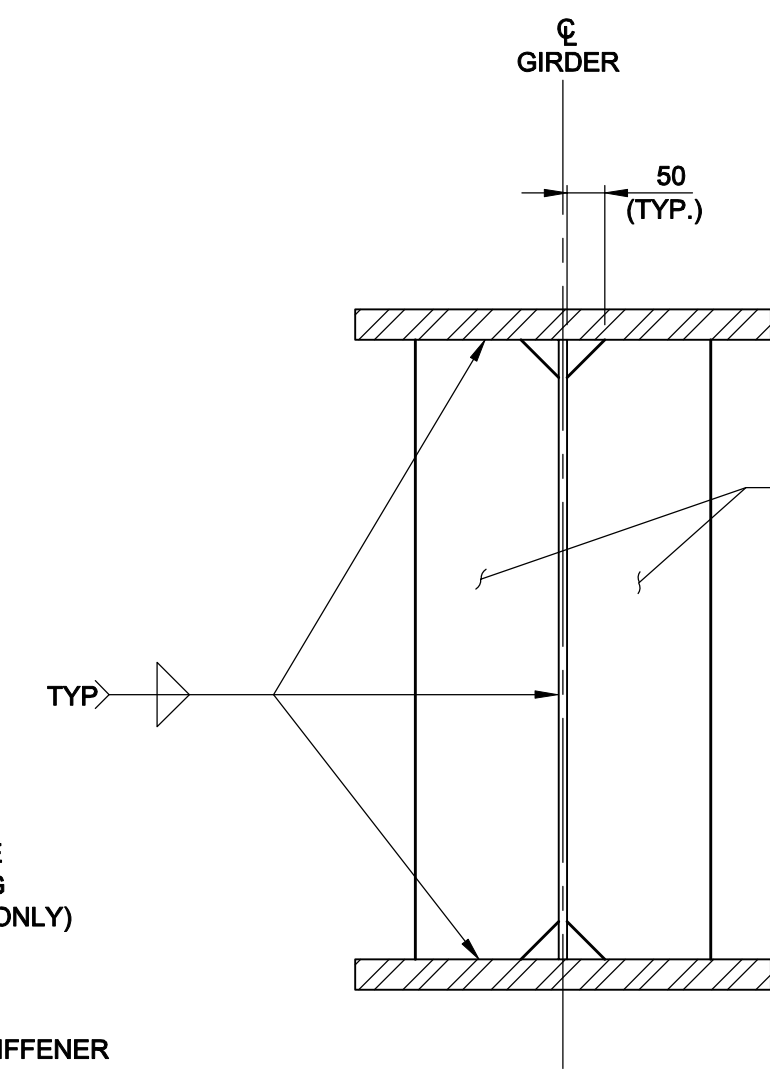

INTERMEDIATE STIFFENER G3 AND G4
NOTE: GIRDER ON SQUARE

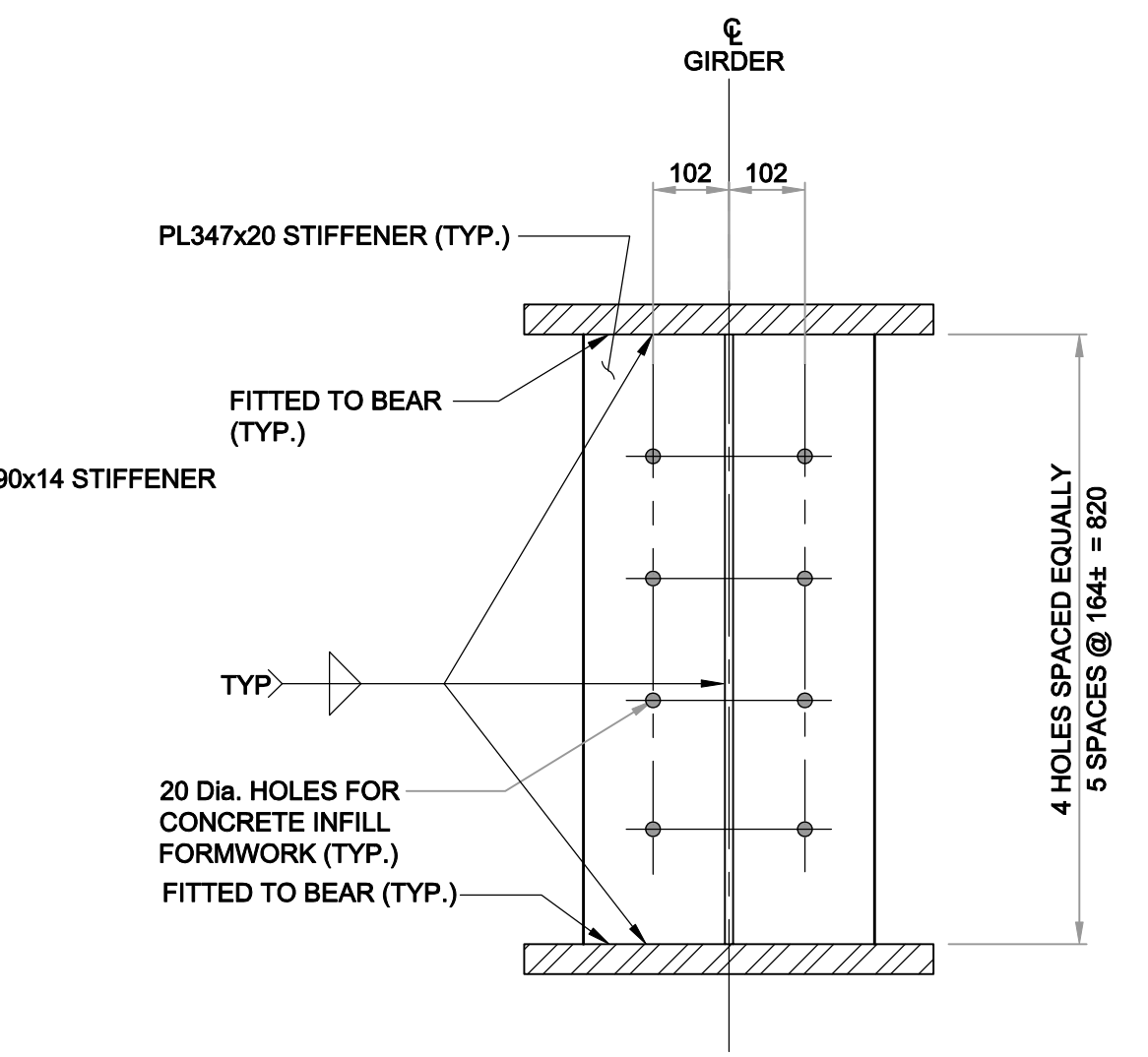

JACKING / RETAINER STIFFENER G3 AND G4
NOTE: GIRDER ON SKEW

TRANSVERSE STIFFENER TYPES
SCALE 1:10

NOTE: SECTIONS SHOWN PERPENDICULAR TO GIRDER WEB
SHEAR STUDS NOT SHOWN FOR CLARITY

NOTE: SHEAR STUDS NOT SHOWN ON GIRDER FOR CLARITY FOR SECTIONS C AND D.



LOCATION UNDERGROUND APPROVED STRUCTURES
SUPV. U/G STRUCTURES COMMITTEE DATE
NOTE: LOCATION OF UNDERGROUND STRUCTURES AS SHOWN ARE BASED ON THE BEST INFORMATION AVAILABLE BUT NO GUARANTEE IS GIVEN THAT ALL EXISTING UTILITIES ARE SHOWN OR THAT THE GIVEN LOCATIONS ARE EXACT. CONFIRMATION OF EXISTENCE AND EXACT LOCATION OF ALL SERVICES MUST BE OBTAINED FROM THE INDIVIDUAL UTILITIES BEFORE PROCEEDING WITH CONSTRUCTION.

NO.	REVISIONS	DATE	BY	DATE
1	ISSUED FOR TENDER	10/05/14	DPK	

DESIGNED BY	JCL
DRAWN BY	MJB
CHECKED BY	SSR
APPROVED BY	DPK
HOR. SCALE	AS SHOWN
VERTICAL	AS SHOWN

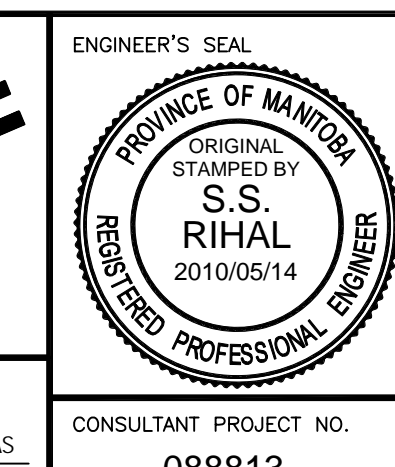
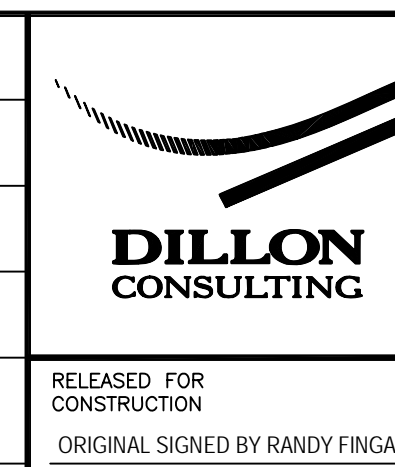

THE CITY OF WINNIPEG TRANSIT DEPARTMENT

SOUTHWEST RAPID TRANSIT CORRIDOR - STAGE 1
OSBORNE STATION & ASSOCIATED WORKS

STEEL GIRDETS - DETAILS

CITY DRAWING NUMBER: B237-10-35
SHEET 35 OF 121
CONSULTANT DRAWING NUMBER: C5-S1120-T

- NOTES:**
- MINIMUM EDGE DISTANCE MUST BE MAINTAINED.
 - MINIMUM WELD SIZE, REFER TO SHEET # 31