

NOTE:

- GRID LINE 6x (EXISTING) and GRID LINE 8 (NEW ADDITION) ARE SHOWN ALIGNED ON THIS DRAWING. THESE GRIDLINES MIGHT NOT BE 100% ALIGNED. ALIGNMENT MUST BE VERIFIED ON SITE PRIOR TO START OF CONSTRUCTION. (SEE NOTE ON A11)
- GRID LINES 1 and 1x ALIGNMENT IS NECESSARY.

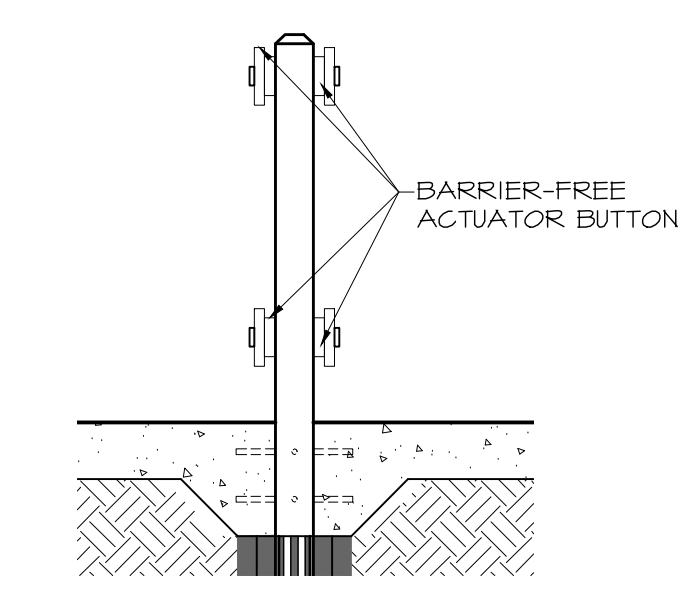

4 B.F. DOOR ACTUATOR SIDE ELEV
2.1 | 2.1 1:20

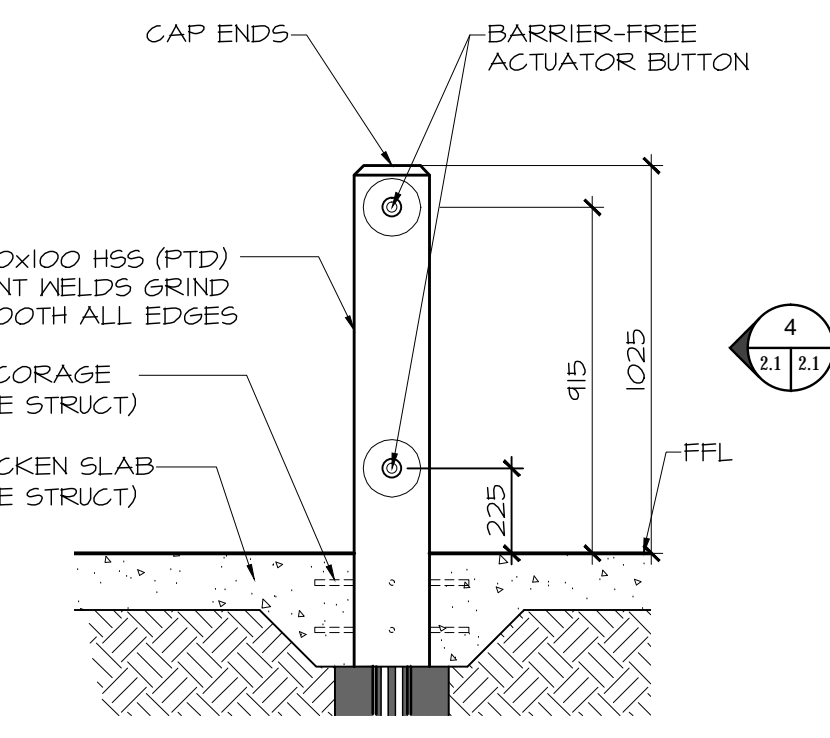

3 BARRIER-FREE DOOR ACTUATOR DETAIL
2.1 | 2.1 1:20

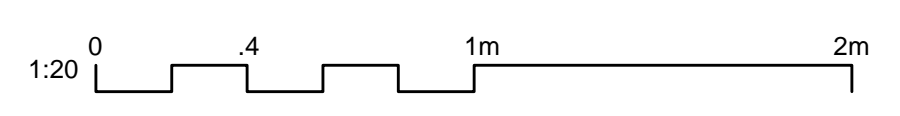

NOTES:

- DIMENSIONS SHOWN FOR EXISTING CONSTRUCTION ARE BASED ON INFORMATION AVAILABLE ON ORIGINAL REFERENCE DRAWINGS. AS-BUILT DIMENSIONS MAY VARY. INFORM THE CONTRACT ADMINISTRATOR OF ANY DISCREPANCY PRIOR TO CONSTRUCTION. (NOTES TYP TO ALL SHEETS)

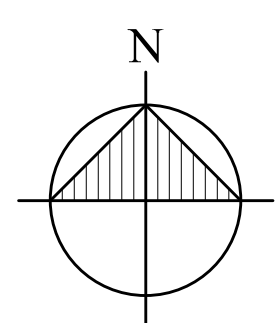

NO.	REVISION	DATE	BY
1	ISSUED W/ADDENDUM 3	2010.06.10	CAA
0	ISSUED FOR TENDER	2010.05.13	CAA

THIS DRAWING IS THE EXCLUSIVE PROPERTY OF THE ARCHITECT AND CAN BE REPRODUCED ONLY WITH THE PERMISSION OF THE ARCHITECT IN WHICH CASE THE REPRODUCTION MUST BEAR THE NAME OF THE ARCHITECT.

THIS DRAWING SHALL NOT BE SCALED. FOLLOW GIVEN DIMENSIONS ONLY.

THE CONTRACTOR SHALL SATISFY HIMSELF THAT ALL DIMENSIONS AND INFORMATION SHOWN ARE CORRECT.

PRIOR TO COMMENCEMENT OF WORK REPORT ANY DISCREPANCIES TO THE ARCHITECT.

VARIATIONS AND MODIFICATIONS TO WORK SHOWN WILL NOT BE ALLOWED WITHOUT WRITTEN PERMISSION OF THE ARCHITECT.

CONSULTANT

SEAL

ED CALNITSKY
REGISTERED ARCHITECT

CALNITSKY ASSOCIATES ARCHITECTS INC.
No. 152
REGISTERED ARCHITECTURAL CORPORATION

CALNITSKY ASSOCIATES ARCHITECTS INC.

ARCHITECTURE | INTERIOR DESIGN

124 Nassau Street North Winnipeg, Manitoba R3L 2H1
Tel: (204) 453-6441 Fax: (204) 453-3392
E-mail: caa@escape.ca

PROJECT TITLE

ADDITION & RENOVATION OF WINAKWA COMMUNITY CENTRE

980 WINAKWA RD, WINNIPEG

SHEET TITLE

MAIN FLOOR PLAN

DRAWN BY	SCALE	SHEET NUMBER
CS	AS SHOWN	A2.1
CHECKED BY	DATE	
CS, BM	2010.05.13	
PROJECT NO.	REV. DATE	REV. NO.
09-012		R-1