

Drawing Title:

# WASTE RECEPTACLE EXPANDED METAL BASKET

Drawing No:

**SCD-106**

**Product # 52501051**

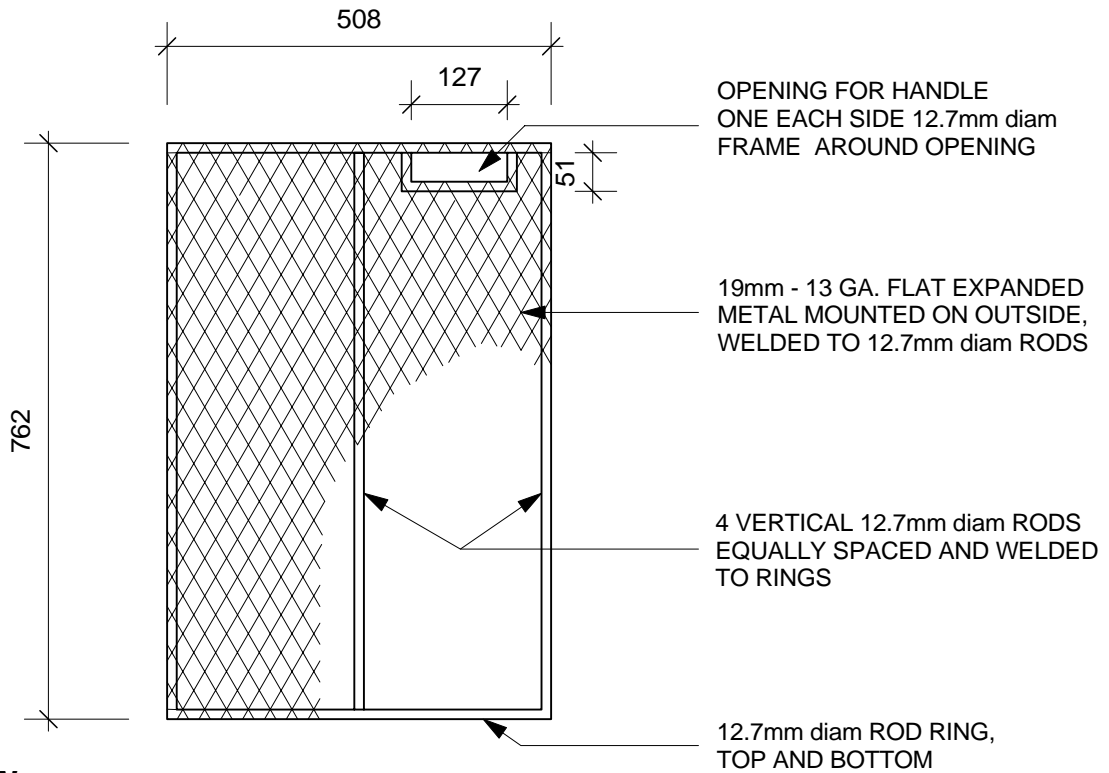

**SIDE VIEW**

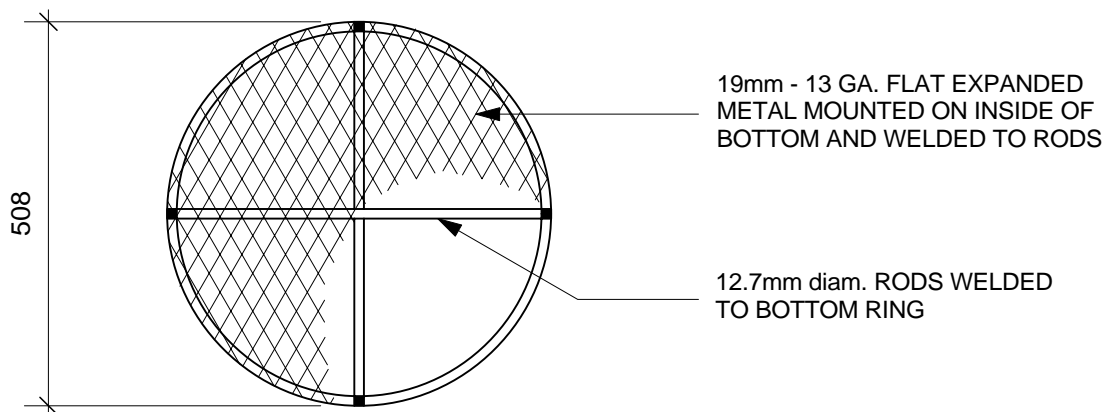

**BOTTOM VIEW**

**NOTE:**

APPLY ONE COAT OF METAL  
PRIMER AND ONE COAT OF  
ALUMINUM PAINT.

DIMENSIONS SHOWN ARE IN MILLIMETRES UNLESS OTHERWISE SPECIFIED

DATE: July 1, 2004  
SCALE: N.T.S.  
DRAWN BY: ST

The City of Winnipeg  
Planning, Property and Development Department  
Planning and Land Use Division  
Unit 15 - 30 Fort Street, Winnipeg, MB, R3C 4X5

