

NOTES:

1. LOCATION OF PATHWAY, DITCHES, BOULEVARD, AND CULVERTS TO BE FINALIZED IN THE FIELD BY CONTRACT ADMINISTRATOR
2. CONTRACTOR TO TAKE PRECAUTIONARY STEPS TO AVOID DAMAGE FROM CONSTRUCTION ACTIVITIES TO TREES WITHIN THE LIMITS OF CONSTRUCTION
3. REGRADEING OF EXISTING DITCHES TO BE DIRECTED BY CONTRACT ADMINISTRATOR
4. RENEWAL OF EXISTING APPROACHES, PAVEMENT, CURBS, SIDEWALKS, CULVERTS, DITCHES AND BOULEVARD TO BE DIRECTED BY CONTRACT ADMINISTRATOR

**CHAINAGE ALONG
CENTER OF PATH
DUGALD ROAD**

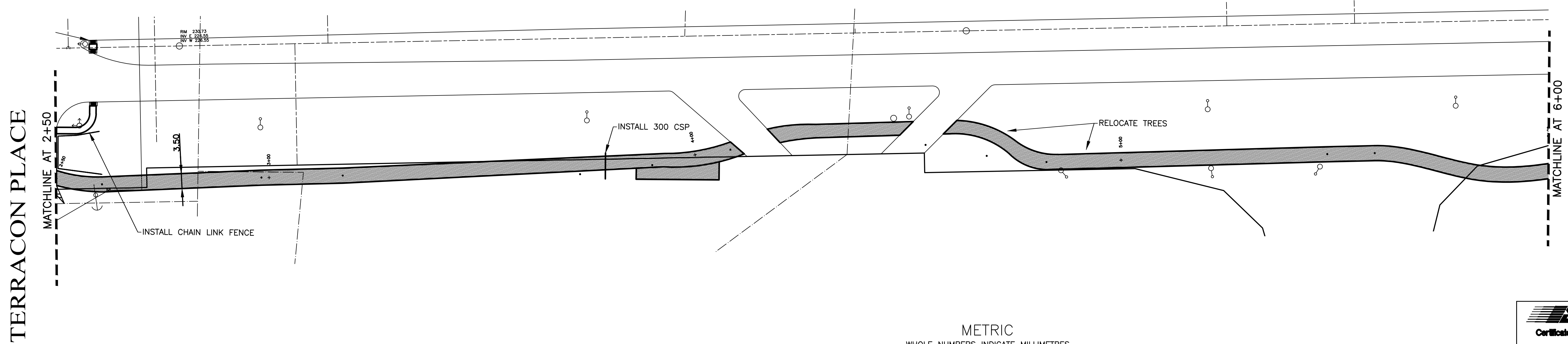
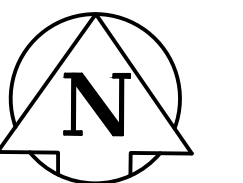
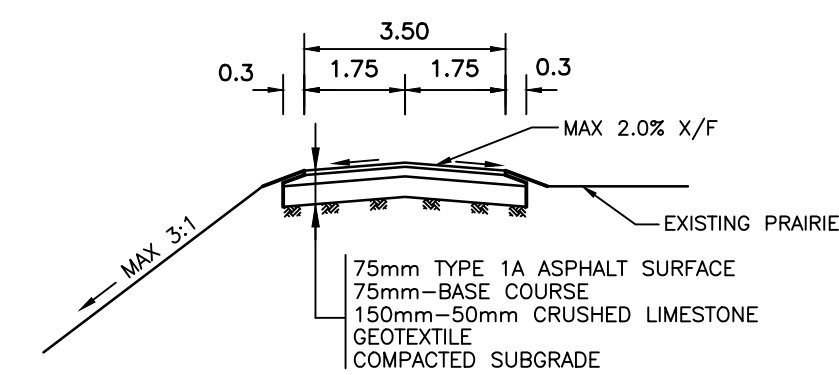

METRIC
WHOLE NUMBERS INDICATE MILLIMETRES
DECIMALIZED NUMBERS INDICATE METRES



---	WATERMAIN	---	HYDRO	---	CENTER LINE	---
○	HYDRANT	+	M.T.S.	---	NORTH GUTTER LINE	---
○	VALVE	○	CONCRETE	---	SOUTH GUTTER LINE	---
---	LAND DRAINAGE SEWER	---	ASPHALT	---	WATERMAIN	---
---	WASTE WATER SEWER	---	PROPERTY LINE	---	VALVE	---
○	MANHOLE	+	SURVEY BAR	+	LAND DRAINAGE SEWER	---
□	CATCH BASIN	+	CURB STOP	+	WASTE WATER SEWER	---
△	CURB INLET	+	C.B. LEAD	---	JUNCTIONS	---
---	TRAFFIC SIGNAL	---	SIDEWALK	---	CULVERT	---
---	STEAM HT.	---	SIDEWALK RAMP	---	ASPH./CONC. PAD	---
---	GAS	---	ELEVATIONS	32.55	GARAGE PAD	---
---	EXISTING	---	LEGEND - PLAN	---	LEGEND - PROFILE	---
---	LEGEND - PLAN	---	PROPOSED	---	PROPOSED	---

LOCATION APPROVED			
SUPV. U/G STRUCTURES	DATE		
COMMITTEE			
NOTE: LOCATION OF UNDERGROUND STRUCTURES AS SHOWN ARE BASED ON THE BEST INFORMATION AVAILABLE BUT NO GUARANTEE IS GIVEN THAT ALL EXISTING UTILITIES ARE SHOWN OR THAT THE GIVEN LOCATIONS ARE EXACT. CONFIRMATION OF EXISTENCE AND EXACT LOCATION OF ALL SERVICES MUST BE OBTAINED FROM THE INDIVIDUAL UTILITIES BEFORE PROCEEDING WITH CONSTRUCTION.			
NO.	REVISIONS	DATE	BY

GENIVAR 10 PRAIRIE WAY WINNIPEG, MANITOBA R2J 3J8 PH: (204)-477-8650 FAX: (204)-474-2864	
DESIGNED BY: MBS	CHECKED BY: SM
DRAWN BY: MBS	APPROVED BY: IMcK
HOR. SCALE: 1:500	RELEASED FOR CONSTRUCTION
VERT. SCALE: 1:50	DATE: AUGUST 2010

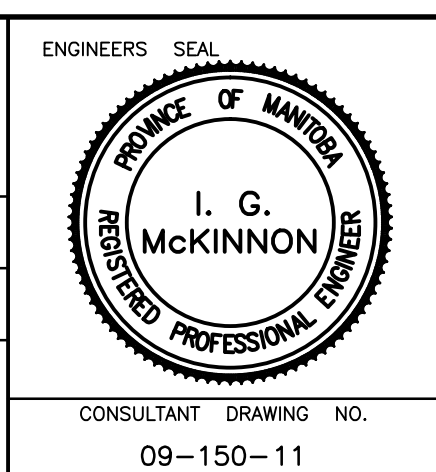

Winnipeg THE CITY OF WINNIPEG PUBLIC WORKS DEPARTMENT	
2010 ACTIVE TRANSPORTATION INFRASTRUCTURE STIMULUS PROGRAM DUGALD MULTI-USE PATH	
FROM MATCHLINE AT STATION 2+50 TO MATCHLINE AT STATION 6+00	
CITY DRAWING NO. N/A	SHEET 2 OF 8
TENDER NO. 544-2010	