

Drawing Title:

Drawing No:

TACHE BACKLESS BENCH COMPOSITE

SCD-142

MATERIALS:

- 100 mm x 100 mm COMPOSITE BOARDS
- CEDAR TONE FINISH
- METAL FINISH - PRIME WITH RUSTOLEUM NO. 769 FINISH WITH SAPOLIN BLACK WROUGHT FINISH

PRODUCT NO.# 52510169

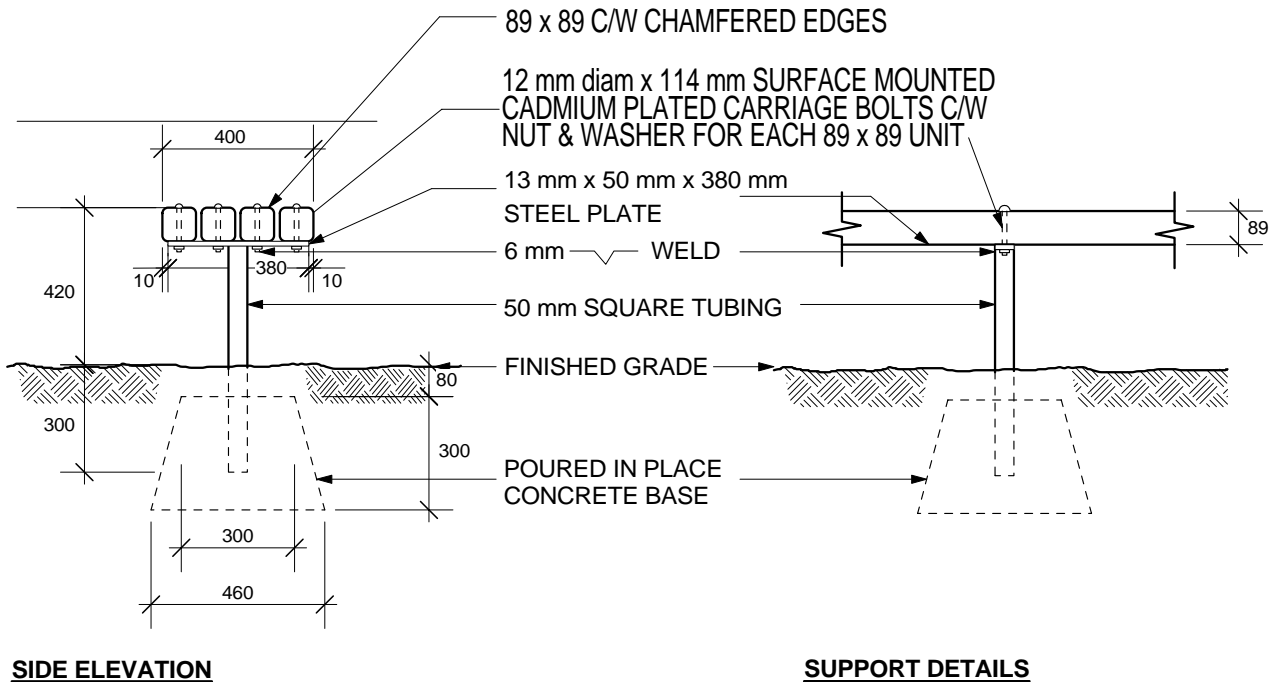
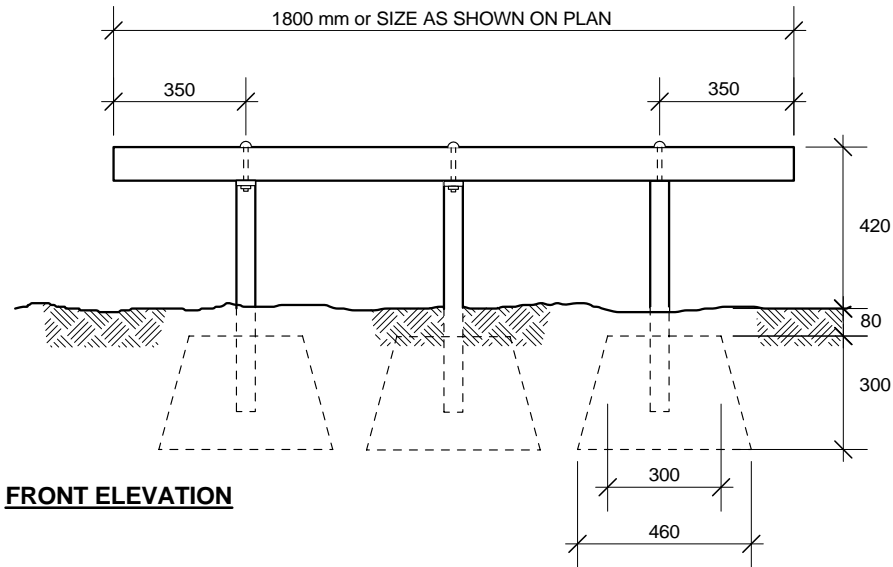

DIMENSIONS SHOWN ARE IN MILLIMETRES UNLESS OTHERWISE SPECIFIED

DATE: June, 2003
 SCALE: 1:20
 DRAWN BY: ST

The City of Winnipeg
 Planning, Property and Development Department
 Planning and Land Use Division
 Unit 15 - 30 Fort Street, Winnipeg, MB, R3C 4X5

