

FRONT COVER VIEW
SCALE 1:5

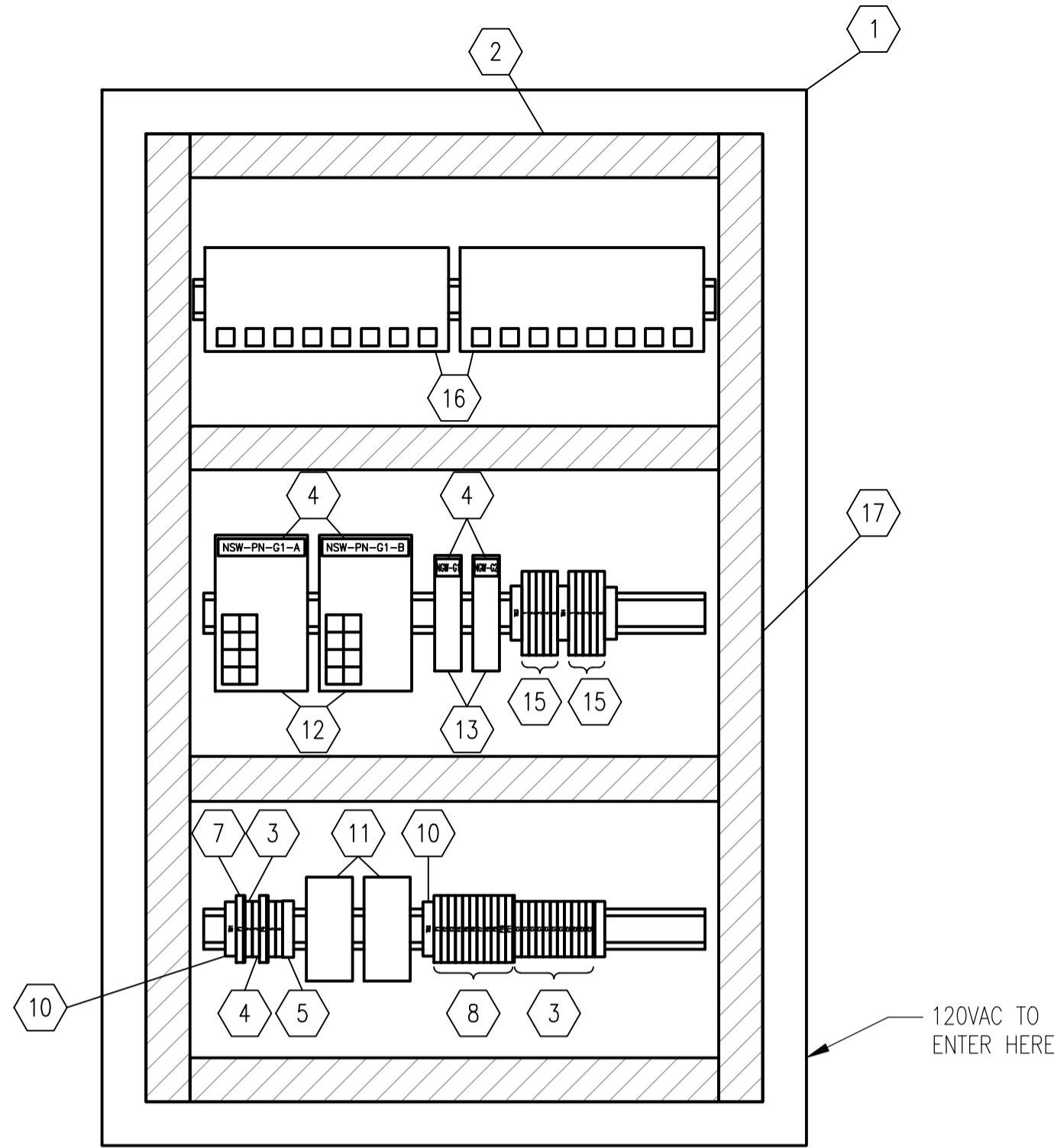

INSIDE VIEW
SCALE 1:5

BILL OF MATERIAL				
ITEM	QTY.	DESCRIPTION	MANUFACTURER	CATALOG NO.
1	1	NEMA 12 ENCL., HINGED DOOR - 914x610x203mm	HOFFMAN	A362408LP
2	1	BACK PLATE FOR ITEM 1	HOFFMAN	A36P24
3	9	UT-4 TERMINAL BLOCK, GREY	PHOENIX CONTACT	3044102
	AS REQ.	TERMINAL BLOCK END PLATE	PHOENIX CONTACT	3047167
	AS REQ.	TERMINAL MARKER	PHOENIX CONTACT	1051003
4	AS REQ.	PHENOLIC TYPE NAMEPLATE C/W 6.35mm (1/4") LETTERING	-	-
5	AS REQ.	TERMINAL END HOLDER	PHOENIX CONTACT	0800886
6	AS REQ.	MOUNTING RAIL	PHOENIX CONTACT	0801733
7	2	FUSE TERMINAL, 120 VAC, LED, C/W 2A FUSE	PHOENIX CONTACT	3046100
8	11	FUSE TERMINAL, 24 VDC LED, C/W 1A FUSE	PHOENIX CONTACT	3046090
9	-	NOT USED	-	-
10	4	TERMINAL GROUP LABEL HOLDER	PHOENIX CONTACT	1004348
11	2	24 VDC POWER SUPPLY, 120W	SOLA HD	SDN-5-24-100C
12	2	ETHERNET SWITCH, 7+3G PORTS	MOXA	EDS-P510A-3GT
13	2	MODBUS RTU/TCP GATEWAY	DIGI	DIGI ONE 1A
14	2	VT-4 GROUND TERMINAL BLOCK	PHOENIX CONTACT	3044128
15	10	DIKD 1.5 TERMINAL BLOCK	PHOENIX CONTACT	2715979
16	2	8 PORT PATCH PANEL	PHOENIX CONTACT	1654895
17	AS REQ'D	WIRING DUCT - 1.5" NARROW SLOT	PANDUIT	F1.5x2LG6 C1.5LG6
18	1	ARC FLASH STICKER OR LAMACOID	-	-

FUSE SCHEDULE			
TB	IDENTIFIER	TYPE	RATING
TB1	F1	5x20	2A, FAST ACTING
	F4	5x20	2A, FAST ACTING
TB2	F1	5x20	1A, FAST ACTING
	F2	5x20	1A, FAST ACTING
	F3	5x20	1A, FAST ACTING
	F4	5x20	1A, FAST ACTING
	F5	5x20	1A, FAST ACTING
	F6	5x20	1A, FAST ACTING
	F7	5x20	1A, FAST ACTING
	F8	5x20	1A, FAST ACTING
	F9	5x20	1A, FAST ACTING
	F10	5x20	1A, FAST ACTING
	F11	5x20	1A, FAST ACTING

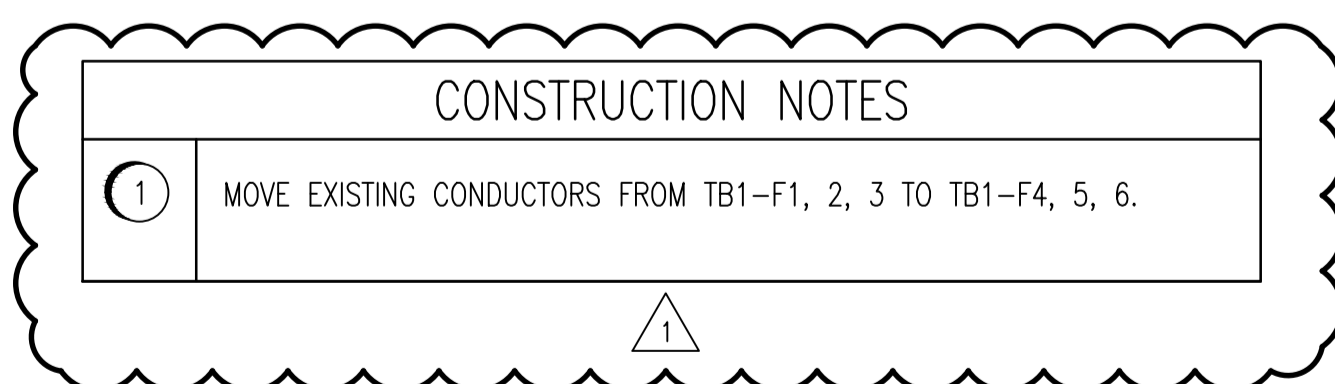

NOTES:

- LABEL ALL TERMINAL BLOCKS AS SHOWN ON THE DRAWINGS, COMPLETE WITH GROUP LABELING.
- SUPPLY AND INSTALL ALL REQUIRED FUSES. IN ADDITION, PROVIDE TWO SPARES OF EACH FUSE SIZE.
- PANEL IS TO BE CONSTRUCTED BY A PANEL SHOP AND BE CSA CERTIFIED.
- WHERE MANUFACTURER AND MODEL ARE SPECIFIED, SUBSTITUTIONS MUST BE APPROVED.
- ALL POWER WIRING TO BE TEW/MTW 600V, 105° INSULATION, STRANDED COPPER, 12 AWG.
- ALL RS485 WIRING TO BE TWISTED PAIR, 22 AWG MINIMUM.
- TEST ALL WIRING AND COMPONENTS FOR FUNCTIONAL OPERATION, CORRECT CONNECTION, CONTINUITY AND INSULATION INTEGRITY.
- ALL MAJOR COMPONENTS INSIDE THE PANEL ARE TO BE LABELED WITH LAMACOIDS IN ACCORDANCE WITH MAJOR DESCRIPTIONS ON THE DRAWINGS.
- PROVIDE WIRE BARREL FERULES FOR THE WIRING.
- MARK ALL WIRES AS SHOWN ON THE DRAWINGS.

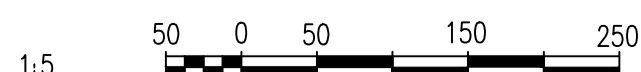

WIRING DIAGRAM:

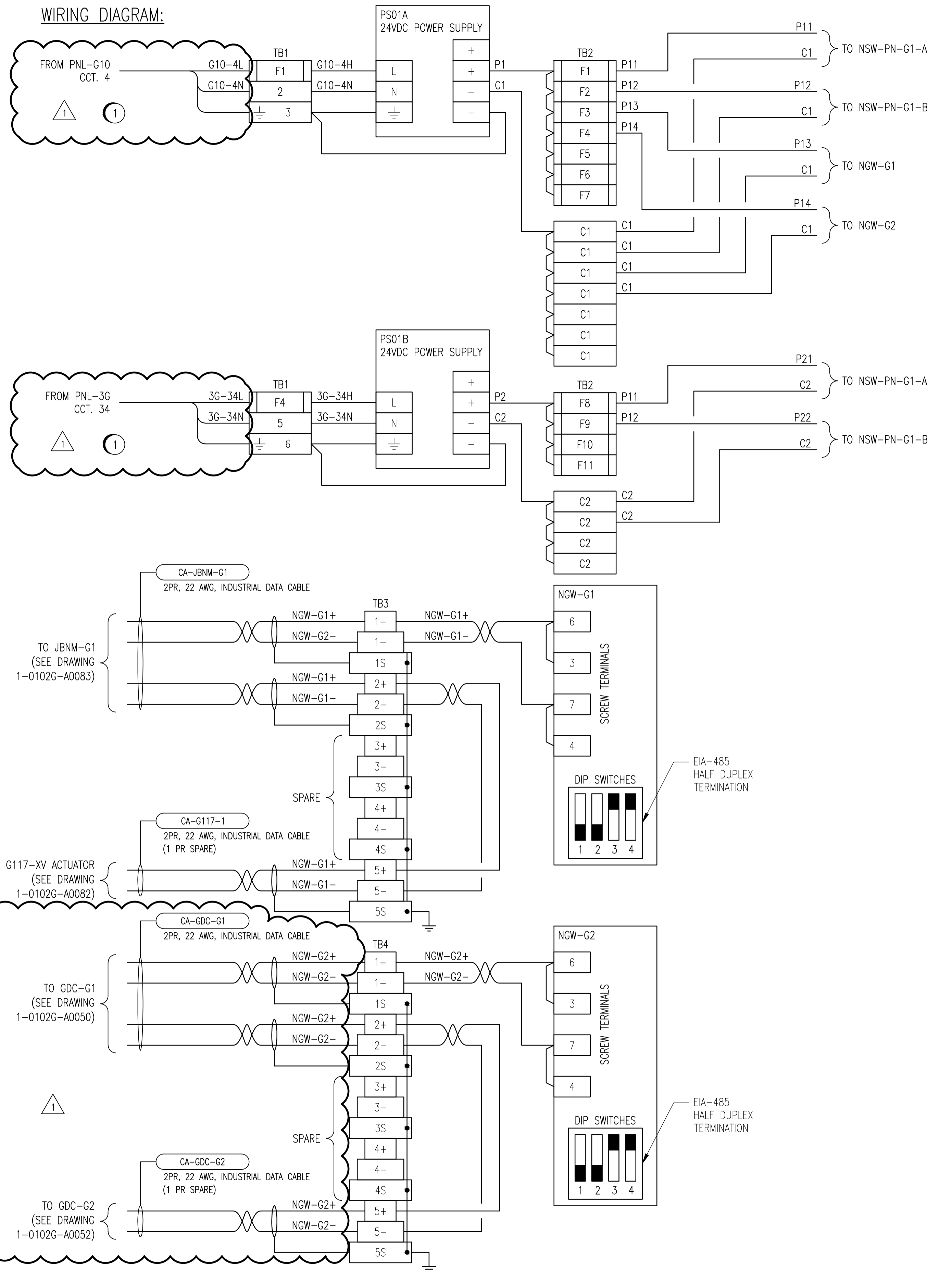

1-0102G-A0087	GRIT BUILDING ETHERNET BLOCK DIAGRAM
1-0102G-A0048	MODBUS NETWORK BLOCK DIAGRAM
DRAWING NUMBER	REFERENCE DRAWINGS

NO.	REVISIONS	DATE	DESIGN	CHECK
01	GAS DETECTION MODIFICATIONS	2011/03/11	TMC	CJR
00	ISSUED FOR TENDER	2010/10/01	TMC	CJR

SNC-LAVALIN INC.
148 Nature Park Way
Winnipeg, MB, Canada R3P 0X7
204-786-8080

DESIGNED BY: T. CHURCH
DRAWN BY: S. COATES
SCALE: AS SHOWN
DATE: 2010/03/16
CONSULTANT NO.: 112577-0106-480D-0306

CHECKED BY: C. REIMER
APPROVED BY: C. REIMER
RELEASED FOR CONSTRUCTION BY: J. VEILLEUX
DATE: 2010/10/01

ENGINEER'S SEAL

ORIGINAL DRAWING SEALED BY:
T. M. CHURCH
SNC-LAVALIN
MEMBER #32682
2011/03/25
REV. 01
CHANGES ONLY

THE CITY OF WINNIPEG
WATER AND WASTE DEPARTMENT

SOUTH END WATER POLLUTION CONTROL CENTRE
HEADWORKS UPGRADES
PANEL LAYOUT
NP-G1

CITY DRAWING NUMBER: 1-0102G-A0072
SHEET: 001
REV: 01
SIZE: A1