

B SIZE - 279mm x 432mm

LAST SAVE: 2011/03/29 - 11:26am  
 PATH: M:\112577\0106\4ENG\47ELE\DD - General DWG\1-0102G-A0073-001-00.dwg

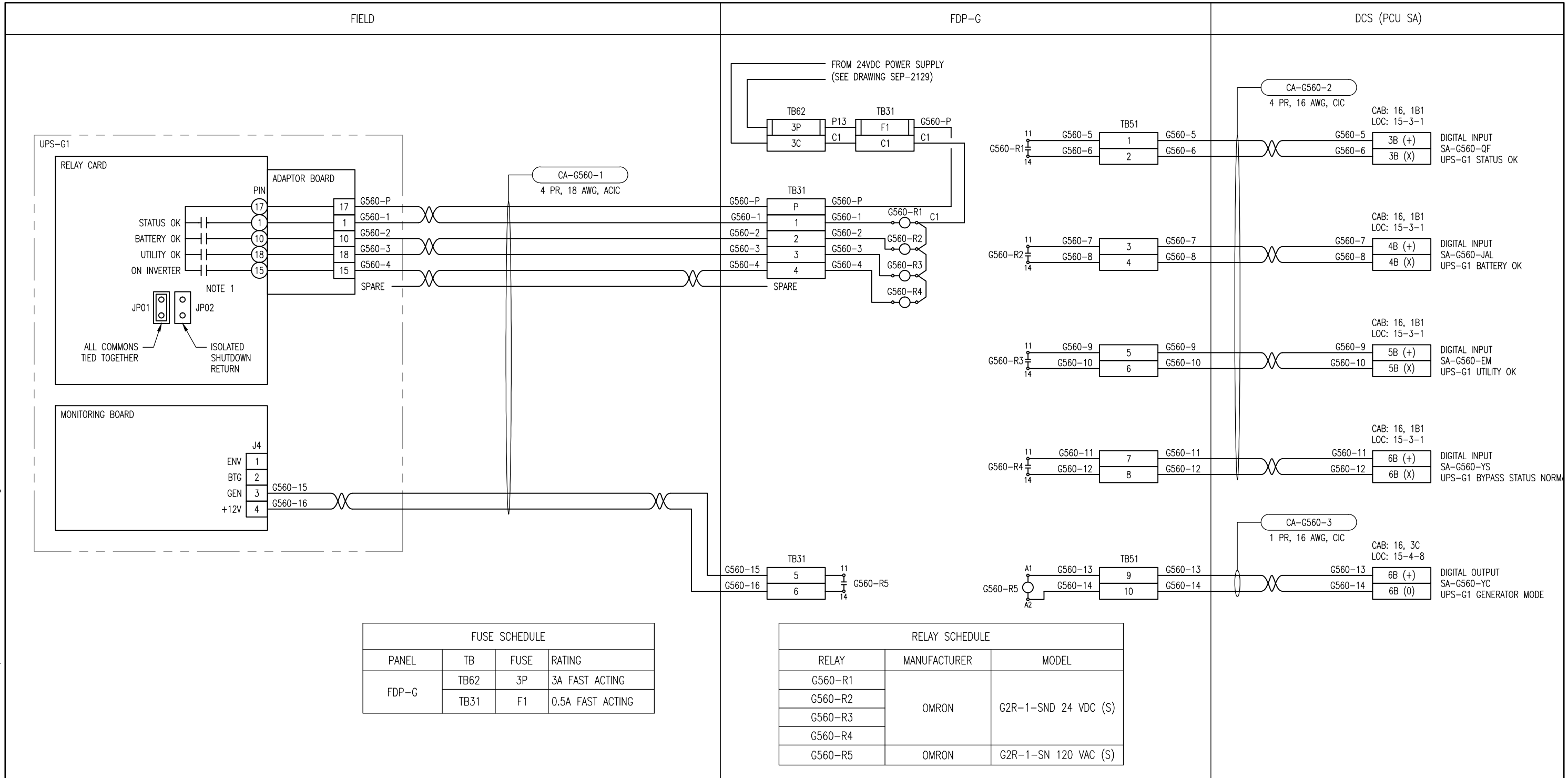

FUSE SCHEDULE			
PANEL	TB	FUSE	RATING
FDP-G	TB62	3P	3A FAST ACTING
	TB31	F1	0.5A FAST ACTING

RELAY SCHEDULE		
RELAY	MANUFACTURER	MODEL
G560-R1	OMRON	G2R-1-SND 24 VDC (S)
G560-R2		
G560-R3		
G560-R4		
G560-R5	OMRON	G2R-1-SN 120 VAC (S)

**NOTES:**  
 1. CONTACTS SHOWN IN DE-ENERGIZED STATE.



NO.	REVISIONS	DATE	DESIGN	CHECK
00	ISSUED FOR TENDER, BID OPP. 209-2011	2011/03/11	TMC	CJR

DESIGNED BY: T. CHURCH	CHECKED BY: C. REIMER
DRAWN BY: S. COATES	APPROVED BY: C. REIMER
SCALE: N.T.S.	DATE: 2009/10/19
RELEASED FOR CONSTRUCTION	
BY: N. HARRINGTON	DATE: 2011/03/11
CONSULTANT NO.: 112577-0106-47DD-1200	

ENGINEER'S SEAL  
 ORIGINAL DRAWING SEALED BY:  
 T. M. CHURCH  
 SNC-LAVALIN  
 2011/03/25  
 REV. 00

**THE CITY OF WINNIPEG**  
 WATER AND WASTE DEPARTMENT

**SOUTH END WATER POLLUTION CONTROL CENTRE**  
 ESSENTIAL SYSTEM UPGRADES  
 INSTRUMENT LOOP DIAGRAM  
 UPS-G1 ALARMS

CITY DRAWING NUMBER	SHEET	REV.	SIZE
1-0102G-A0073	001	00	B