

ALLEY PAVEMENT PROFILE

SCALE: 1:250 HOR
1:10 VER

MATCH LINE
STA. 2+25

MATCH LINE
STA. 3+50

ALLEY PAVEMENT PLAN

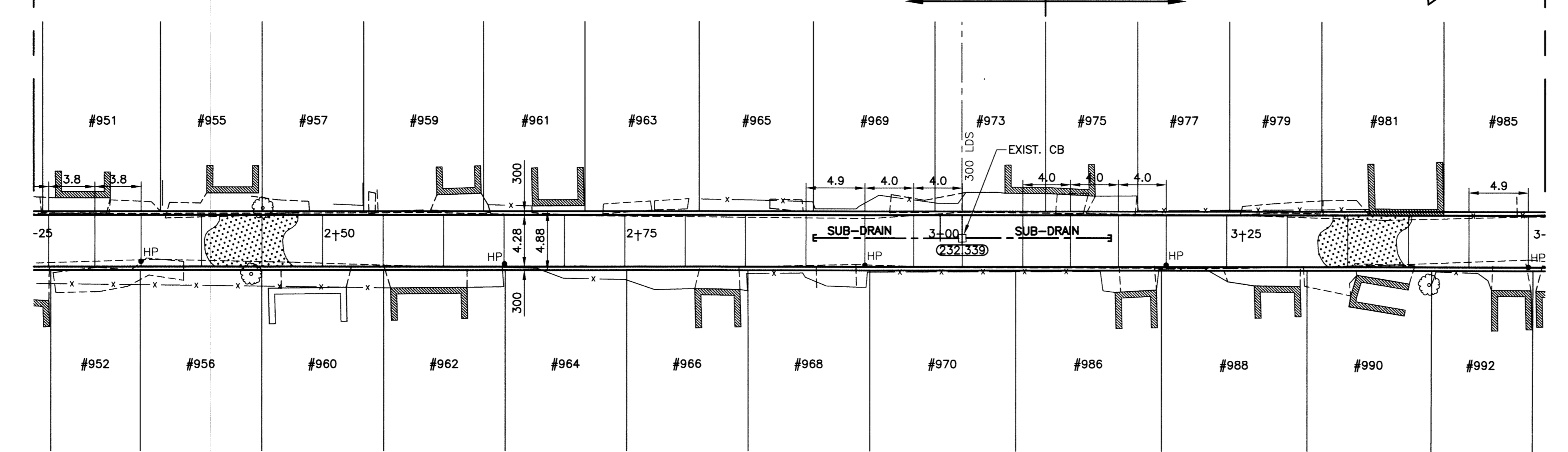

ALLEY PAVEMENT PLAN
SCALE: 1:250 HOR

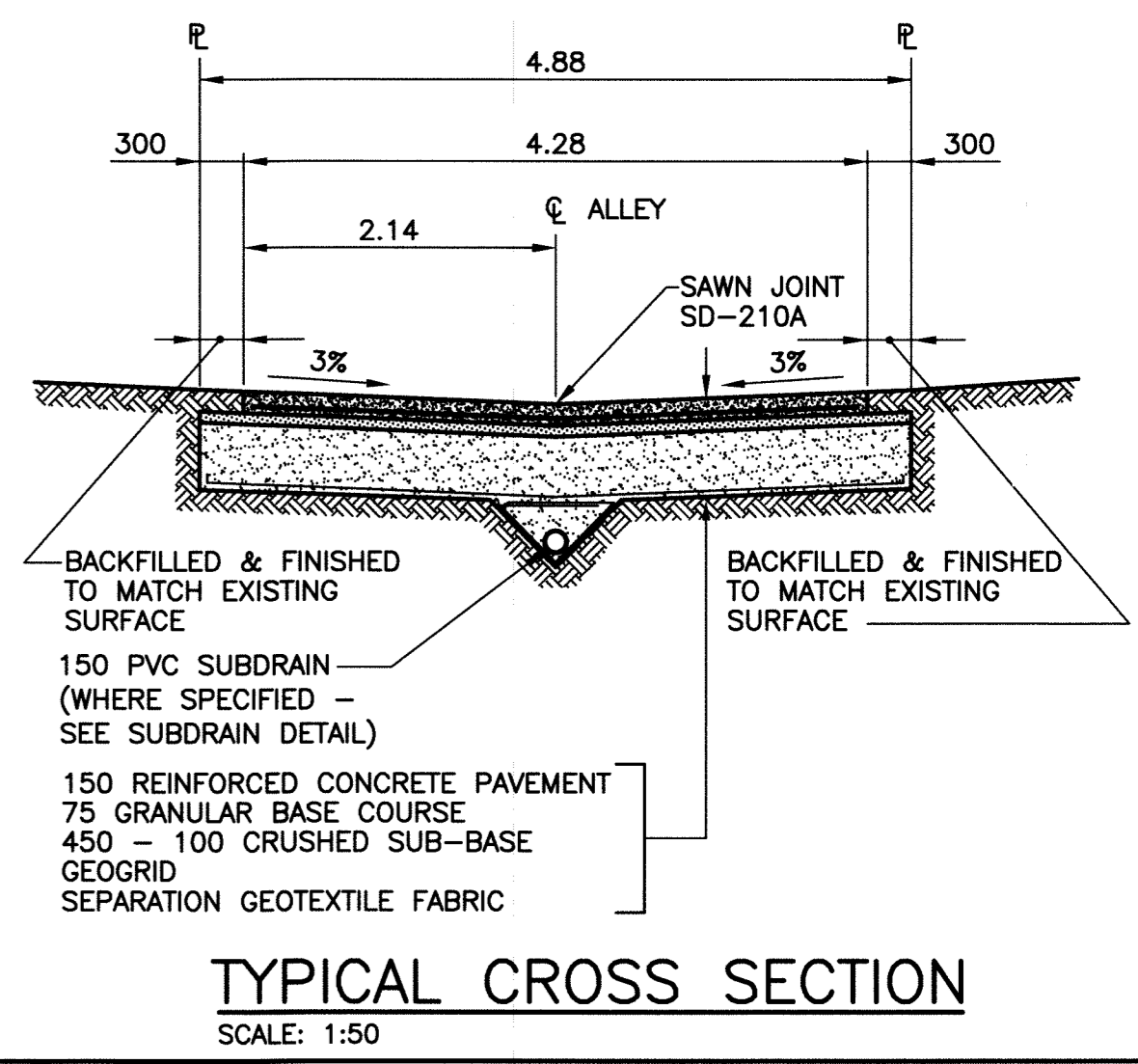

TYPICAL CROSS SECTION

SCALE: 1:50

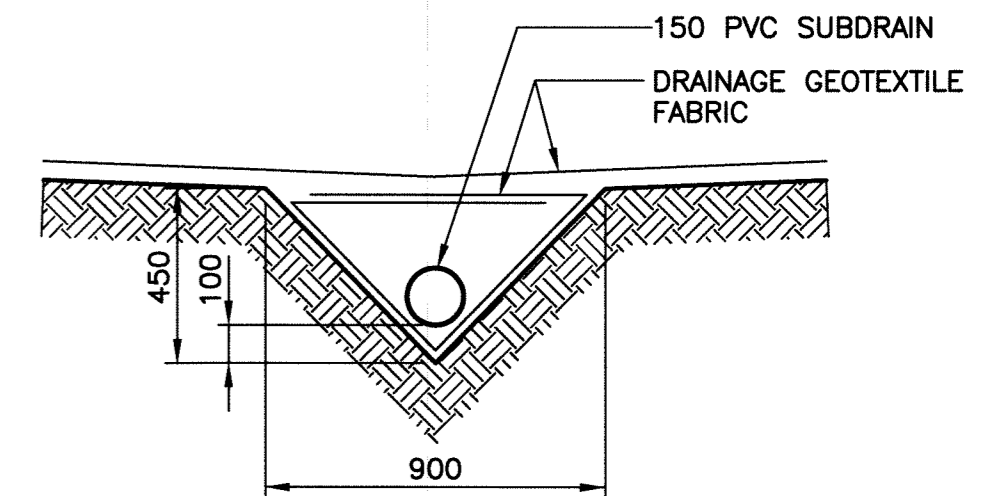

SUBDRAIN DETAIL

SCALE: 1:20

- NOTE:**
1. STATION CHAINAGE IS BASED ON CENTERLINE OF ALLEY RIGHT OF WAY.
 2. ADJUST MH AND CB RIMS TO NEW GRADES.
 3. PLUG SUBDRAINS AT TERMINAL ENDS.
 4. REGRADE EXISTING PRIVATE SIDEWALKS AS REQUIRED.
 5. INSTALLATION OF LIP CURBS AND THEIR EXTENTS TO BE DETERMINED BY THE CONTRACT ADMINISTRATOR.
 6. LIGHT STANDARDS, HYDRO POLES AND ANCHORS MAY REQUIRE TEMPORARY SUPPORT/REMOVAL OR REPLACEMENT AT THE CONTRACTOR'S EXPENSE.
 7. ISOLATE ALL POLES, BASES AND PILES WITHIN ALLEY RIGHT OF WAY (SD-228C).
 8. AVOID DAMAGE TO EXISTING TREES WITHIN THE LIMITS OF CONSTRUCTION.

PROPERTY LIMITS DELINEATION

DELINEATION OF PROPERTY LIMITS AS SHOWN ON THIS DWG DOES NOT REPRESENT A "LEGAL SURVEY". KGS GROUP MAKES NO REPRESENTATION OR WARRANTY AS TO THE ACCURACY OF PROPERTY LIMITS DELINEATED ON THIS DWG, NOR ON THE DIMENSIONAL ACCURACY OF DWG FEATURES RELATIVE TO THOSE PROPERTY LIMITS.

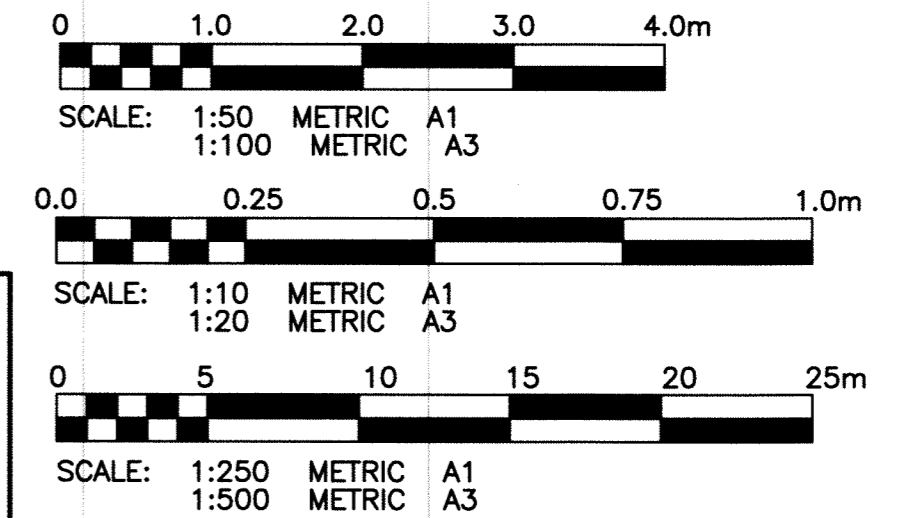

METRIC
WHOLE NUMBERS INDICATE MILLIMETRES
DECIMALIZED NUMBERS INDICATE METRES

WARNING

IF POWER EQUIPMENT OR EXPLOSIVES ARE TO BE USED FOR EXCAVATION ON THIS PROJECT THE CONTRACTOR MUST:

- 1) NOTIFY THE GAS COMPANY OF THE PROPOSED LOCATION OF EXCAVATION.
- 2) TAKE PRECAUTION TO AVOID DAMAGE TO GAS COMPANY INSTALLATIONS.

SEE PROVINCIAL REGULATION 210/72 FOR DETAILS.

P:\Projects\2011\11-0107-10\DocControl\Belissand\DWG\11-0107-10-14-Rev 0.dwg - Tab: 14 Plotted By: Dberoch 06/28/2011 [Tue 8:38am] PLOT 1:1 A-1

300 L.DS.	LAND DRAINAGE SEWER	300 L.DS.	TEST HOLE			
250 WWS	WASTE WATER SEWER	250 WWS	GUY WIRE			
	GAS		LIGHT STANDARD			
	HYDRO		BACK OF CURB			
	M.T.S.		CONCRETE			
150 WM	WATERMAIN	150 WM	ASPHALT			
	HYDRANT		SIDEWALK			
	VALVE		PROPERTY LINE			
	MANHOLE		SURVEY BAR			
	CATCH BASIN		GEODETIC BENCHMARK			
	CURB INLET		ELEVATION			
	POLES					
EXISTING	LEGEND-PLAN	PROPOSED	EXISTING	LEGEND-PLAN	PROPOSED	EXISTING

LOCATION APPROVED UNDERGROUND STRUCTURES

SUPV. U/G STRUCTURES COMMITTEE DATE

NOTE:
LOCATION OF UNDERGROUND STRUCTURES AS SHOWN ARE BASED ON THE BEST INFORMATION AVAILABLE. BUT NO GUARANTEE IS GIVEN THAT ALL EXISTING UTILITIES ARE SHOWN OR THAT THE GIVEN LOCATIONS ARE EXACT. CONFIRMATION OF EXISTENCE AND EXACT LOCATION OF ALL SERVICES MUST BE OBTAINED FROM THE INDIVIDUAL UTILITIES BEFORE PROCEEDING WITH CONSTRUCTION.

B.M.	36.061	N.W. Cor. Sargent Ave. 7 Garfield St. N. 10ft. in S. Conc. foundation of Sargent Ave. Memorial Church.
ELEV.	233.373	0.5m W. & 1.7m below brick of S.E. Cor. of Bldg.
NO.	REVISIONS	DATE
0	ISSUED FOR TENDER	11/06/27
		DATE

APEGM
Certificate of Authorization
KGS Group
No. 245

KGS GROUP
CONSULTING ENGINEERS

DESIGNED BY	MSM	CHECKED BY	RBO
DRAWN BY	DMW	APPROVED BY	P/H
HOR. SCALE:	1:250	RELEASED FOR CONSTRUCTION:	
VERTICAL:	1:50	DATE	11/06/06

ENGINEER'S SEAL
PROVINCE OF MANITOBA
M.S.E.
MANZANO
Member
22204

THE CITY OF WINNIPEG
PUBLIC WORKS DEPARTMENT
TRANSPORTATION ENGINEERING DIVISION

PROJECT TITLE
2011 ALLEY RENEWAL PROGRAM
GARFIELD ST./SHERBURN ST.
SARGENT AVE. TO WELLINGTON AVE.
STA. 2+25 TO STA. 3+50

SHEET OF
14 OF **18**

COMPUTER FILE NAME
GARFIELD_SHERBURN

CITY DRAWING NUMBER
P-XX14

CONSULTANT DRAWING NO.
11-0107-10