

**A** DIGESTER TANK NO. 11 SECTION  
1:50

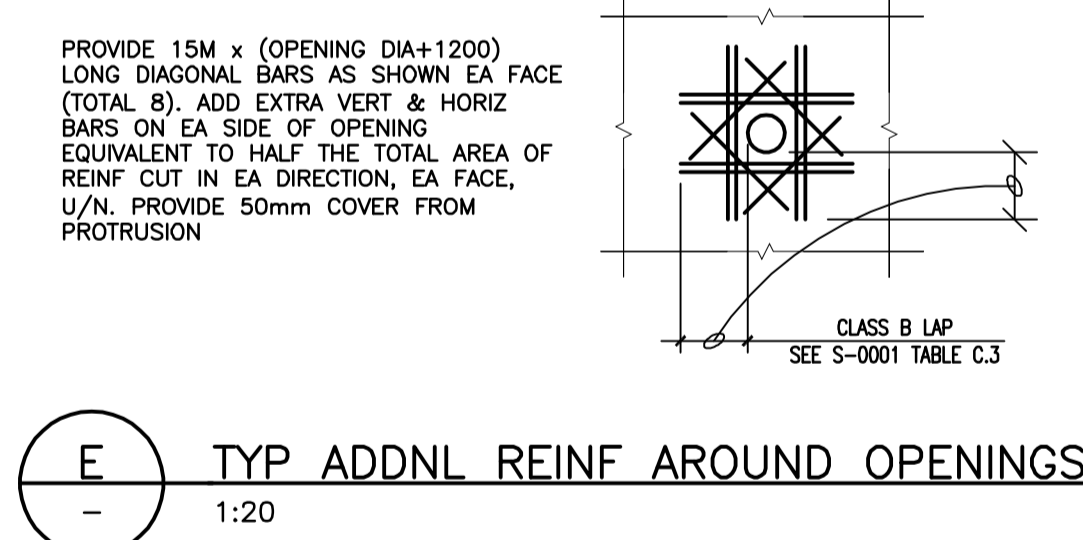

**E** TYP ADDNL REINF AROUND OPENINGS  
1:20

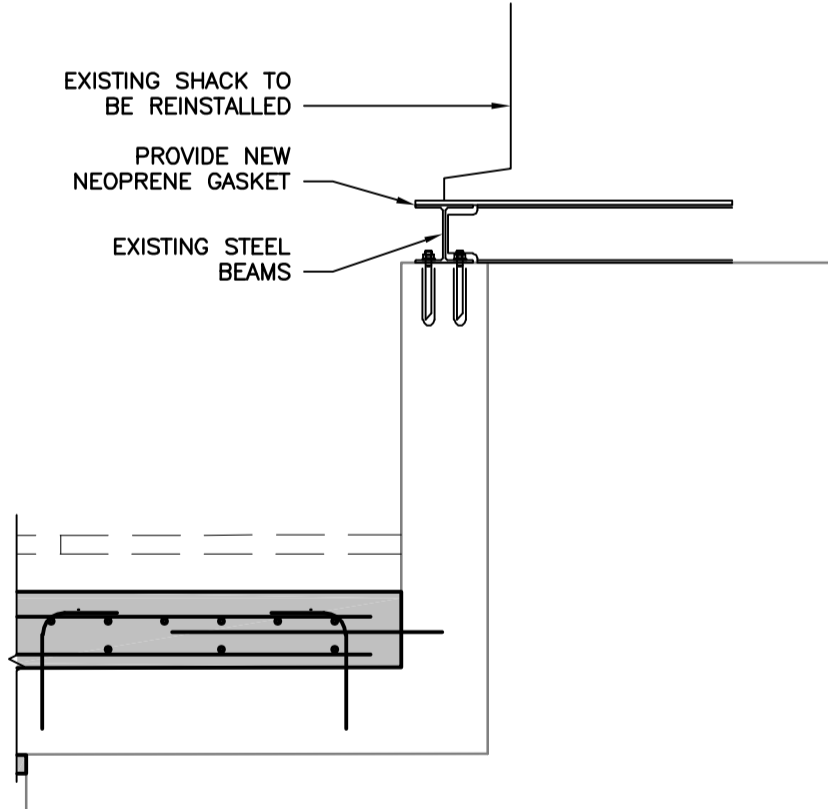

**F** SECTION  
1:20

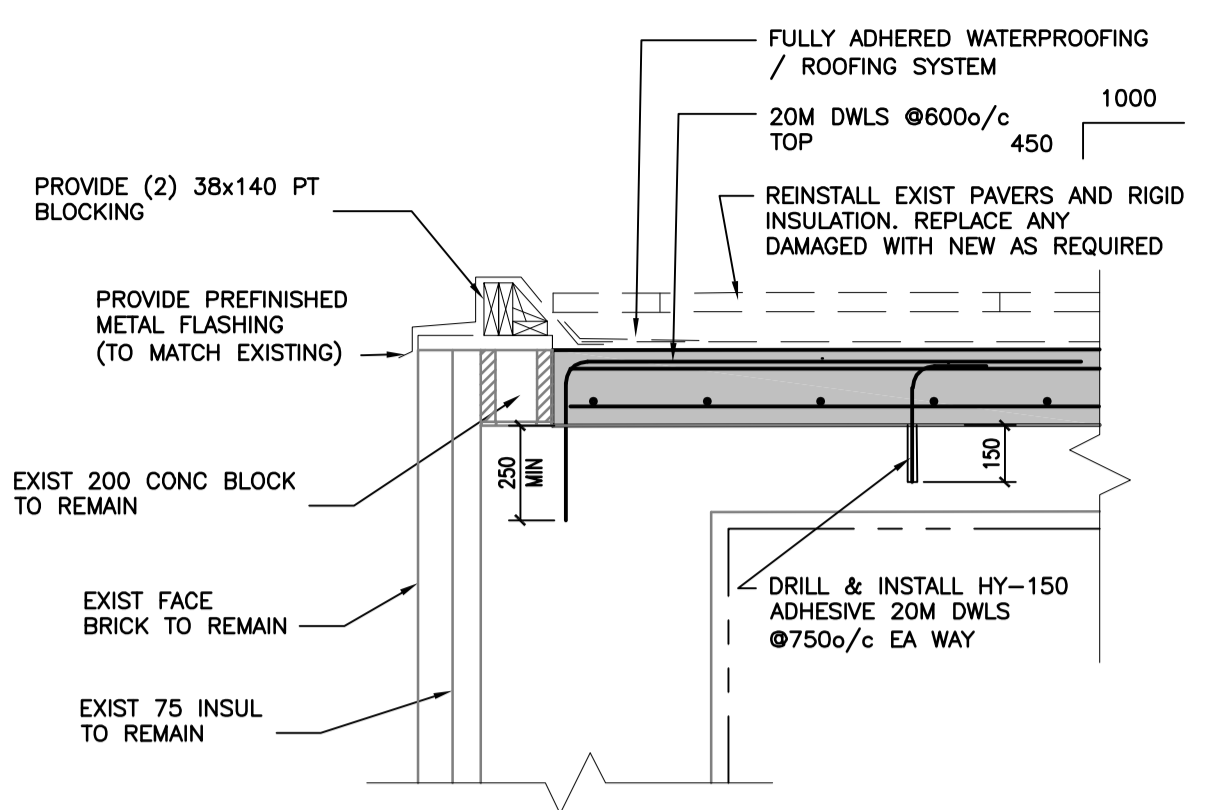

**B** SECTION  
1:20

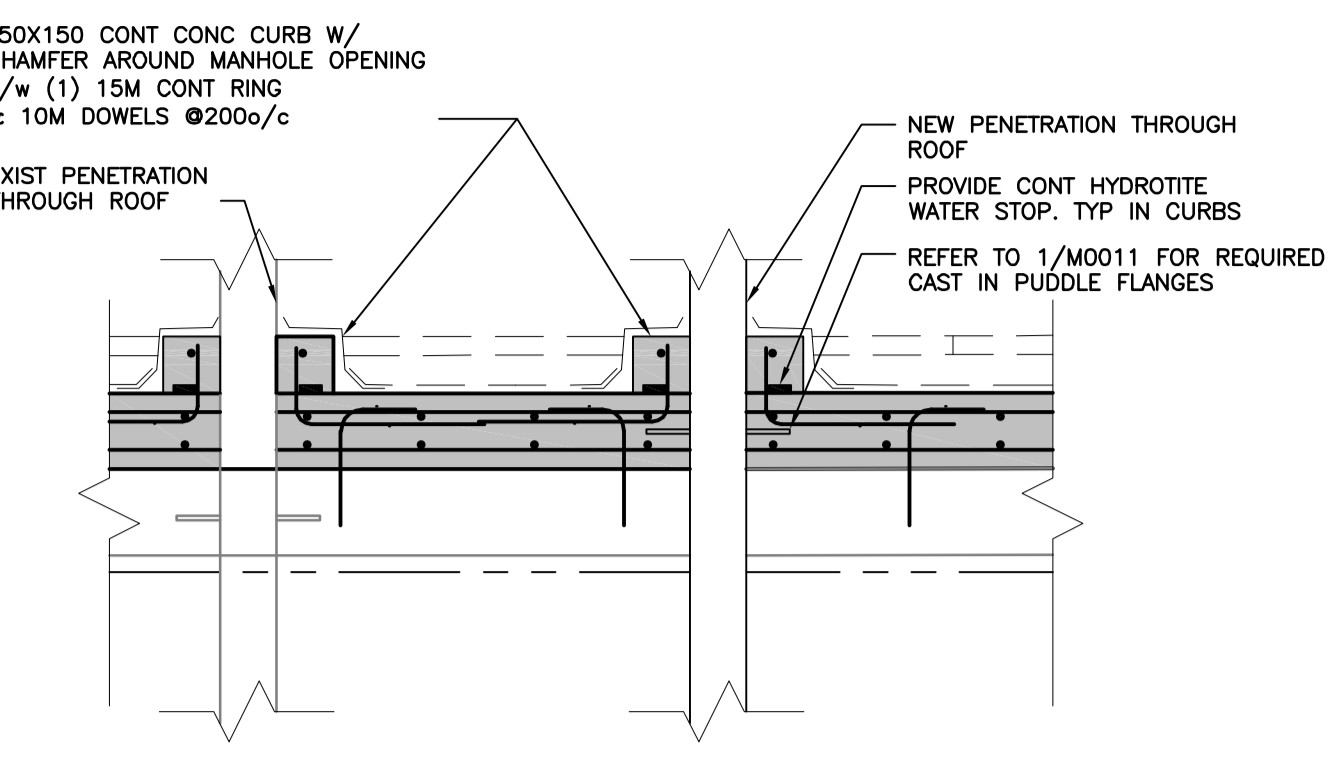

**C** TYPICAL SAMPLING PORT PENETRATION THROUGH ROOF DETAIL  
1:20

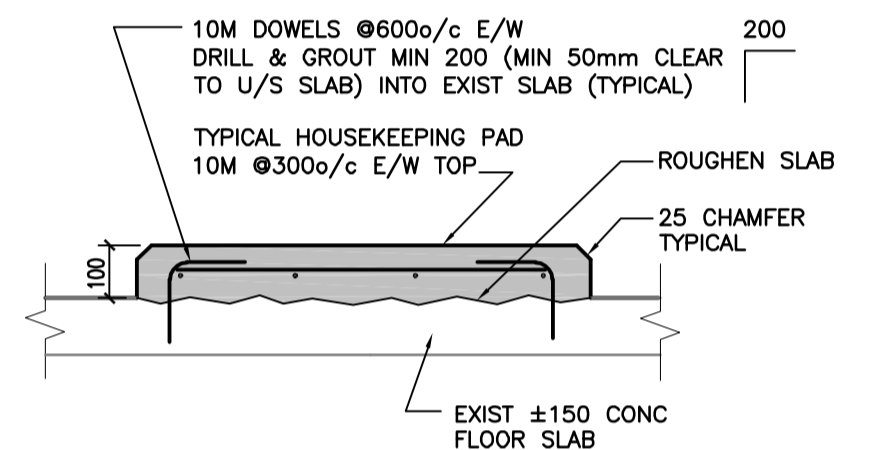

**D** TYP CONC HOUSEKEEPING PAD & CONC CURB DETAILS  
1:20

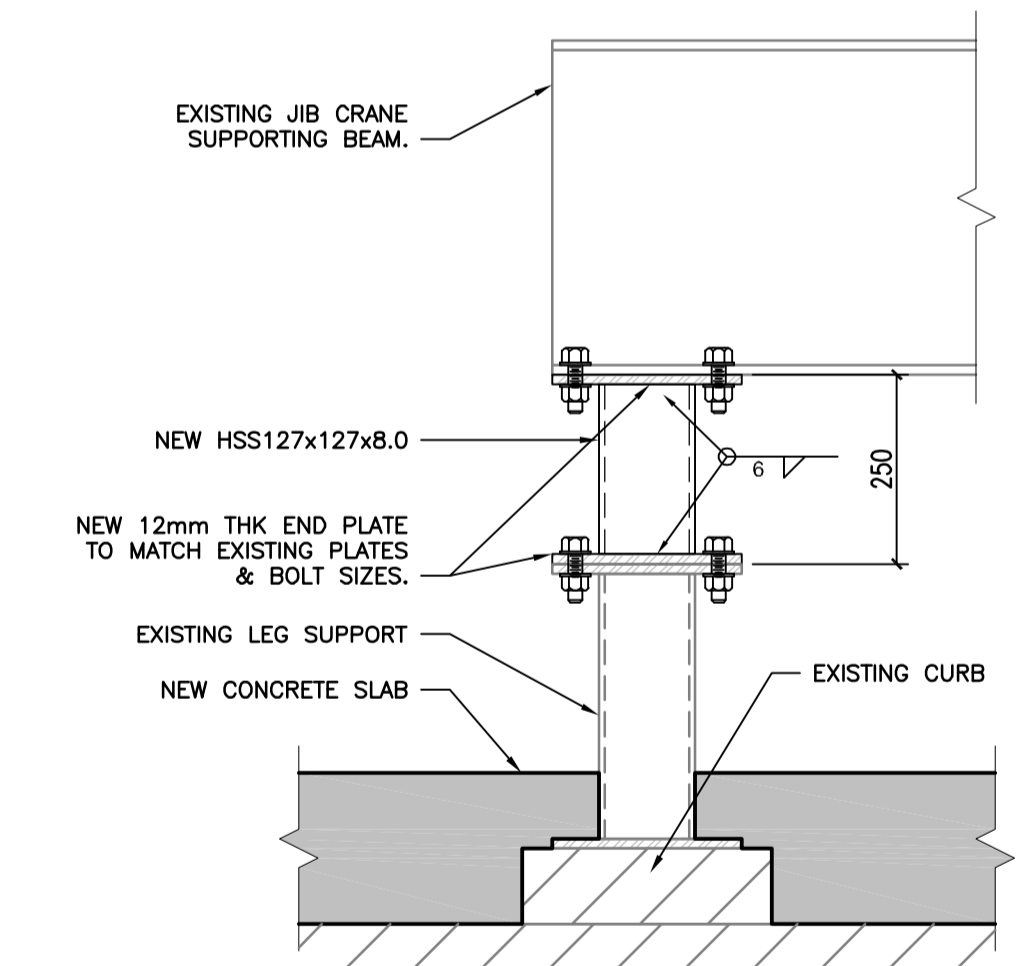
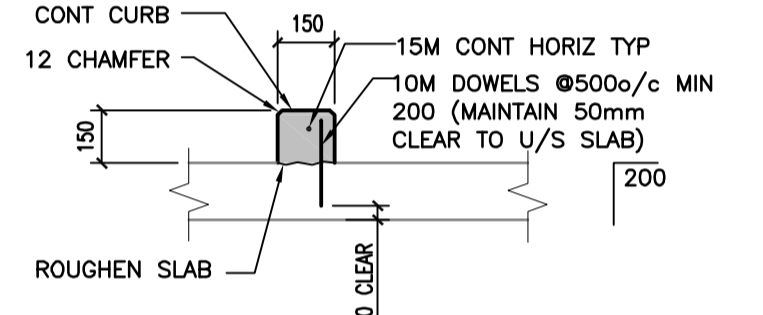

**G** JIB CRANE CONN SECTION  
1:10

V:\1117\winnipeg\111712020\_MSR\CC\_Digester\Drawings\02\_design\Sheet\_03\_struct\1-01010-S0004-001.dwg  
2012 October 10, 11:51 AM



LOCATION APPROVED UNDERGROUND STRUCTURES			
SUPV. U/G STRUCTURES COMMITTEE	DATE		
NOTE: LOCATION OF UNDERGROUND STRUCTURES AS SHOWN ARE BASED ON THE BEST INFORMATION AVAILABLE BUT NO GUARANTEE IS GIVEN THAT ALL EXISTING UTILITIES ARE SHOWN OR THAT THE GIVEN LOCATIONS ARE EXACT. CONFIRMATION OF EXISTENCE AND EXACT LOCATION OF ALL SERVICES MUST BE OBTAINED FROM THE INDIVIDUAL UTILITIES BEFORE PROCEEDING WITH CONSTRUCTION.			
NO.	REVISIONS	DATE	BY
3	ISSUED FOR TENDER	12.11.01	S.K.B
2	ISSUED FOR 95% REVIEW	12.09.12	S.K.B
1	ISSUED FOR 60% REVIEW	12.07.27	S.K.B

B.M. ELEV.			
DESIGNED BY	B.F.	CHECKED BY	BF
DRAWN BY	I.R.	APPROVED BY	S.K.B.
HOR. SCALE:	AS SHOWN	RELEASED FOR CONSTRUCTION:	
VERTICAL:		DATE	2011.12.15

**Stantec Consulting Ltd.**  
905 Waverley Street, Winnipeg, Manitoba  
Tel 204-489-5900 Fax 204-453-9012

ENGINEER'S SEAL  
**ORIGINAL SEALED BY B.E. FRASER P. ENG. 12.11.01**

**THE CITY OF WINNIPEG**  
WATER AND WASTE DEPARTMENT

**Winnipeg**

**NORTH END WATER POLLUTION CONTROL CENTRE**  
REHABILITATION OF DIGESTER No. II AND SLUDGE TANK No. 5 AND 7

**DIGESTER No. II - PLANS & SECTIONS**

BID OPPORTUNITY NO. 573-2012  
CITY DRAWING NUMBER I-0101D-S0004-001  
SHEET 6 OF 29