

	PRIOR (HP)	NEW (HP)
EF-1	0.75	0.75
MUA-1	1	5
TOTAL LOAD	1.75	5.75
NET NEW LOAD		4

**NOTES:**

1. ALL CONTROL WIRING BY MECHANICAL CONTRACTOR.
2. MATCH INTERRUPTING RATING OF EXISTING BREAKERS.
3. SHADED DENOTES EXISTING. NOT ALL LOADS SHOWN.

**LEGEND:**

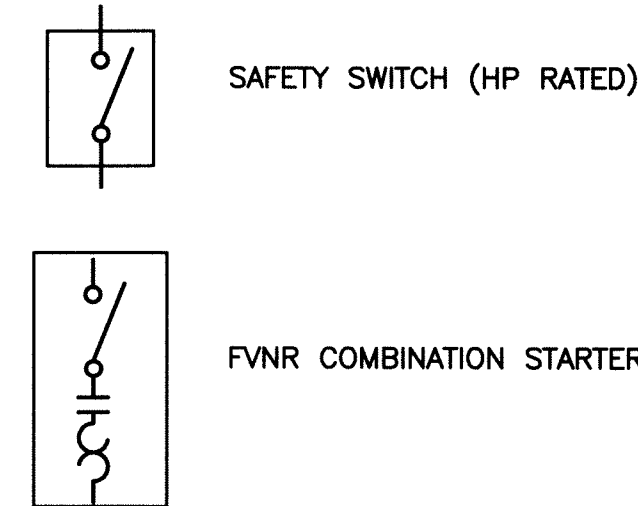

**NOTES:**

THESE DRAWINGS SHALL NOT BE SCALED.

THE CONTRACTOR SHALL VISIT THE SITE AND SATISFY ONESELF ALL DIMENSIONS, DATUM, AND DETAILED INFORMATION SHOWN ARE CORRECT.

THE CONTRACTOR IS TO REVIEW AND COORDINATE ALL ARCHITECTURAL, MECHANICAL, ELECTRICAL AND STRUCTURAL DRAWINGS FOR ADDITIONAL OPENINGS THROUGH FLOORS, WALLS, AND CEILINGS FOR DUCT, PIPE & ELECTRICAL RISERS AND ALL OPENINGS NOT SHOWN ON DRAWINGS.

ALL OPENINGS THROUGH FIRE ASSEMBLIES ARE TO BE FIRE STOPPED AND SEALED WITH UL/C APPROVED FIRE STOPPING TO MAINTAIN THE INTEGRITY OF THE FIRE SEPARATION AND PROVIDE A SMOKE-TIGHT BARRIER.

ALL PRODUCTS AND MATERIALS TO BE USED AND INSTALLED SHALL CONFORM WITH MANUFACTURER'S SPECIFICATIONS & APPLICABLE CODES.

THE CONTRACTOR SHALL BE RESPONSIBLE TO PATCH AND MAKE GOOD ALL EXISTING CONSTRUCTION AFFECTED BY THE REMOVAL OF ALL ITEMS FORMING THE PART OF THE RENOVATION WORK.

WHERE NEW FLOORING AND BASE IS TO BE INSTALLED IN EXISTING AREAS (REFER TO FLOOR PLAN AND ROOM SCHEDULE) THE EXISTING FLOORING SURFACE AND BASE MUST BE REMOVED UNLESS OTHERWISE NOTED. ALL FLOOR SURFACES SHALL BE PREPARED IN ACCORDANCE TO MANUFACTURER'S RECOMMENDATIONS FOR INSTALLATION OF NEW FLOOR.

WHERE PAINTING OF EXISTING WALLS IS INDICATED ON THE ROOM SCHEDULE, THESE WALLS MUST BE CLEANED OF ANY EXISTING WALL COVERING, PATCHED & PREPARED TO ACCEPT NEW MATERIAL, UNLESS OTHERWISE NOTED.

SHEET No:	SHEET TITLE
E01	NORTH SHOP - SINGLE LINE DIAGRAM
E02	NORTH SHOP - ELECTRICAL POWER PLAN
E03	NORTH SHOP - ELECTRICAL PROJECT SPECIFICATION

No.	REVISION/DESCRIPTION	BY	DATE
1	ISSUED FOR CONSTRUCTION	R.B.G.	2013 02/08
0	ISSUED FOR TENDER	R.B.G.	2012 07/17

SEAL



DRAWN	JPL	CHECKED	DESIGNED	DAK	APPROVED
DATE	2012.04.16	USER			APPROVAL

THE CITY OF WINNIPEG  
PLANNING, PROPERTY AND  
DEVELOPMENT DEPARTMENT  
MUNICIPAL ACCOMMODATIONS DIVISION  
3-65 GARRY STREET, R3C 4K4

PROJECT  
NORTH SHOP 2170 MAIN STREET  
HVAC UPGRADE

SHEET TITLE  
ELECTRICAL  
SINGLE LINE

SCALE	PROJECT No:	SHEET No:
AS SHOWN	12-0107-003	E01

