

ELEVATION
NTS

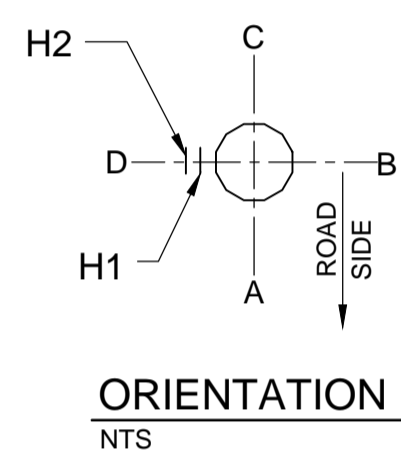

ORIENTATION
NTS

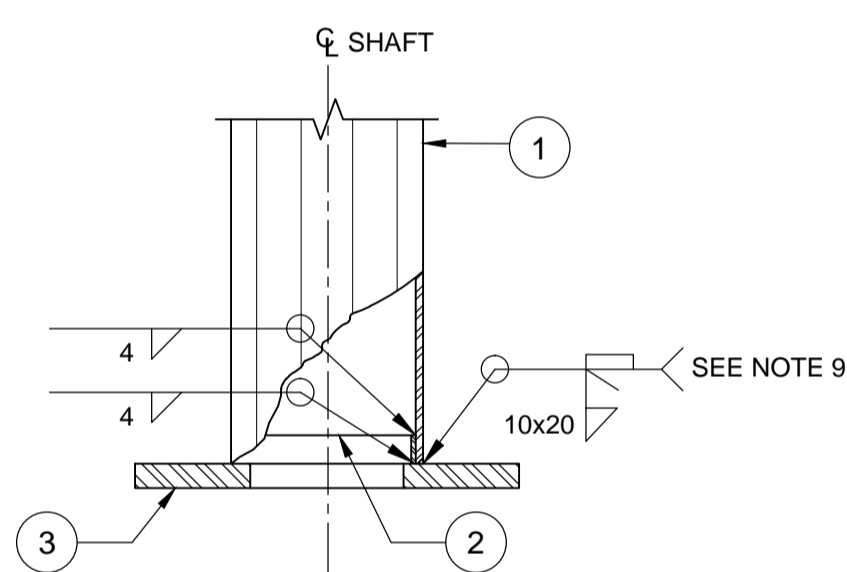

DETAIL
NTS

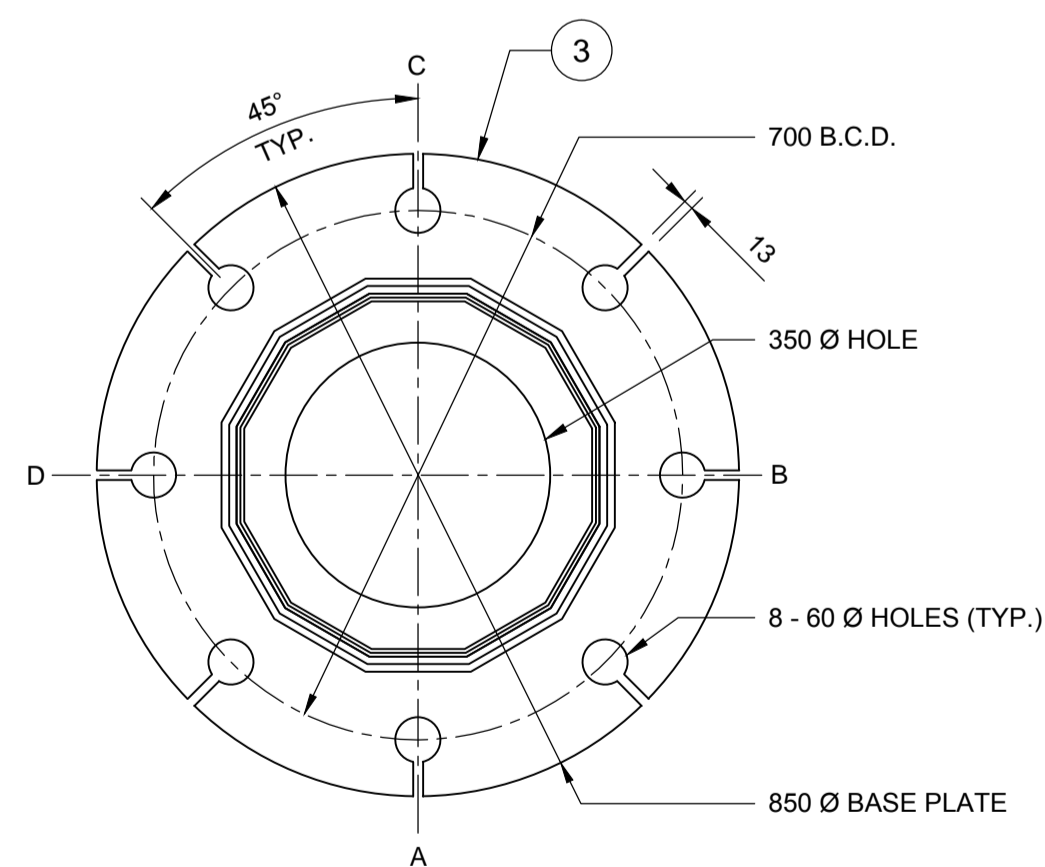

BASE PLATE DETAIL
NTS

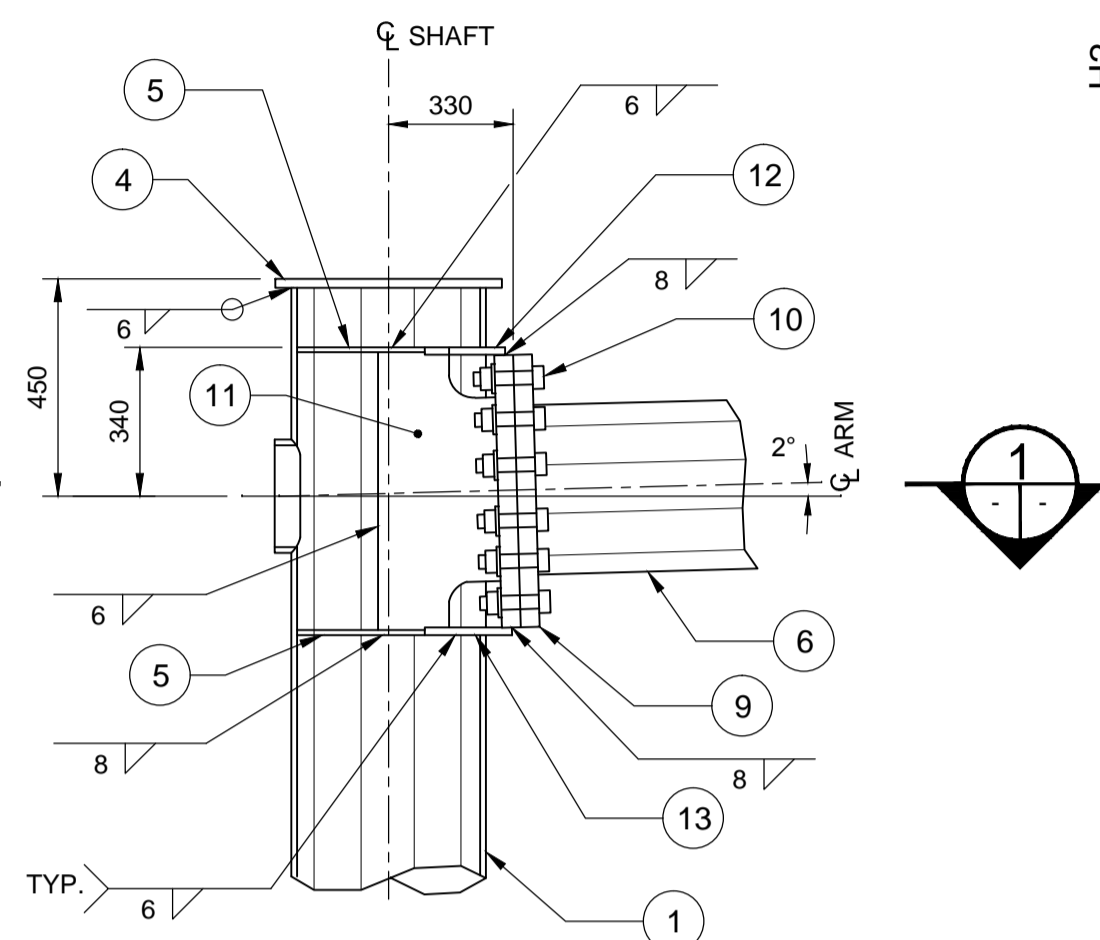

DETAIL
NTS

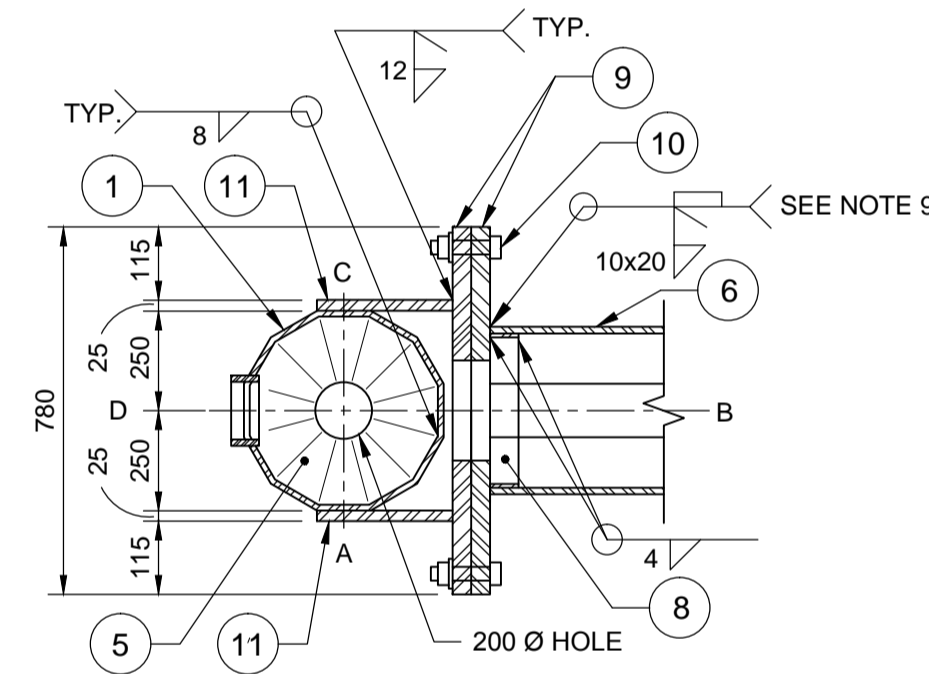

SECTION
NTS

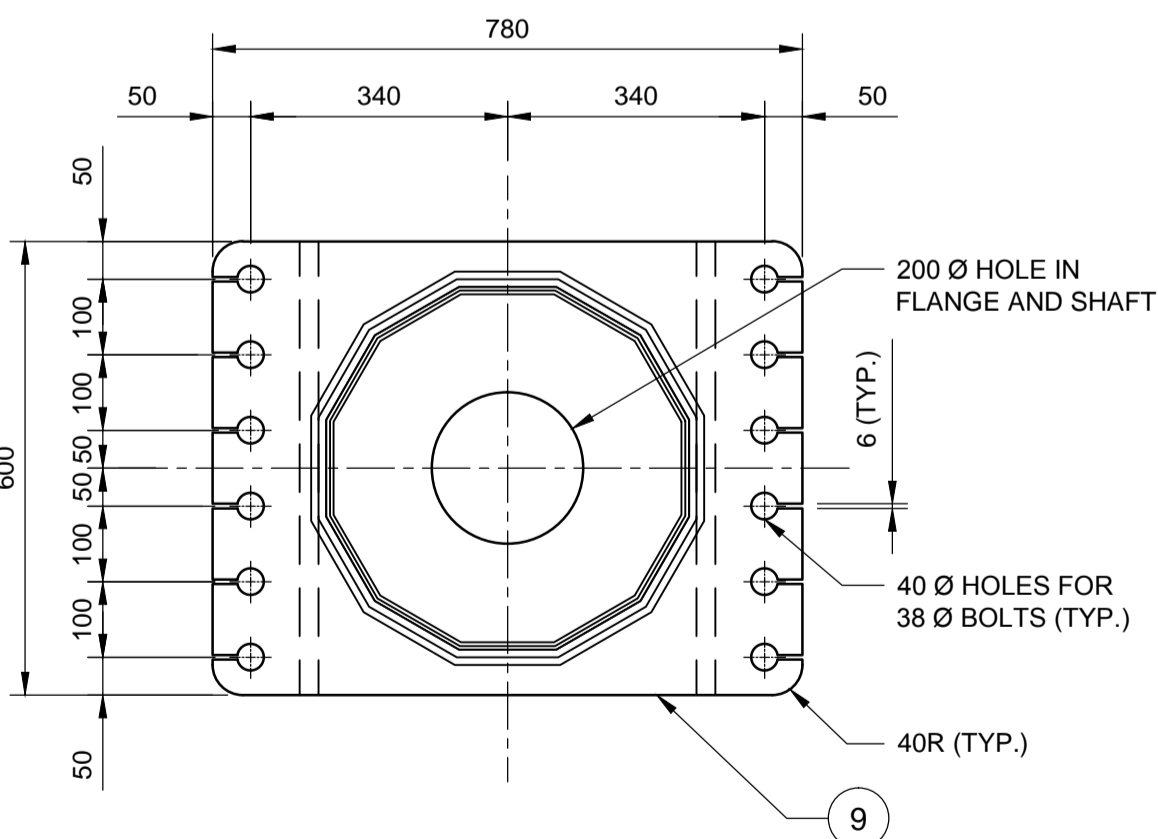

FLANGE PLATE DETAIL
NTS

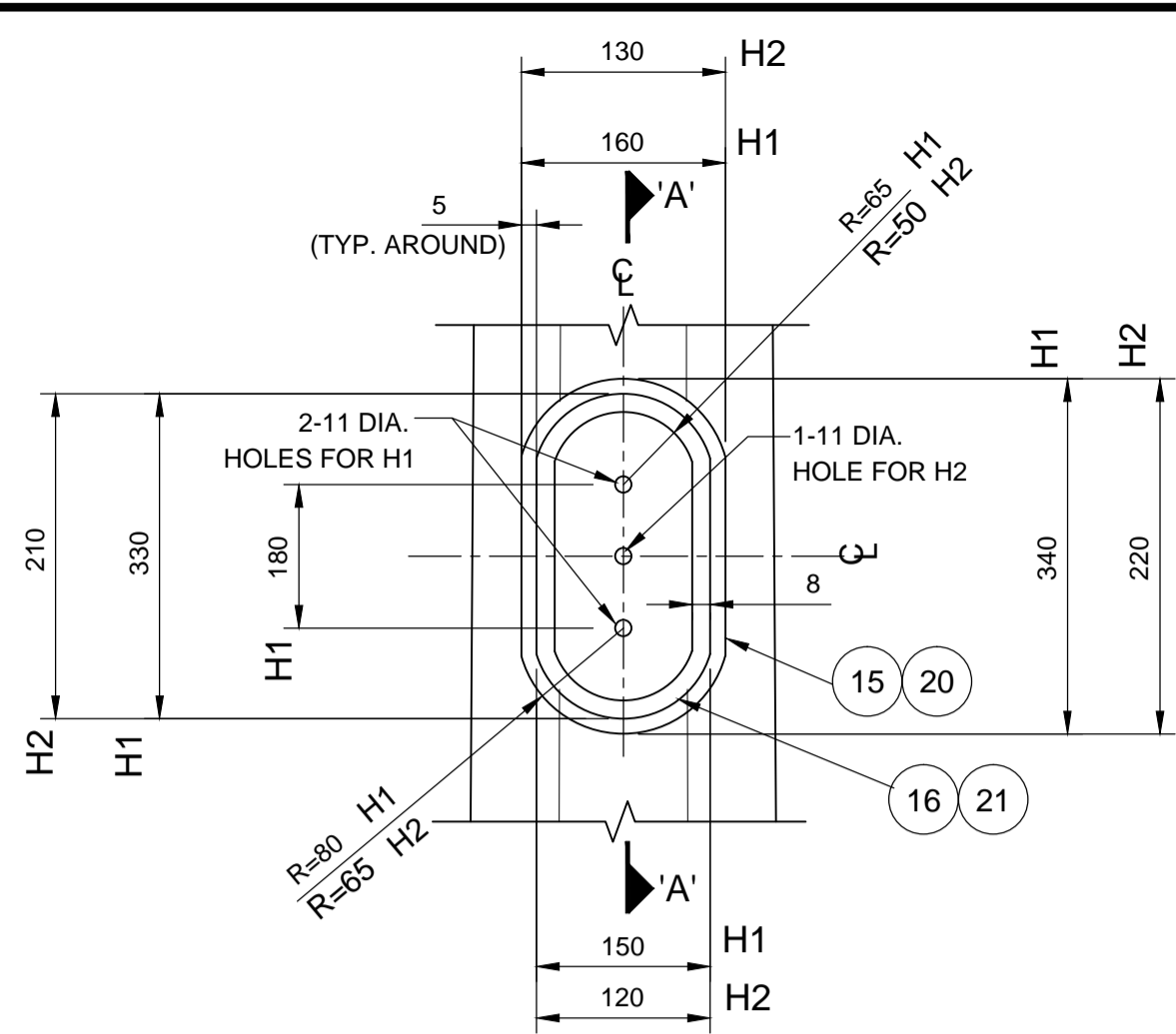

FRONT ELEVATION
NTS

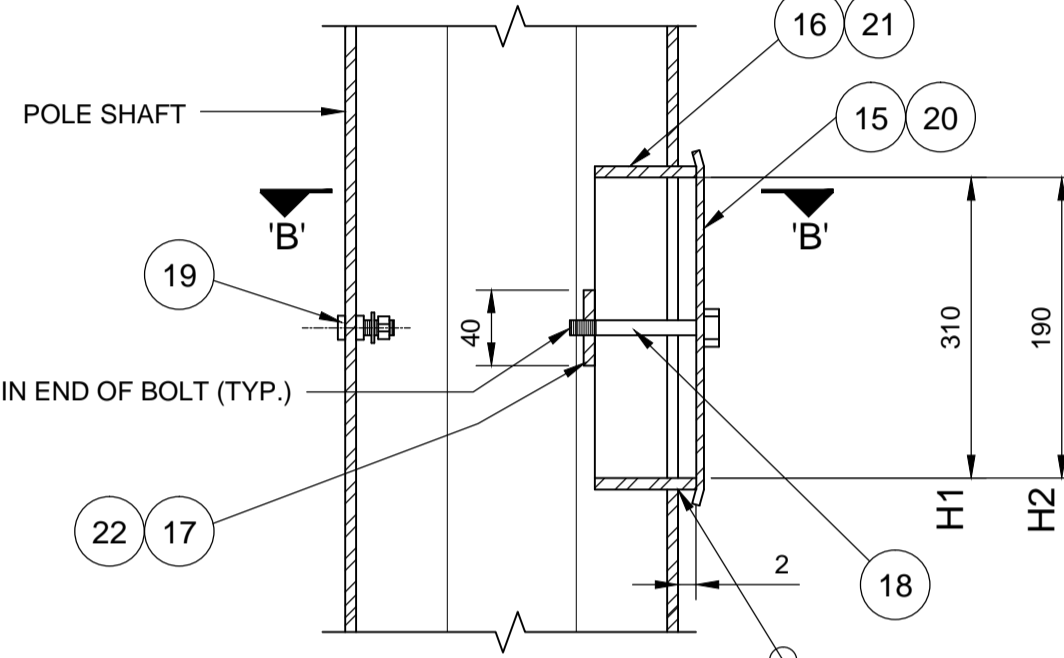

SECTION 'A-A'
NTS

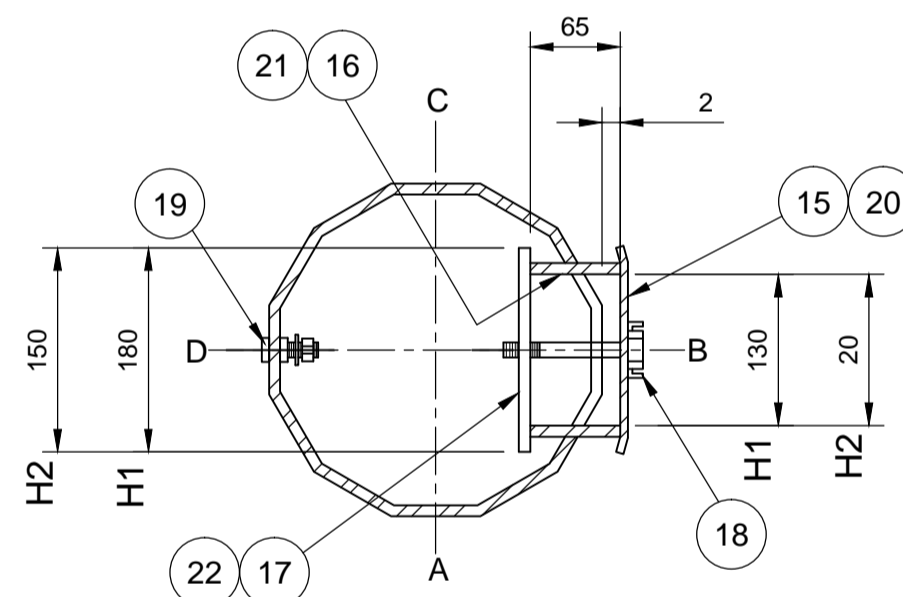

SECTION 'B-B'
NTS

HANDHOLE - MARK H1 & H2
NTS

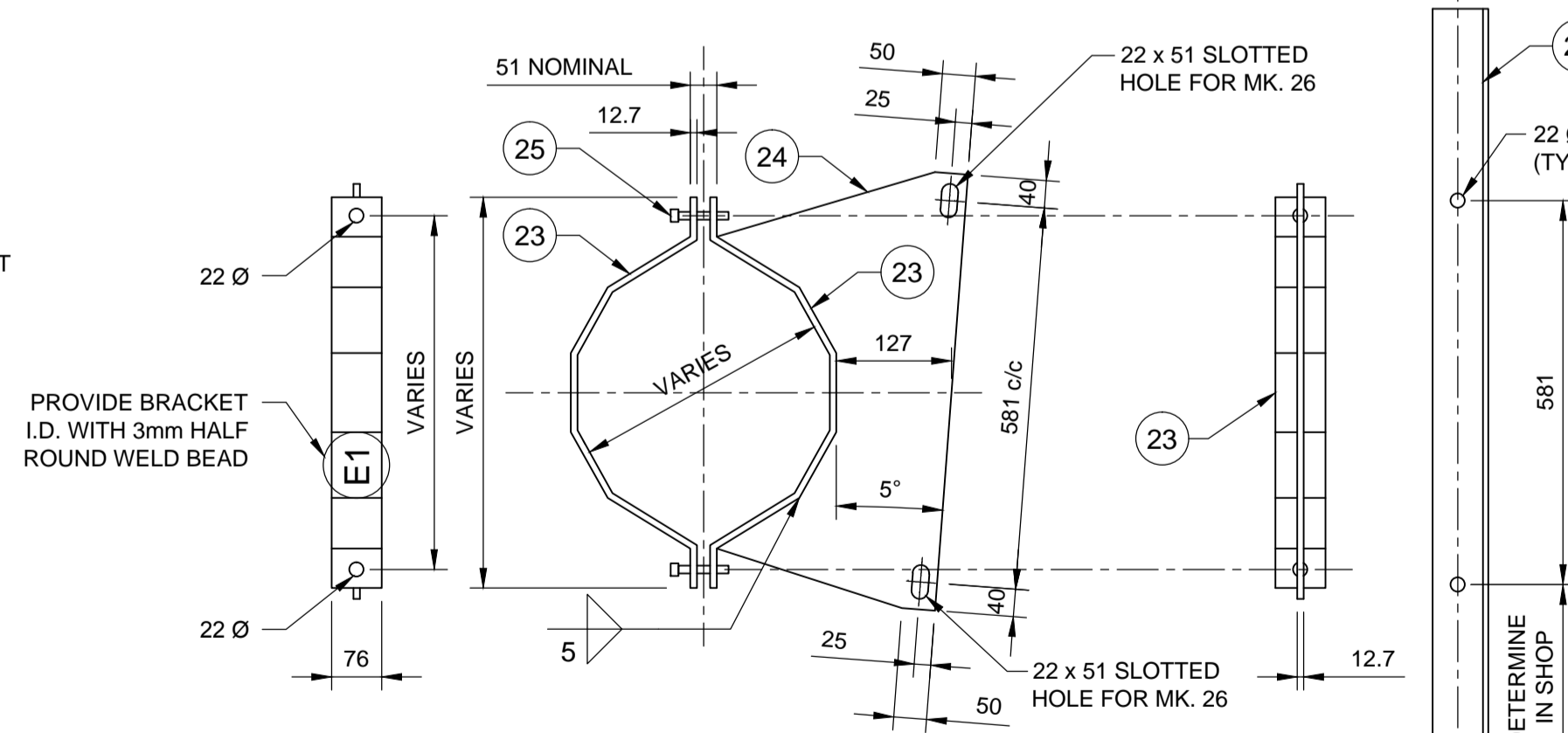

SIGN MOUNTING BRACKET DETAIL
NTS

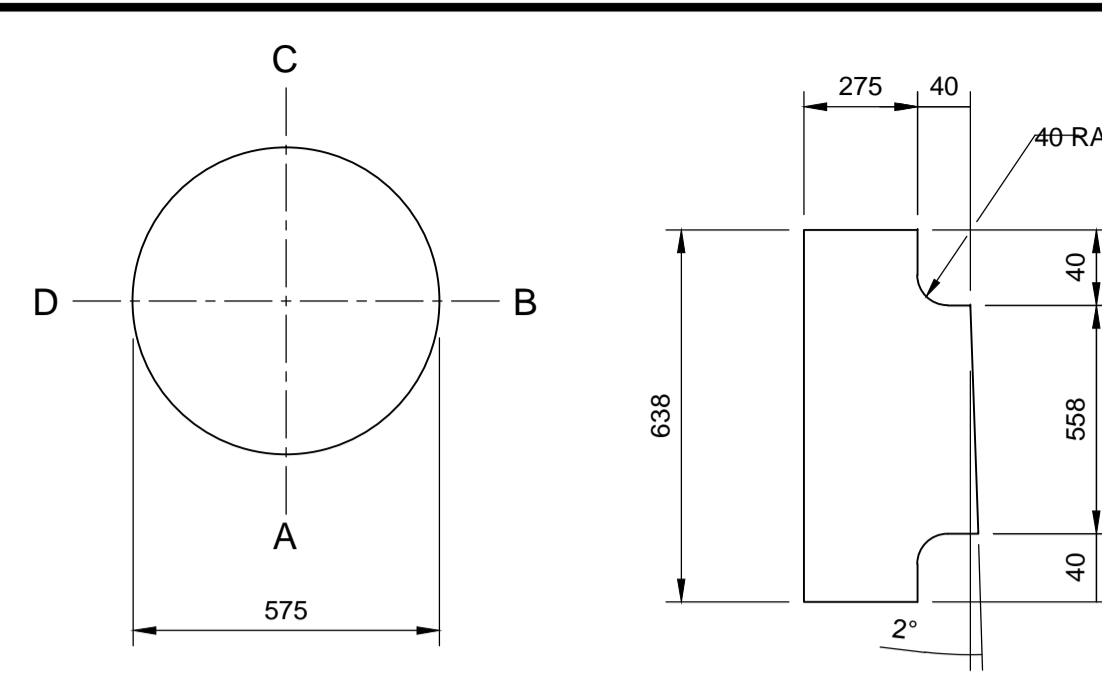

TOP PLATE - MARK 4
NTS

PLATE - MARK 11
NTS

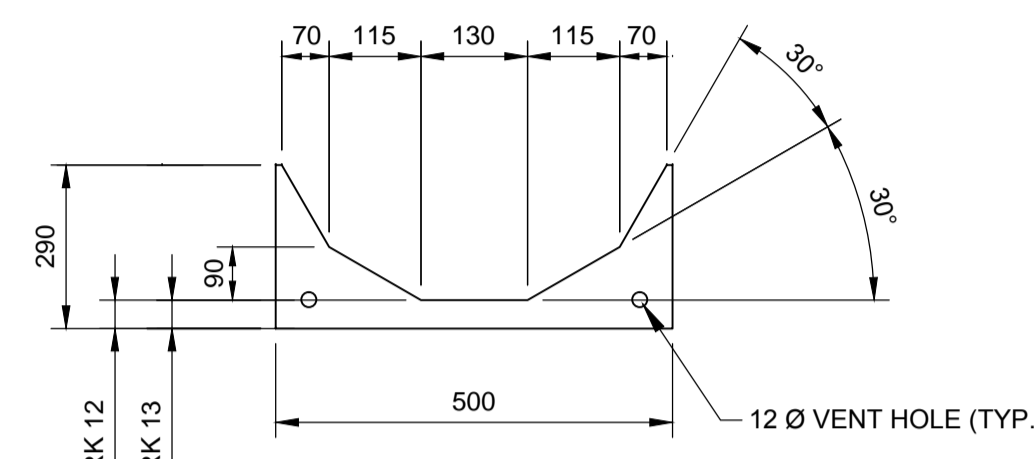

GUSSET PLATE - MARK 12 & 13
NTS

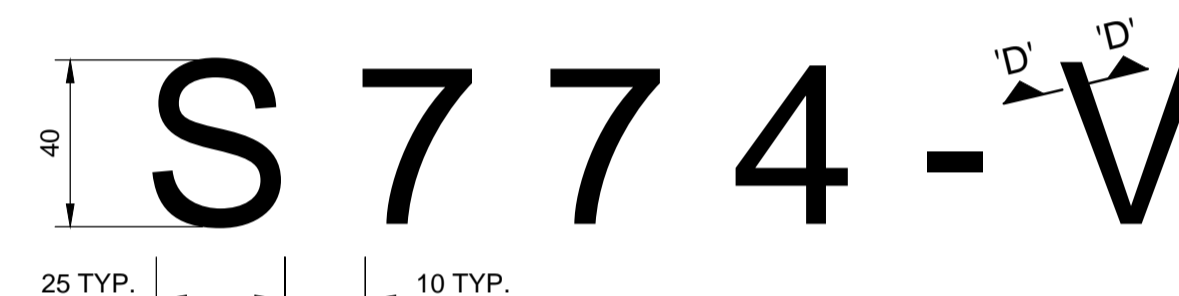

STRUCTURE IDENTIFICATION NUMBER SIZE
NTS

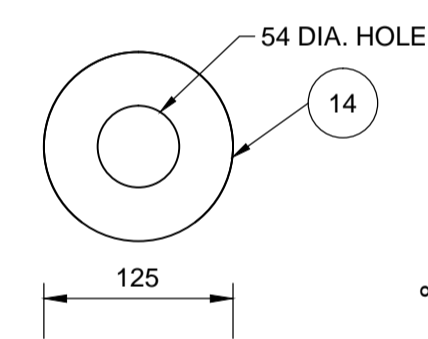

WASHER DETAIL
NTS

SECTION 'D-D'
NTS

GENERAL NOTES

1. DESIGN DATA

AASHTO STANDARD SPECIFICATIONS FOR STRUCTURAL SUPPORTS FOR HIGHWAY SIGNS, LUMINAIRES, AND TRAFFIC SIGNALS, 5TH EDITION, 2009, PLUS INTERIMS.

DESIGN WIND LOAD = 1.5 kPa

DESIGN ICE LOAD = 0.15 kPa

FATIGUE CATEGORY I CONSIDERING NATURAL WIND GUSTS AND TRUCK INDUCED GUSTS. FATIGUE CATEGORY II FOR GALLOPING.

ALL PLATE MATERIALS SHALL BE CSA G40.21 - 300W STRUCTURAL STEEL.

ALL MATERIALS EXCEPT STAINLESS STEEL AND ALUMINUM SHALL BE HOT-DIP GALVANIZED IN ACCORDANCE WITH ASTM A123 TO A MIN. NET RETENTION OF 610 gm².

ALL AREAS OF DAMAGED GALVANIZING SHALL BE REPAIRED WITH SPRAY-ON COATING CALLED 'ZINGA'.

5. SIGNS

1 SIGN PANEL, MAXIMUM SIZE 3962 x 2134 mm. SUPPLIED AND INSTALLED BY THE CITY OF WINNIPEG TRAFFIC SERVICES BRANCH.

INSTALL HOLES IN THE GUSSET PLATES FOR DRAINAGE DURING GALVANIZING AS DETAILED.

PROVIDE 'RAISED' IDENTIFICATION NO. WITH WELDING ELECTRODE FOR THE SIGN STRUCTURE.

GRIND ALL SHARP POINTS AND EDGES.

EXTERIOR WELD JOINING SHAFT TO TRANSVERSE PLATE SHALL BE AN UNEQUAL LEG COMPLETE PENETRATION WELD WITH THE LONG LEG OF THE WELD ALONG THE SHAFT TERMINATING AT 30° FROM THE SHAFT SURFACE.

BILL OF MATERIALS

MK.	QTY.	DESCRIPTION
1	1	DODECAGONAL SHAFT 500 A/F x 9.525 THICK PLATE
2	1	BACK-UP STRIP 40 x 4.763
3	1	BASE PLATE 850 DIA. x 51 THICK
4	1	TOP PLATE 12 THICK
5	2	DODECAGONAL GUSSET PLATE 12 THICK
6	1	DODECAGONAL ARM 500 A/F TO 200 A/F x 9.525 THICK PLATE
7	1	DODECAGONAL END PLATE 200 A/F x 4.763 THICK
8	1	BACK-UP STRIP 40 x 4.763
9	2	FLANGE PLATE 51 THICK
10	12	38 DIA. BOLTS C/W NUT & 2 WASHERS (ASTM A325)
11	2	SIDE GUSSET PLATE 25 THICK
12	1	GUSSET PLATE 19 THICK
13	1	GUSSET PLATE 19 THICK
14	16	PLATE WASHER 8 THICK
		HANDHOLE MARK H1
15	1	COVER PLATE 11 GA. x 160x 340 (ASTM A569)
16	1	REINFORCING RING 8 x 65 x 830
17	2	CLAMP BAR 6 x 40 x 180
18	2	10 DIA. x 140 BOLT S/S (TYPE 316)
19	1	GROUND STUD ASSEMBLY 10 DIA. x 40
		HANDHOLE MARK H2
20	1	COVER PLATE 11 GA. x 130 x 220 (ASTM A569)
21	1	REINFORCING RING 8 x 65 x 555
22	1	CLAMP BAR 6 x 40 x 150
18	1	10 DIA. x 140 BOLT S/S (TYPE 316)
19	1	GROUND STUD ASSEMBLY 10 DIA. x 40
		SIGN MOUNTING BRACKET (4 REQUIRED)
23	2	CLAMP BAR 12 x 76 (LENGTH TO SUIT)
24	1	BRACKET PLATE 12 THICK
25	2	19 DIA. BOLT C/W NUT & 2 WASHERS (ASTM A325)
26	2	19 DIA. S/S BOLT C/W NUT, 2 WASHERS & 1 LOCK WASHER (ASTM A193 GRADE B8)
27	1	ALUMINUM T-BAR 6061-T6 ASTM B221 102 x 76 x 8 LENGTH TO SUIT SIGN PANEL HEIGHT

* NOTES:

- MARK NO. 17 & 22 C/W 8-DIA. PUNCHED 10 N.C. TAPPED AT THE CENTER OF PLATE.
- MARK NO. 18 C/W CUP WASHER.
- MARK NO. 19 C/W 2-10 DIA. HEX NUT, 2-TERMINAL WASHER & 1-LOCKWASHER.



METRIC

WHOLE NUMBERS INDICATE MILLIMETRES
DECIMALIZED NUMBERS INDICATE METRES

WARNING

IF POWER EQUIPMENT OR EXPLOSIVES ARE TO BE USED FOR EXCAVATION ON THIS PROJECT THE CONTRACTOR MUST:

- NOTIFY THE GAS COMPANY OF THE PROPOSED LOCATION OF EXCAVATION.
- TAKE PRECAUTION TO AVOID DAMAGE TO GAS COMPANY INSTALLATIONS SEE PROVINCIAL REGULATION 210/72 FOR DETAILS.
- OBTAIN EXCAVATION PERMITS PRIOR TO CONSTRUCTION.
- A MINIMUM VERTICAL SEPARATION OF 300 mm FROM GAS MAINS AND 100 mm FROM GAS SERVICE MUST BE MAINTAINED BETWEEN ANY MANITOBA HYDRO FACILITY AND ANY NEW INSTALLATIONS.
- A MINIMUM 900 mm OF COVER SHALL BE MAINTAINED IN ALL AREAS WHERE EQUIPMENT WILL BE CROSSING, TRAVELING OR COMPACTING OVER THE HIGH PRESSURE GAS MAINS.
- IF EQUIPMENT MUST CROSS, TRAVEL, OR COMPACT OVER THE GAS MAIN WITH LESS THAN THE MINIMUM DEPTH COVER, EARTH BRIDGING OR STEEL PLATES SHALL BE PLACED OVER THE MAIN AND EXTEND A MINIMUM OF 1.0 METRE ON EITHER SIDE AT EACH CROSSING LOCATION.

C:\CAD\126606\Contract_2\Current\126606-CONTRACT_2-0HSS-122.dwg

150 WM	WATERMAIN	150 WM	M.T.S.	M.T.S.	150 mm W.M.	WATERMAIN	150 mm W.M.
+	HYDRANT	+			+	HYDRANT	+
+	VALVE	+			+	VALVE	+
300 LDS	LAND DRAINAGE SEWER	300 LDS			300 mm L.D.S.	LAND DRAINAGE SEWER	300 mm L.D.S.
250 WWS	WASTE WATER SEWER	250 WWS			250 mm W.W.S.	WASTE WATER SEWER	250 mm W.W.S.
○	MANHOLE	○			○	MANHOLE	○
○	CATCH BASIN	○			○	CATCH BASIN	○
○	TEST HOLES	○			○	TEST HOLES	○
+	JUNCTIONS	+			+	JUNCTIONS	+
+	CULVERT	+			+	CULVERT	+
100 GAS	GAS	100 GAS			100 GAS	GAS	100 GAS
EXISTING	LEGEND-PLAN	PROPOSED	EXISTING	LEGEND-PLAN	PROPOSED	EXISTING	LEGEND-PROFILE

UNDERGROUND STRUCTURES

SUPV. U/G STRUCTURES COMMITTEE DATE

NOTE:
LOCATION OF UNDERGROUND STRUCTURES AS SHOWN ARE BASED ON THE BEST INFORMATION AVAILABLE, BUT NO GUARANTEE IS GIVEN THAT ALL EXISTING UTILITIES ARE SHOWN OR THAT THE GIVEN LOCATIONS ARE EXACT. CONFIRMATION OF EXISTENCE AND EXACT LOCATION OF ALL SERVICES MUST BE OBTAINED FROM THE INDIVIDUAL UTILITIES BEFORE PROCEEDING WITH CONSTRUCTION.

B.M.	654008	N: 5515764.610	E: 633359.697	654210	N: 5514436.957	E: 630550.534
ELEV.	232.463	m				
DESIGNED BY	CDW					
DRAWN BY	LFY					
CHECKED BY	SSR					
APPROVED BY	DPK					
HOR. SCALE	AS NOTED					
VERTICAL	AS NOTED					
0	ISSUED FOR TENDER	13/08/08	MRD			
NO.	REVISIONS	DATE	BY	DATE		

DESIGN TEAM
DILLON CONSULTING

ENGINEER'S SEAL
PROVINCE OF MANITOBA C.D. WARD Member 24456 REGISTERED PROFESSIONAL ENGINEER

THE CITY OF WINNIPEG PUBLIC WORKS DEPARTMENT
WAVERLEY WEST ARTERIAL ROADS PROJECT (WVARP) PART 3 - CONTRACT 2 ROUTE 90 TO ROUTE 165 OVERPASS (KENASTON BLVD.) AND ASSOCIATED WORKS
CITY DRAWING NUMBER B242-13-123
SHEET 123 OF 128
CONSULTANT PROJECT NUMBER 12-6606

CONSULTANT DRAWING NUMBER
S774 - FABRICATION DETAILS
S774-2013-02