

ALLEY PAVEMENT PROFILE
SCALE: 1:250 HOR
1:10 VER

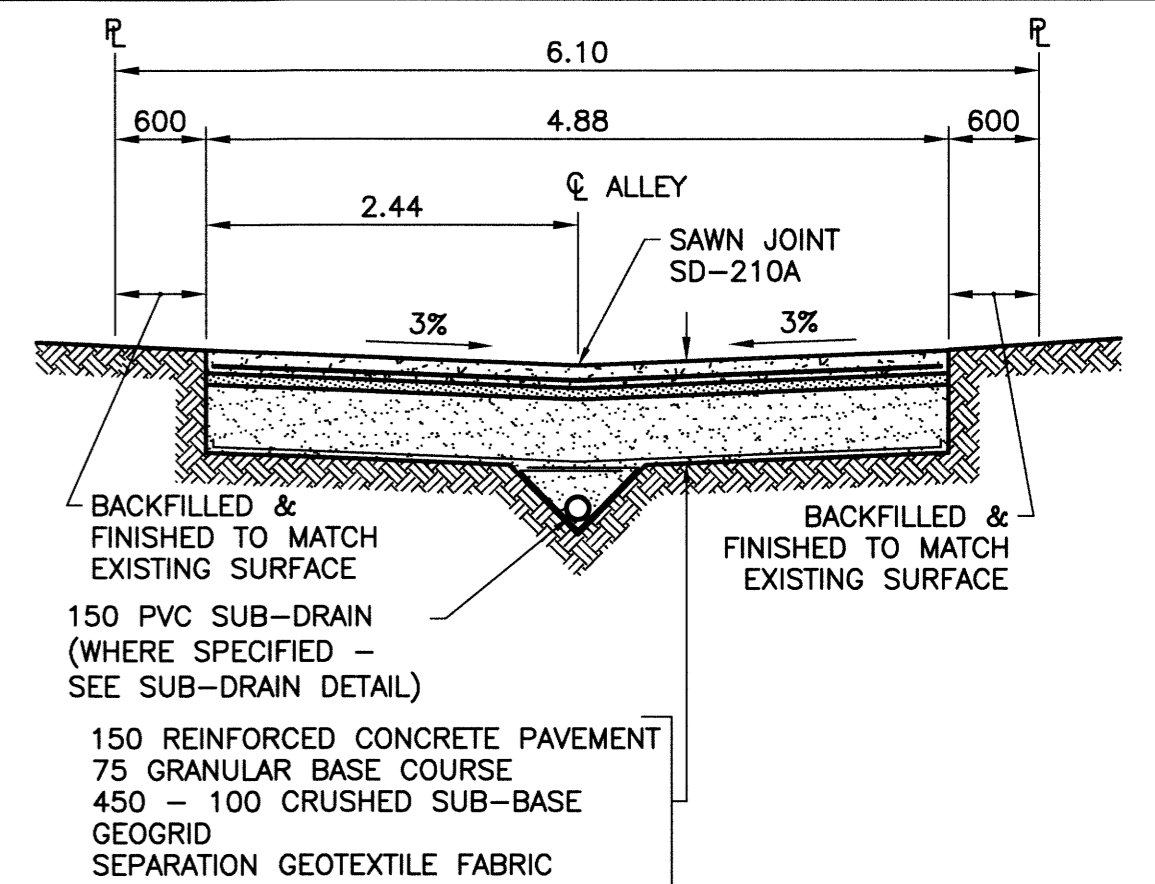

TYPICAL CROSS SECTION
SCALE: 1:50

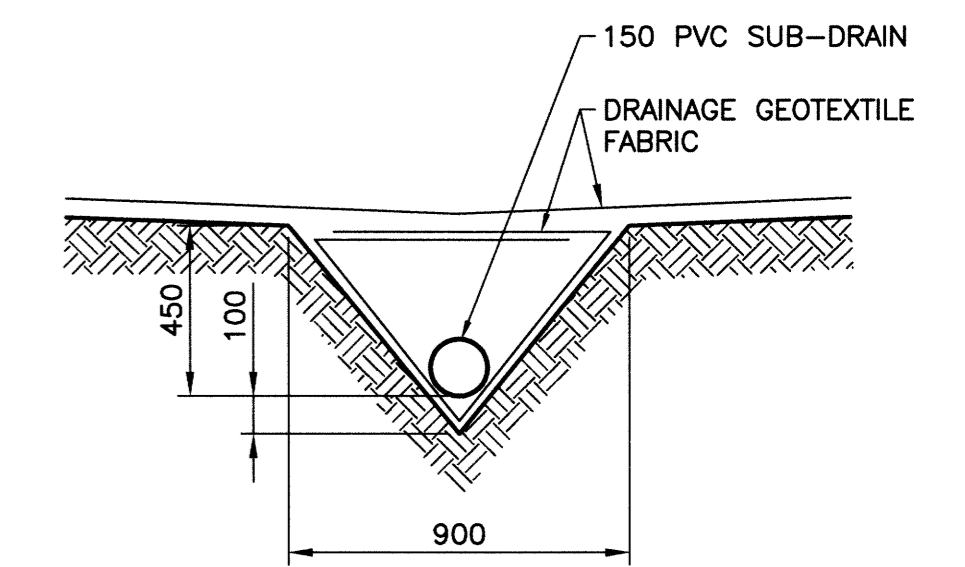

SUB-DRAIN DETAIL
SCALE: 1:20

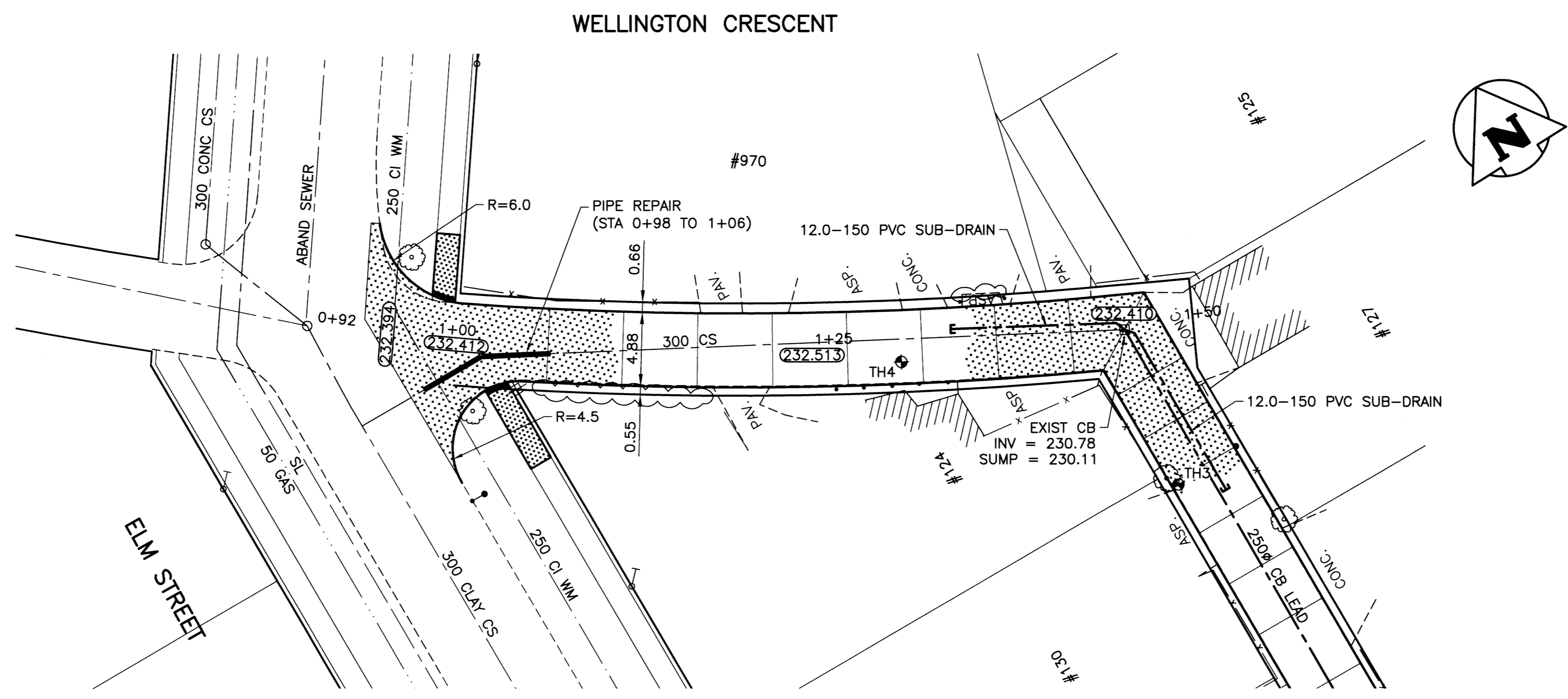

ALLEY PAVEMENT PLAN
SCALE: 1:250 HOR

- NOTES:**
1. STATION CHAINAGE IS BASED ON CENTERLINE OF ALLEY RIGHT OF WAY.
 2. ADJUST MH AND CB RIMS TO NEW GRADES.
 3. PLUG SUB-DRAINS AT TERMINAL ENDS.
 4. REGRADE EXISTING PRIVATE SIDEWALKS AS REQUIRED.
 5. INSTALLATION OF LIP CURBS AND THEIR EXTENTS TO BE DETERMINED BY THE CONTRACT ADMINISTRATOR.
 6. LIGHT STANDARDS, HYDRO POLES AND ANCHORS MAY REQUIRE TEMPORARY SUPPORT/REMOVAL OR REPLACEMENT AT THE CONTRACTOR'S EXPENSE.
 7. ISOLATE ALL POLES, BASES AND PILES WITHIN ALLEY RIGHT OF WAY (SD-228C)
 8. AVOID DAMAGE TO EXISTING TREES WITHIN THE LIMITS OF CONSTRUCTION
 9. CITY OF WINNIPEG SURVEY MONUMENTS EXIST ON THIS SITE. CONTRACTOR TO CONTACT THE CITY OF WINNIPEG GEOMATICS BRANCH 5 WORKING DAYS IN ADVANCE OF CONSTRUCTION TO COORDINATE MONUMENT PROTECTION SERVICES (204-918-1360)

WARNING
NOTIFY THE GAS COMPANY OF THE PROPOSED LOCATION OF EXCAVATION. TAKE PRECAUTION TO AVOID DAMAGE TO GAS COMPANY INSTALLATIONS. SEE PROVINCIAL REGULATION 210/72 FOR DETAILS.

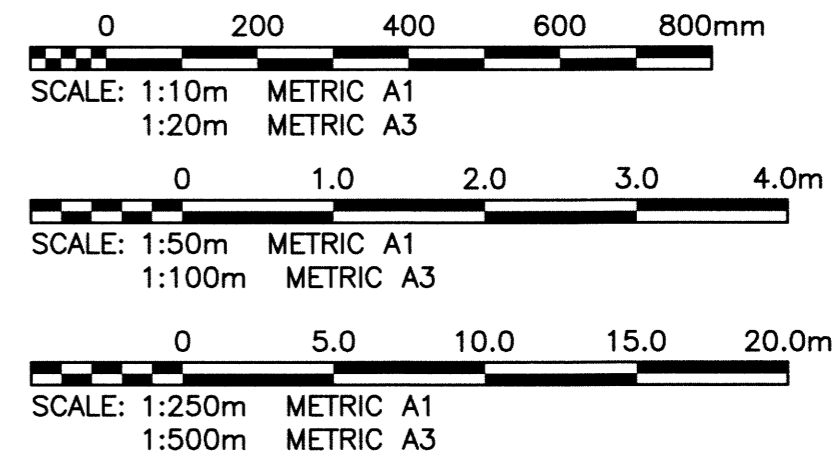

METRIC
WHOLE NUMBERS INDICATE MILLIMETRES
DECIMALIZED NUMBERS INDICATE METRES

PROPERTY LIMITS DELINEATION
DELINEATION OF PROPERTY LIMITS AS SHOWN ON THIS DWG DOES NOT REPRESENT A "LEGAL SURVEY". KGS GROUP MAKES NO REPRESENTATION OR WARRANTY AS TO THE ACCURACY OF PROPERTY LIMITS DELINEATED ON THIS DWG, NOR ON THE DIMENSIONAL ACCURACY OF DWG FEATURES RELATIVE TO THOSE PROPERTY LIMITS.



300 LBS	LAND DRAINAGE SEWER	300 LBS					
250 WWS	WASTE WATER SEWER	250 WWS	TEST HOLE				
	GAS		GUY WIRE				
	HYDRO		LIGHT STANDARD				
	M.T.S.		BACK OF CURB				
150 WM	WATERMAIN	150 WM	CONCRETE				
	HYDRANT		ASPHALT				
	VALVE		SIDEWALK				
	MANHOLE		PROPERTY LINE				
	CATCH BASIN		SURVEY BAR				
	CURB INLET		GEODETIC BENCHMARK				
	POLES T-HYDRO		ELEVATION	231.334			
EXISTING	LEGEND-PLAN	PROPOSED	EXISTING	LEGEND-PLAN	PROPOSED	EXISTING	LEGEND-PROFILE

LOCATION APPROVED UNDERGROUND STRUCTURES

SUPV. U/G STRUCTURES COMMITTEE DATE

NOTE:
LOCATION OF UNDERGROUND STRUCTURES AS SHOWN ARE BASED ON THE BEST INFORMATION AVAILABLE BUT NO GUARANTEE IS GIVEN THAT ALL EXISTING UTILITIES ARE SHOWN OR THAT THE GIVEN LOCATIONS ARE EXACT. CONFIRMATION OF EXISTENCE AND EXACT LOCATION OF ALL SERVICES MUST BE OBTAINED FROM THE INDIVIDUAL UTILITIES BEFORE PROCEEDING WITH CONSTRUCTION.

B.M. 51-040
ELEV. 232.591

N.W. Cor. Academy Rd. & Elm St., 19mm x 6.2m I.B. in Valve Box, 2.1m E. of W.L. Elm St. & 0.2m N. of N.L. Academy Rd.

DESIGNED BY: RBO
DRAWN BY: GEL
HOR. SCALE: 1:250
VERTICAL: 1:50

ISSUED FOR TENDER: 13/06/25
NO. REVISIONS: 0
DATE: 13/06/12

KGS GROUP
CONSULTING ENGINEERS

ENGINEER'S SEAL
PROVINCE OF MANITOBA
R.B. OFFMAN
Member
2577

DESIGNED BY: RBO
CHECKED BY: CR
DRAWN BY: GEL
APPROVED BY:
HOR. SCALE: 1:250
VERTICAL: 1:50
RELEASED FOR CONSTRUCTION:
DATE: 13/06/12

CONSULTANT DRAWING NO. 13-0107-007_C05

THE CITY OF WINNIPEG
PUBLIC WORKS DEPARTMENT
TRANSPORTATION ENGINEERING DIVISION

PROJECT TITLE: 2013 ALLEY RENEWAL PROGRAM
CONTRACT 1
WELLINGTON CR SOUTH
ELM STREET TO STA 1+44.17

SHEET OF 05 OF 16
COMPUTER FILE NAME: 13-0107-007_CALL
CITY DRAWING NUMBER: 0005

P:\Projects\2013\13-0107-007\DocControl\Tobiasseue\DWG\13-0107-007_C05-Rev 0.dwg - Tab: 05 Plotted By: Guewen 06/19/2013 [Wed 7:10am] PLOT: 1:1: A-1