

ALLEY PAVEMENT PROFILE
SCALE: 1:250 HOR
1:10 VER

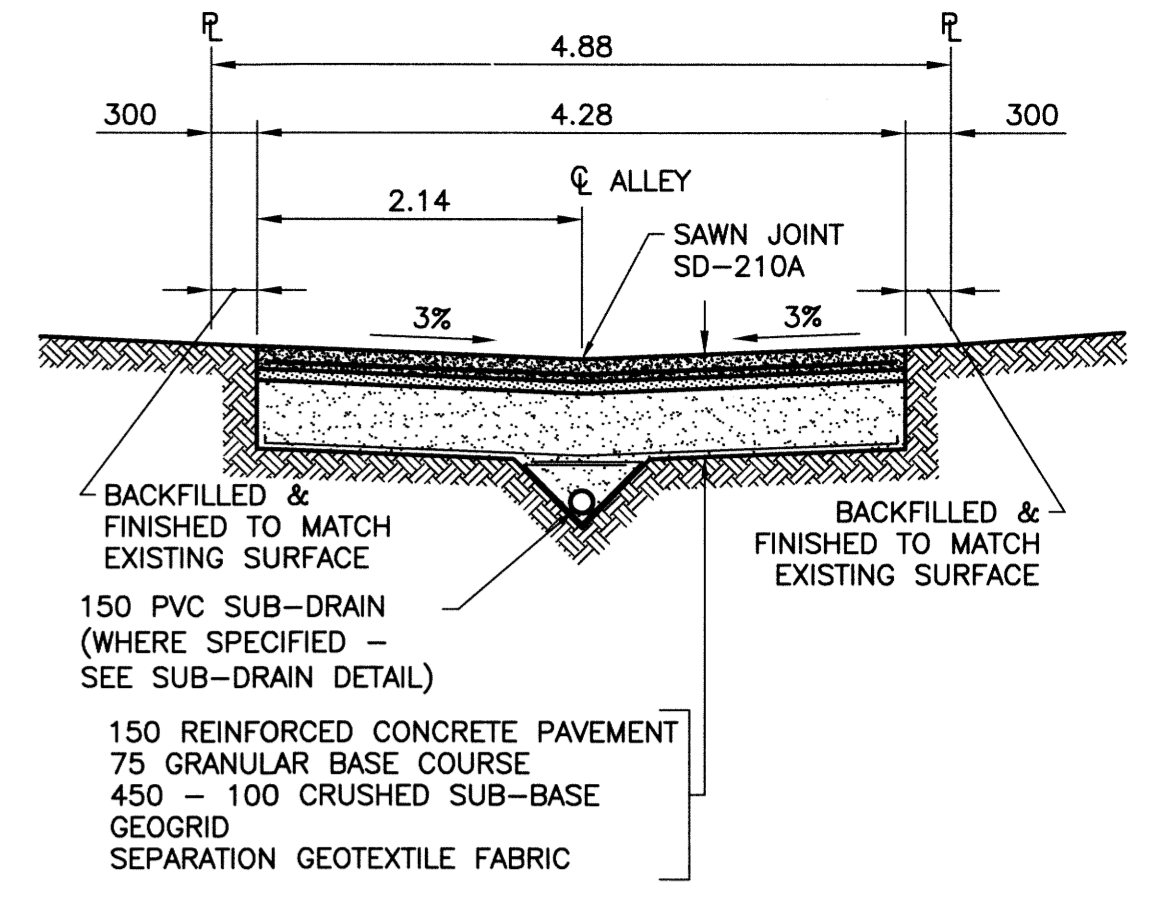

TYPICAL CROSS SECTION
SCALE: 1:50

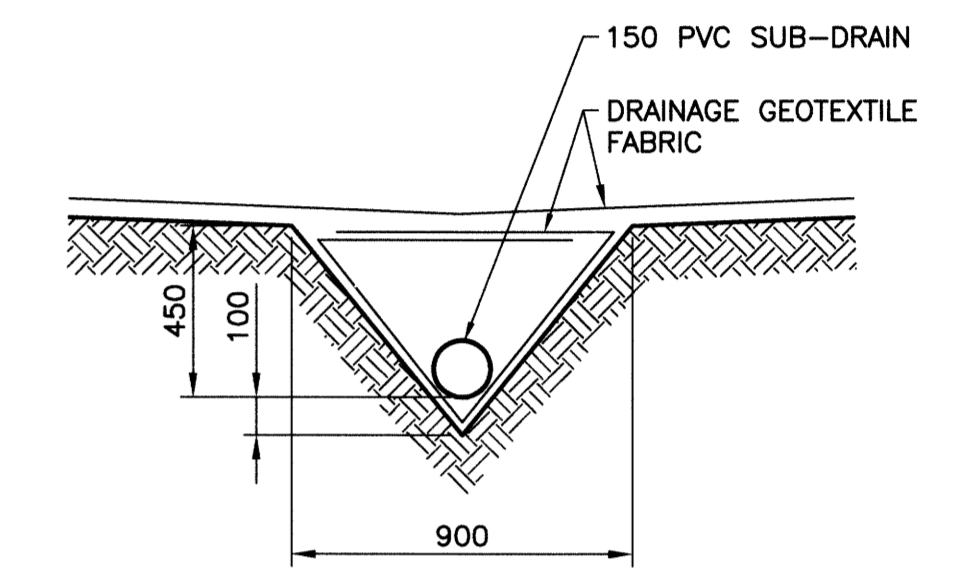

SUB-DRAIN DETAIL
SCALE: 1:20

GARFIELD STREET

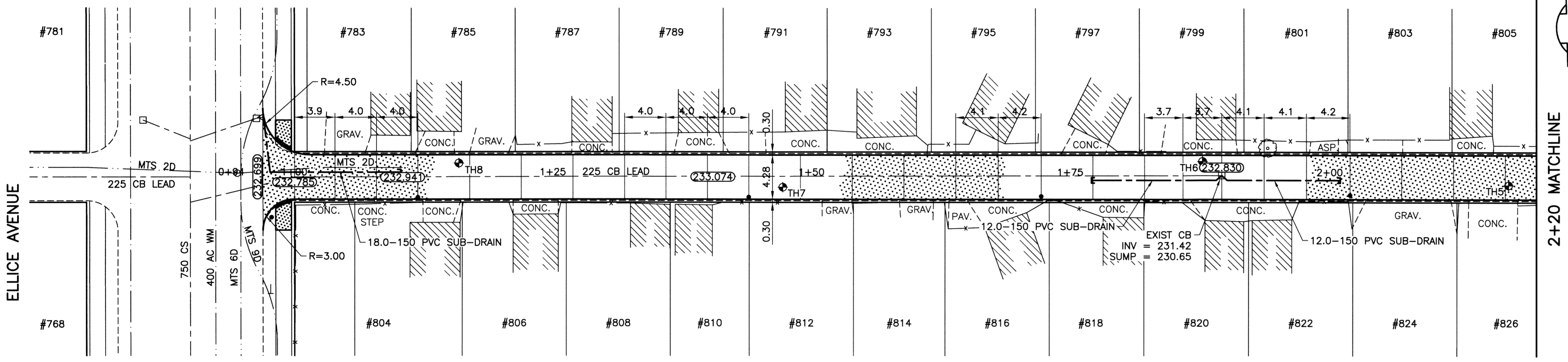

ALLEY PAVEMENT PLAN
SCALE: 1:250 HOR

- NOTES:**
1. STATION CHAINAGE IS BASED ON CENTERLINE OF ALLEY RIGHT OF WAY.
 2. ADJUST MH AND CB RIMS TO NEW GRADES.
 3. PLUG SUB-DRAINS AT TERMINAL ENDS.
 4. REGRADE EXISTING PRIVATE SIDEWALKS AS REQUIRED.
 5. INSTALLATION OF LIP CURBS AND THEIR EXTENTS TO BE DETERMINED BY THE CONTRACT ADMINISTRATOR.
 6. LIGHT STANDARDS, HYDRO POLES AND ANCHORS MAY REQUIRE TEMPORARY SUPPORT/REMOVAL OR REPLACEMENT AT THE CONTRACTOR'S EXPENSE.
 7. ISOLATE ALL POLES, BASES AND PILES WITHIN ALLEY RIGHT OF WAY (SD-228C)
 8. AVOID DAMAGE TO EXISTING TREES WITHIN THE LIMITS OF CONSTRUCTION.

WARNING
NOTIFY THE GAS COMPANY OF THE PROPOSED LOCATION OF EXCAVATION. TAKE PRECAUTION TO AVOID DAMAGE TO GAS COMPANY INSTALLATIONS. SEE PROVINCIAL REGULATION 210/72 FOR DETAILS.

METRIC
WHOLE NUMBERS INDICATE MILLIMETRES
DECIMALIZED NUMBERS INDICATE METRES

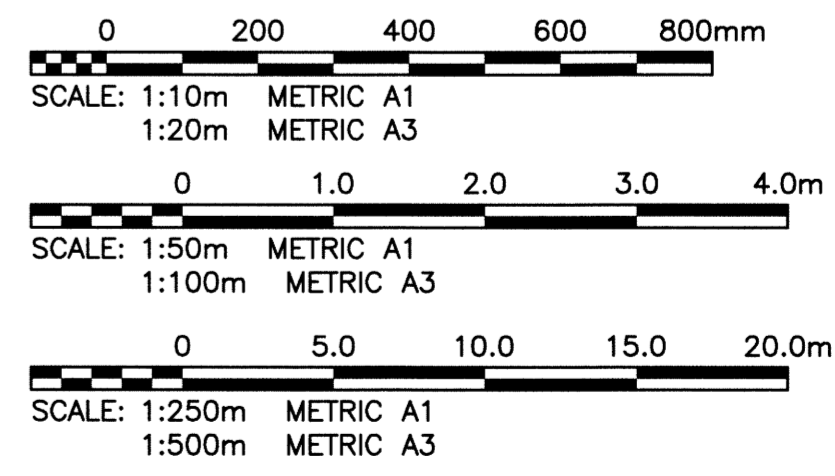

PROPERTY LIMITS DELINEATION
DELINEATION OF PROPERTY LIMITS AS SHOWN ON THIS DWG DOES NOT REPRESENT A "LEGAL SURVEY". KGS GROUP MAKES NO REPRESENTATION OR WARRANTY AS TO THE ACCURACY OF PROPERTY LIMITS DELINEATED ON THIS DWG, NOR ON THE DIMENSIONAL ACCURACY OF DWG FEATURES RELATIVE TO THOSE PROPERTY LIMITS.



300 LBS	LAND DRAINAGE SEWER	300 LBS							
250 WWS	WASTE WATER SEWER	250 WWS							
	GAS								
	HYDRO								
	M.T.S.								
150 WM	WATERMAIN	150 WM							
	HYDRANT								
	VALVE								
	MANHOLE								
	CATCH BASIN								
	CURB INLET								
	POLES								
EXISTING	LEGEND-PLAN	PROPOSED	EXISTING	LEGEND-PLAN	PROPOSED	EXISTING	LEGEND-PROFILE	PROPOSED	

LOCATION APPROVED UNDERGROUND STRUCTURES

SUPV. U/G STRUCTURES COMMITTEE DATE

NOTE:
LOCATION OF UNDERGROUND STRUCTURES AS SHOWN ARE BASED ON THE BEST INFORMATION AVAILABLE BUT NO GUARANTEE IS GIVEN THAT ALL EXISTING UTILITIES ARE SHOWN OR THAT THE GIVEN LOCATIONS ARE EXACT. CONFIRMATION OF EXISTENCE AND EXACT LOCATION OF ALL SERVICES MUST BE OBTAINED FROM THE INDIVIDUAL UTILITIES BEFORE PROCEEDING WITH CONSTRUCTION.

B.M. 36-061	N.W. Cor. Sargent Ave. & Garfield St. N. Tblt. in S. Conc. Foundation of Sargent Ave. Mennonite Church, 0.5m W. & 1.7m below brick of S.E. Cor. of Bldg.
ELEV. 233.373	
NO.	REVISIONS
0	ISSUED FOR TENDER
13/06/25	DATE
RBO	BY

KGS GROUP CONSULTING ENGINEERS

Certificate of Authorization
KGS Group
No. 245

DESIGNED BY	RBO	CHECKED BY	CR
DRAWN BY	GEL	APPROVED BY	
HOR. SCALE:	1:250	RELEASED FOR CONSTRUCTION:	
VERTICAL:	1:50	DATE	13/06/12

ENGINEER'S SEAL

THE CITY OF WINNIPEG
PUBLIC WORKS DEPARTMENT
TRANSPORTATION ENGINEERING DIVISION

PROJECT TITLE
2013 ALLEY RENEWAL PROGRAM
CONTRACT 1
GARFIELD ST/SHERBURN ST
ELLICE AVE TO SARGENT AVE
ELLICE AVE TO STA 2+20

SHEET OF
06 OF **16**

COMPUTER FILE NAME
13-0107-007_CALL

CITY DRAWING NUMBER
0006

CONSULTANT DRAWING NO.
13-0107-007_C06

P:\Projects\2013\13-0107-007\Doc\Control\Tobias\DWG\13-0107-007_C06-Rev 0.dwg - Tab: 06 Plotted By: Gleenew 06/19/2013 [Wed 7:11am]