

ALLEY PAVEMENT PROFILE

SCALE: 1:250 HOR
1:10 VER

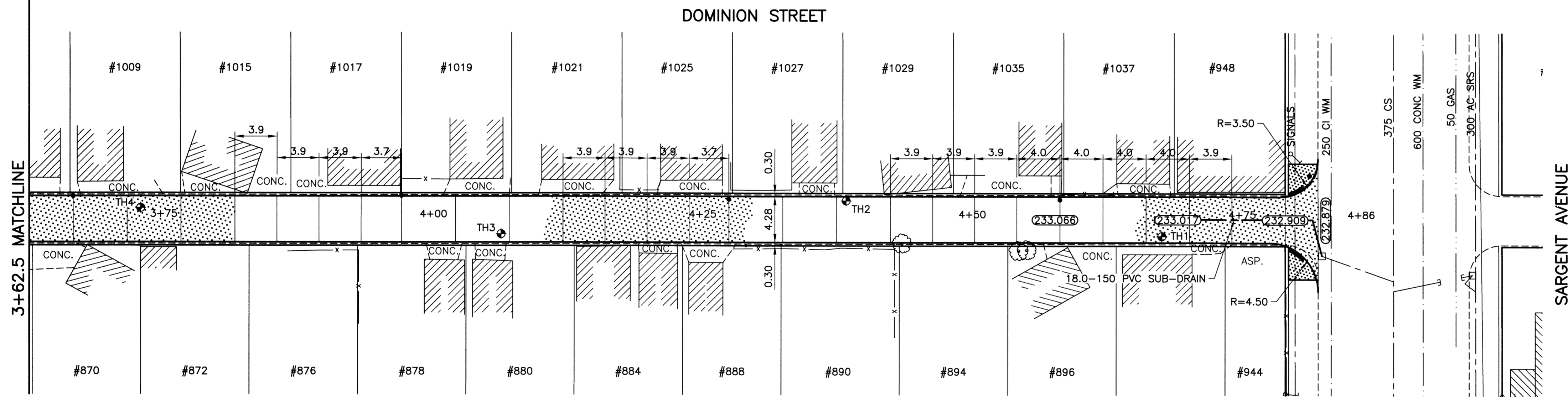

ALLEY PAVEMENT PLAN

SCALE: 1:250 HOR

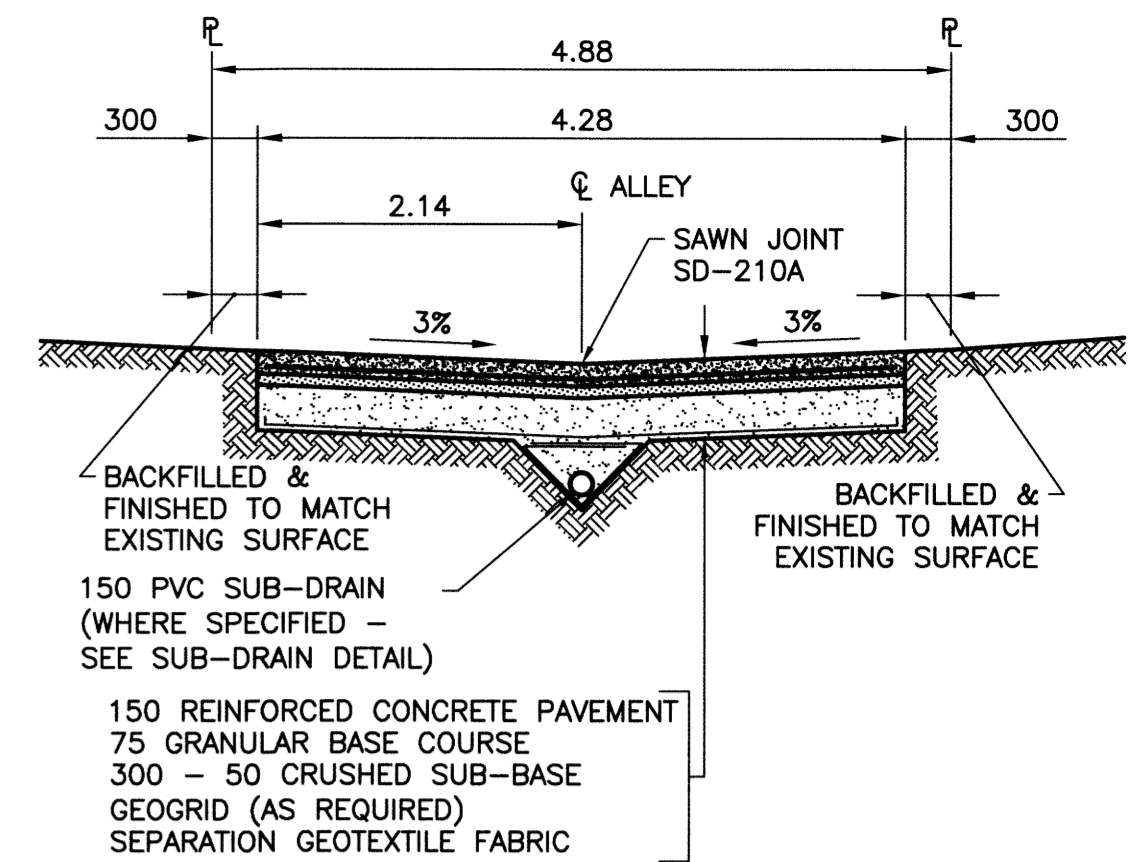

TYPICAL CROSS SECTION

SCALE: 1:50

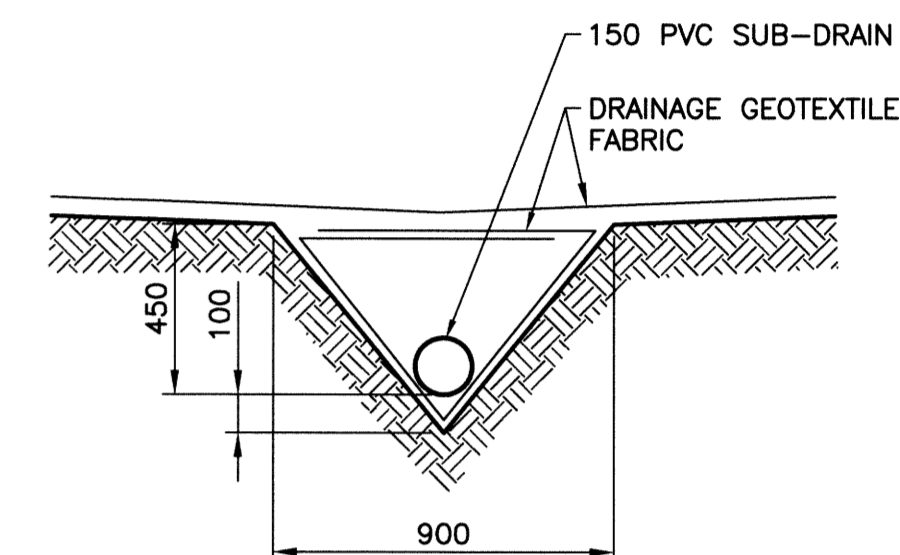

SUB-DRAIN DETAIL

SCALE: 1:20

NOTES:

- STATION CHAINAGE IS BASED ON CENTERLINE OF ALLEY RIGHT OF WAY.
- ADJUST MH AND CB RIMS TO NEW GRADES.
- PLUG SUB-DRAINS AT TERMINAL ENDS.
- REGRADE EXISTING PRIVATE SIDEWALKS AS REQUIRED.
- INSTALLATION OF LIP CURBS AND THEIR EXTENTS TO BE DETERMINED BY THE CONTRACT ADMINISTRATOR.
- LIGHT STANDARDS, HYDRO POLES AND ANCHORS MAY REQUIRE TEMPORARY SUPPORT/REMOVAL OR REPLACEMENT AT THE CONTRACTOR'S EXPENSE.
- ISOLATE ALL POLES, BASES AND PILES WITHIN ALLEY RIGHT OF WAY (SD-228C)
- AVOID DAMAGE TO EXISTING TREES WITHIN THE LIMITS OF CONSTRUCTION.

WARNING

NOTIFY THE GAS COMPANY OF THE PROPOSED LOCATION OF EXCAVATION. TAKE PRECAUTION TO AVOID DAMAGE TO GAS COMPANY INSTALLATIONS. SEE PROVINCIAL REGULATION 210/72 FOR DETAILS.

METRIC

WHOLE NUMBERS INDICATE MILLIMETRES
DECIMALIZED NUMBERS INDICATE METRES

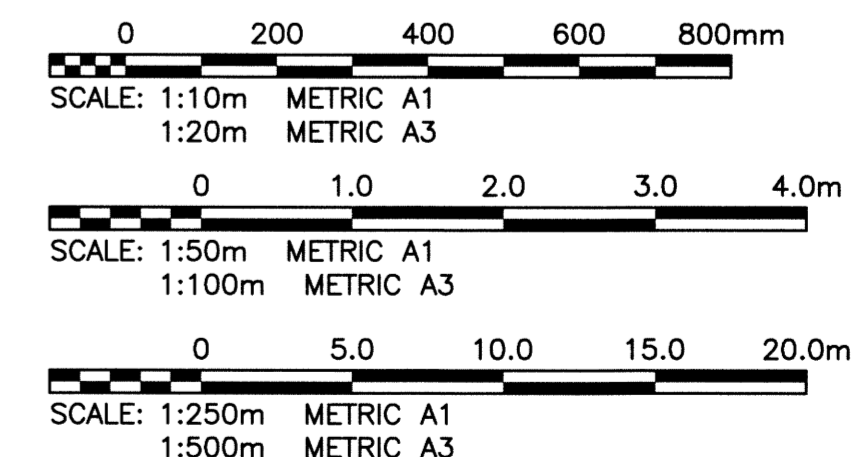

300 LDS	LAND DRAINAGE SEWER	300 LDS	TEST HOLE				
250 WWS	WASTE WATER SEWER	250 WWS	GUY WIRE				
	GAS		LIGHT STANDARD				
	HYDRO		BACK OF CURB				
	M.T.S.		CONCRETE				
150 WM	WATERMAIN	150 WM	ASPHALT				
	HYDRANT		SIDEWALK				
	VALVE		PROPERTY LINE				
	MANHOLE		SURVEY BAR				
	CATCH BASIN		GEODETIC BENCHMARK				
	CURB INLET		ELEVATION				
	POLES						
EXISTING	LEGEND-PLAN	PROPOSED	EXISTING	LEGEND-PLAN	PROPOSED	EXISTING	LEGEND-PROFILE

LOCATION APPROVED UNDERGROUND STRUCTURES

SUPV. U/G STRUCTURES COMMITTEE DATE

NOTE:
LOCATION OF UNDERGROUND STRUCTURES AS SHOWN ARE BASED ON THE BEST INFORMATION AVAILABLE BUT NO GUARANTEE IS GIVEN THAT ALL EXISTING UTILITIES ARE SHOWN OR THAT THE GIVEN LOCATIONS ARE EXACT. CONFIRMATION OF EXISTENCE AND EXACT LOCATION OF ALL SERVICES MUST BE OBTAINED FROM THE INDIVIDUAL UTILITIES BEFORE PROCEEDING WITH CONSTRUCTION.

B.M. 36-061 ELEV. 233.373	N.W. Cor. Sargent Ave. & Garfield St. N., Tbt. in S. Conc. foundation of Sargent Ave. Mennonite Church, 0.5m W. & 1.7m below brick of S.E. Cor. of Bldg.
DESIGNED BY	RBO
CHECKED BY	CR
DRAWN BY	GEL
APPROVED BY	
HOR. SCALE:	1:250
VERTICAL:	1:50
ISSUED FOR TENDER	13/06/12
NO. REVISIONS	DATE BY



DESIGNED BY RBO CHECKED BY CR
DRAWN BY GEL APPROVED BY
HOR. SCALE: 1:250
VERTICAL: 1:50

RELEASED FOR CONSTRUCTION: 13/06/12

CONSULTANT DRAWING NO.	13-0107-007-C11
DATE	13/06/12

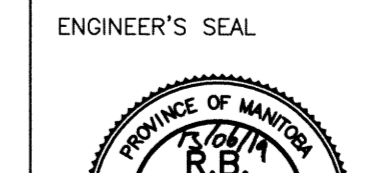

THE CITY OF WINNIPEG
PUBLIC WORKS DEPARTMENT
TRANSPORTATION ENGINEERING DIVISION

PROJECT TITLE
2013 ALLEY RENEWAL PROGRAM
CONTRACT 1
DOMINION ST/GARFIELD ST
ELLICE AVE TO SARGENT AVE
STA 3+62.5 TO SARGENT AVE

SHEET 11 OF 16
COMPUTER FILE NAME
13-0107-007_CALL
CITY DRAWING NUMBER
0011

P:\Projects\2013\13-0107-007\DocControl\Tobias\dwg\13-0107-007-C11-Rev 0.dwg - Tab: 11 Plotted By: Glennen 06/19/2013 [Wed 7:16am] PLOT: 1:1 A-1