

**ORIENTATION**

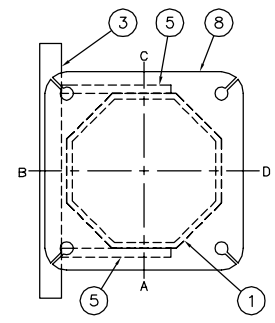

**PLAN-TOP VIEW**

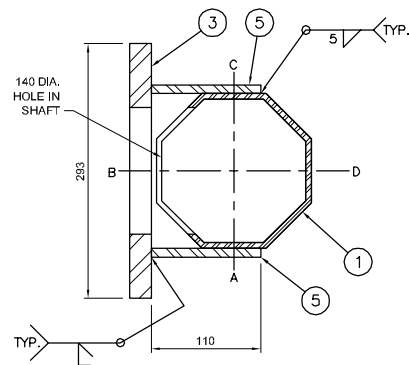

**SECTION 2**

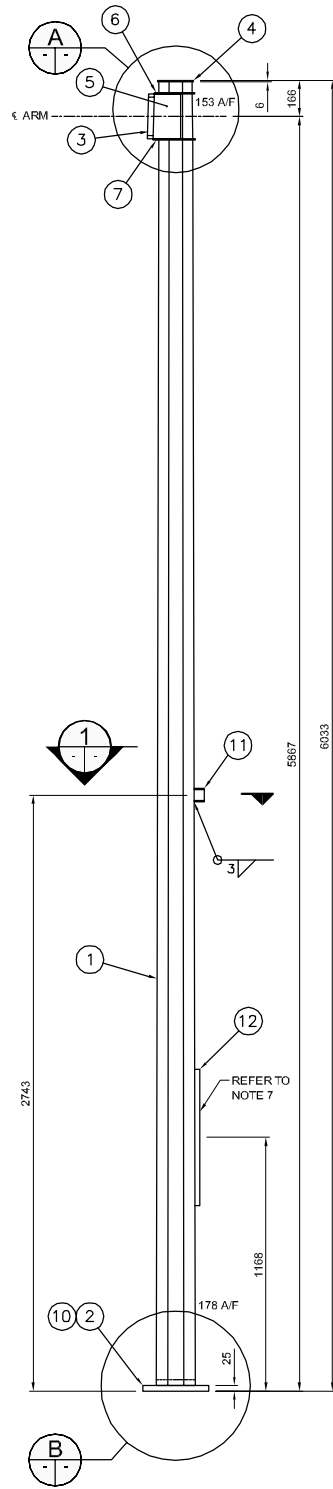

**SHAFT ELEVATION**

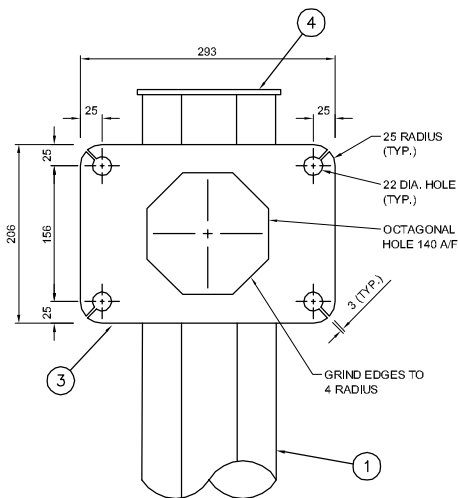

**FRONT VIEW**

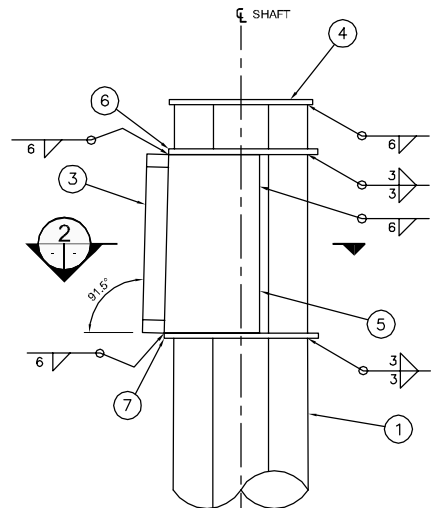

**SIDE VIEW**

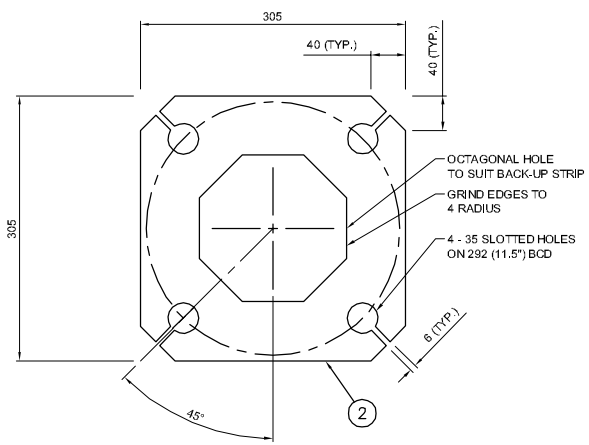

**PLAN**

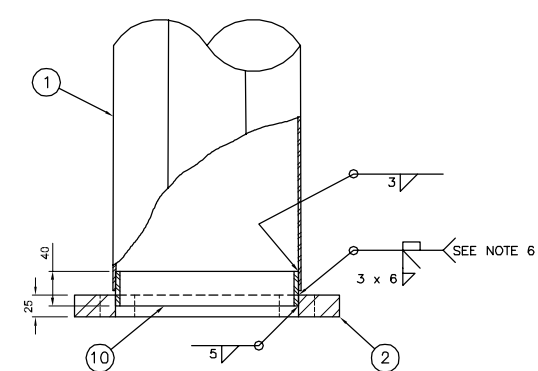

**ELEVATION**

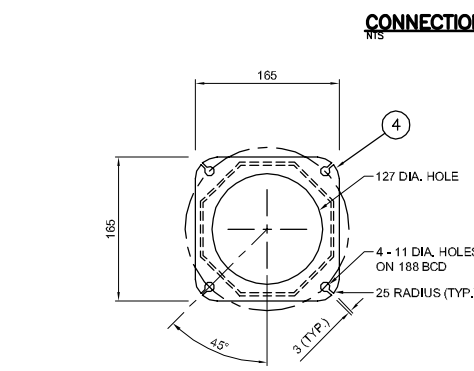

**TOP PLATE DETAIL**

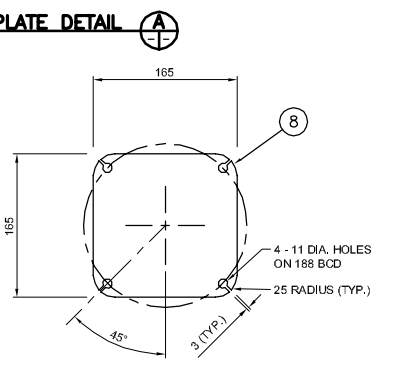

**CAP PLATE DETAIL**

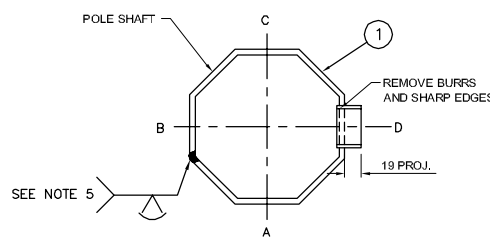

**SECTION 1**

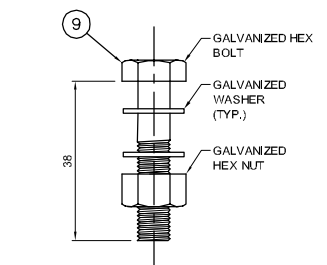

**CAP PLATE BOLT DETAIL**

BILL OF MATERIALS						
MK. NO.	QTY. REQ'D.	DESCRIPTION	SIZE	MATERIAL	REMARKS	LINE NO.
		<b>LIGHT DUTY SHAFT - L</b>				1
1	1	OCTAGONAL SECTION SHAFT	178 A/F - 153 A/F x 3.083	CSA G40.21 350W		2
2	1	BASE PLATE	25 x 305 x 305	CSA G40.21 300W		3
3	1	ARM FLANGE PLATE	25 x 206 x 293	CSA G40.21 300W		4
4	1	TOP PLATE	6 x 165 x 165	CSA G40.21 300W	SEE DETAIL C	5
5	2	SIDE PLATES	6 x 110 x 206	CSA G40.21 300W		6
6	1	TOP GUSSET PLATE	6 x 177 x 177	CSA G40.21 300W		7
7	1	BOTTOM GUSSET PLATE	6 x 177 x 182	CSA G40.21 300W		8
8	1	CAP PLATE	6 x 165 x 165	CSA G40.21 300W	SEE DETAIL D	9
9	4	CAP PLATE BOLT	10 (3/8") DIA. x 38	SAE GR. 5	SEE DETAIL E	10
10	1	BACK-UP STRIP PLATE	4.554 x 40	CSA G40.21 350W		11
11	1	PIPE PENETRATION (1 1/2") C/W PLUG	48 O.D. X 25	ASTM A53 GR. B SCH. 40	REMOVE BURRS AND SHARP EDGES	12
						13
12	1	ACCESS PANEL			SEE NOTE 7	14
						15
13	1	BREAKAWAY BASE ASSEMBLY			SUPPLIED BY OTHERS	16

APPROXIMATE TOTAL MASS = 106 kg

**NOTES:**

- ALL MATERIALS, EXCEPT STAINLESS STEEL ITEMS, SHALL BE HOT DIP GALVANIZED IN ACCORDANCE WITH ASTM A123-09 (PLUS LATEST REVISIONS) WITH NET RETENTION OF 610 g/m<sup>2</sup>.
- PROVIDE RAISED IDENTIFICATION NUMBER WITH WELDING ELECTRODE AS PER SPECIFICATION, STRUCTURE TYPE CODE = L.
- SHIP WITH CAP PLATE C/W NUTS AND WASHERS INSTALLED.
- GRIND ALL SHARP POINTS AND EDGES.
- LONGITUDINAL SEAM WELD SHALL HAVE 60% MINIMUM PENETRATION EXCEPT WITHIN 150 mm OF BASE PLATE AND 400 mm OF TOP PLATE SHALL BE COMPLETE PENETRATION.
- EXTERIOR WELD JOINING SHAFT TO BASE PLATE SHALL BE AN UNEQUAL LEG COMPLETE PENETRATION WELD WITH THE LONG LEG OF THE WELD ALONG THE SHAFT, TERMINATING AT 30" FROM THE SHAFT'S SURFACE.
- PROVIDE ACCESS PANEL IN ACCORDANCE WITH SHEET 13.

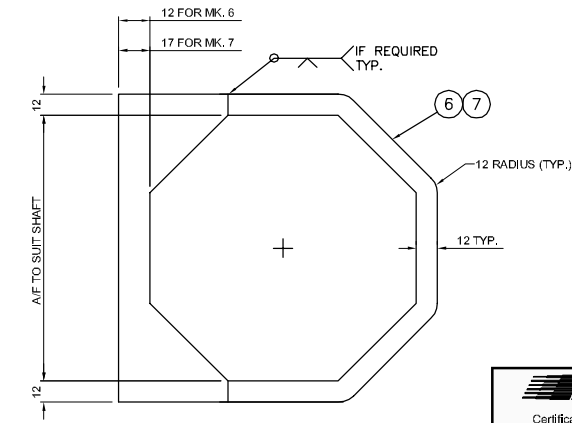

**GUSSET PLATE MK. 6 AND MK. 7**



**REDUCED DRAWING N.T.S.**

B.M. ELEV.	DESIGNED BY CDW				CITY DRAWING NUMBER N/A
	DRAWN BY JGW				SHEET 8 OF 13
	CHECKED BY SSR				CONSULTANT DRAWING NUMBER N/A
	APPROVED BY -				
	HOR. SCALE NTS				
	VERTICAL SCALE NTS				
1 ISSUED BY DILLON CONSULTING	1/14/13	CDW			
NO. REVISIONS	DATE	BY	DATE		

G:\CAD\125954\Contract\Current\LIGHT & MEDIUM SHAFT.dwg