

**ALLEY PAVEMENT PROFILE**

SCALE: 1:250 HOR  
1:10 VER

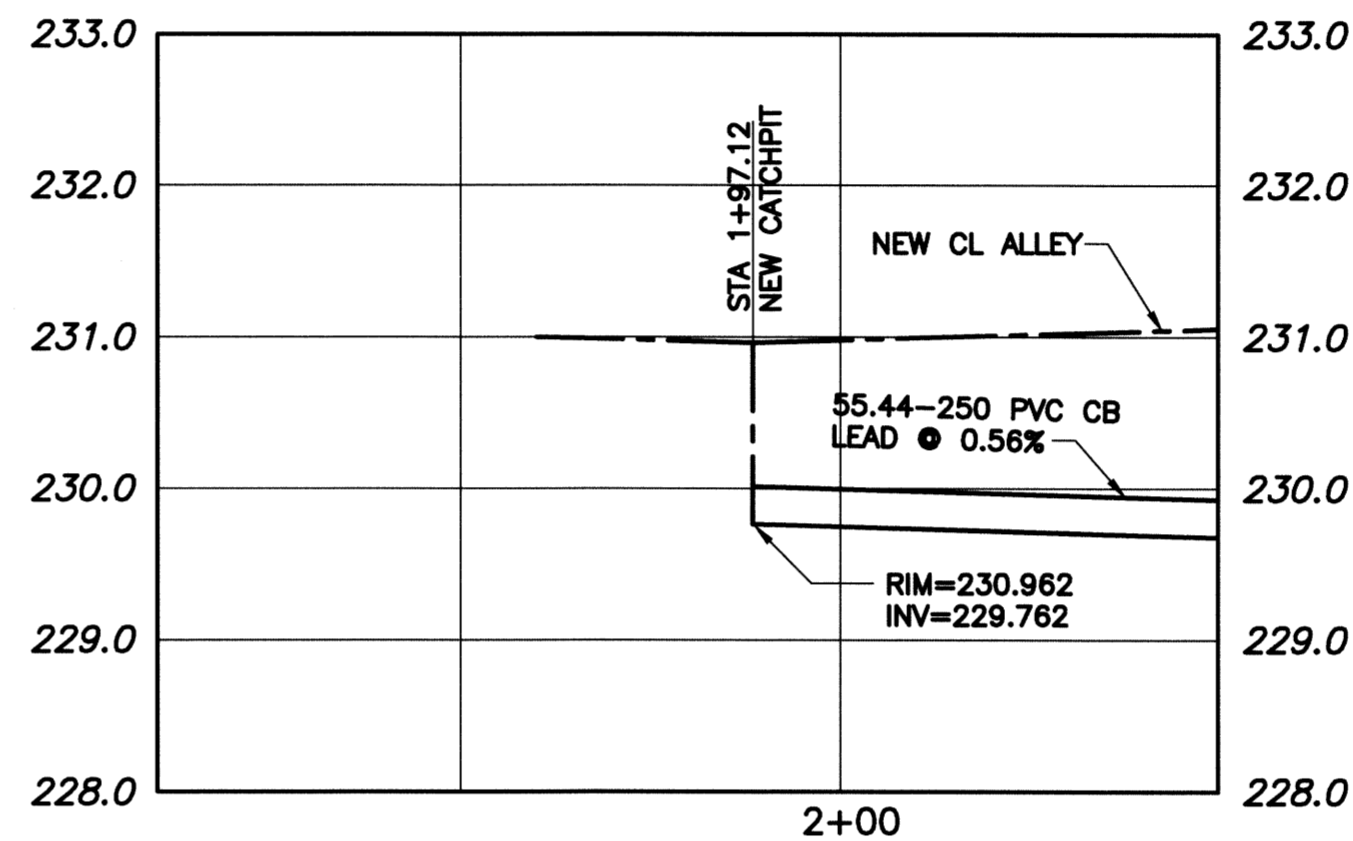

**ALLEY UNDERGROUND PROFILE**

SCALE: 1:250 HOR  
1:50 VER

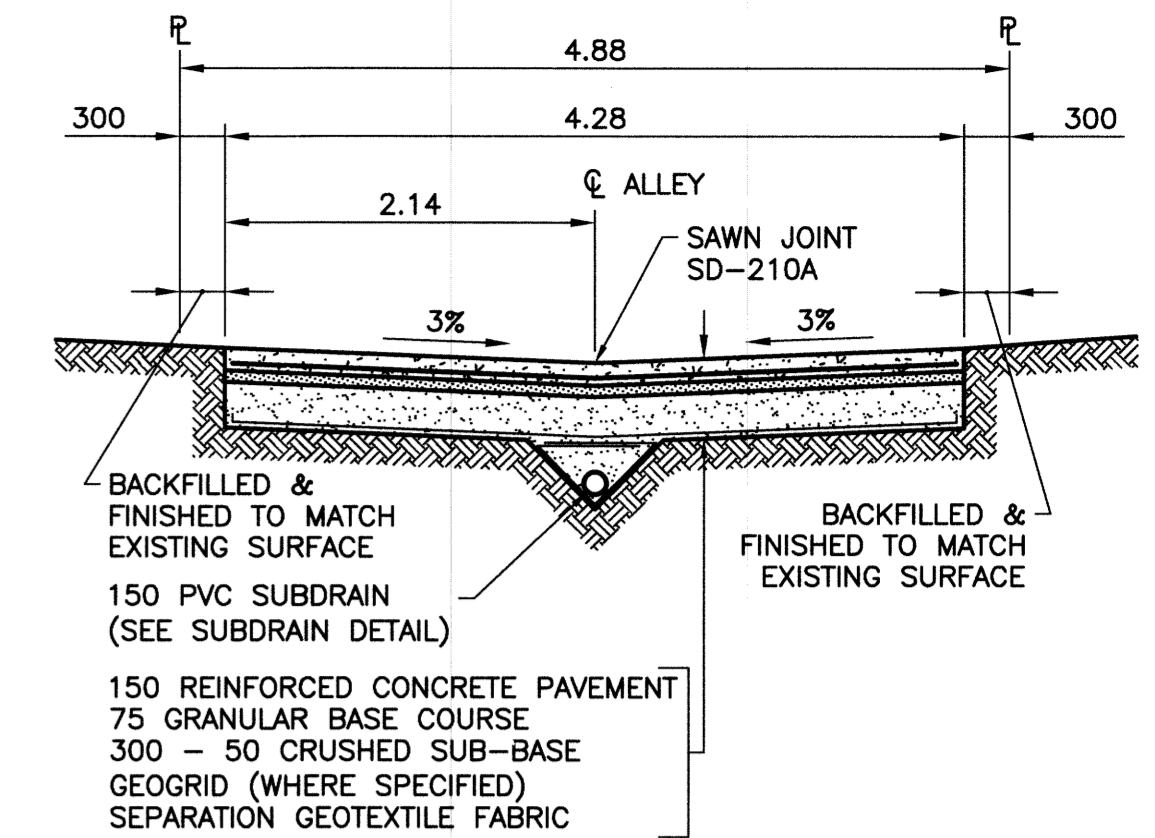

**TYPICAL CROSS SECTION**

SCALE: 1:50

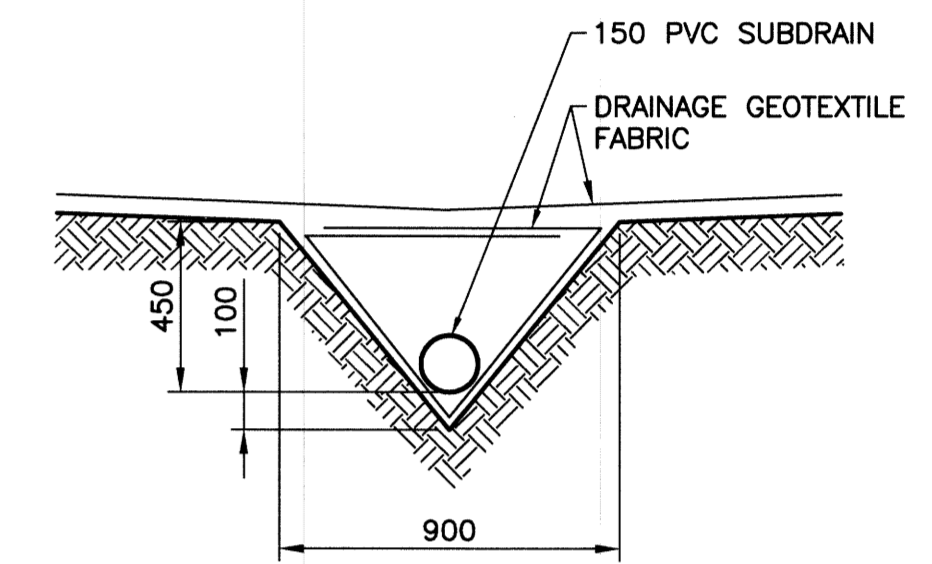

**SUBDRAIN DETAIL**

SCALE: 1:20

**NOTES:**

1. STATION CHAINAGE IS BASED ON CENTERLINE OF ALLEY RIGHT OF WAY.
2. ADJUST MH AND CB RIMS TO NEW GRADES.
3. PLUG SUBDRAINS AT TERMINAL ENDS.
4. REGRADE EXISTING PRIVATE SIDEWALKS AS REQUIRED.
5. INSTALLATION OF LIP CURBS AND THEIR EXTENTS TO BE DETERMINED BY THE CONTRACT ADMINISTRATOR.
6. LIGHT STANDARDS, HYDRO POLES AND ANCHORS MAY REQUIRE TEMPORARY SUPPORT/REMOVAL OR REPLACEMENT AT THE CONTRACTOR'S EXPENSE.
7. ISOLATE ALL POLES, BASES AND PILES WITHIN ALLEY RIGHT OF WAY (SD-228C)
8. AVOID DAMAGE TO EXISTING TREES WITHIN THE LIMITS OF CONSTRUCTION.

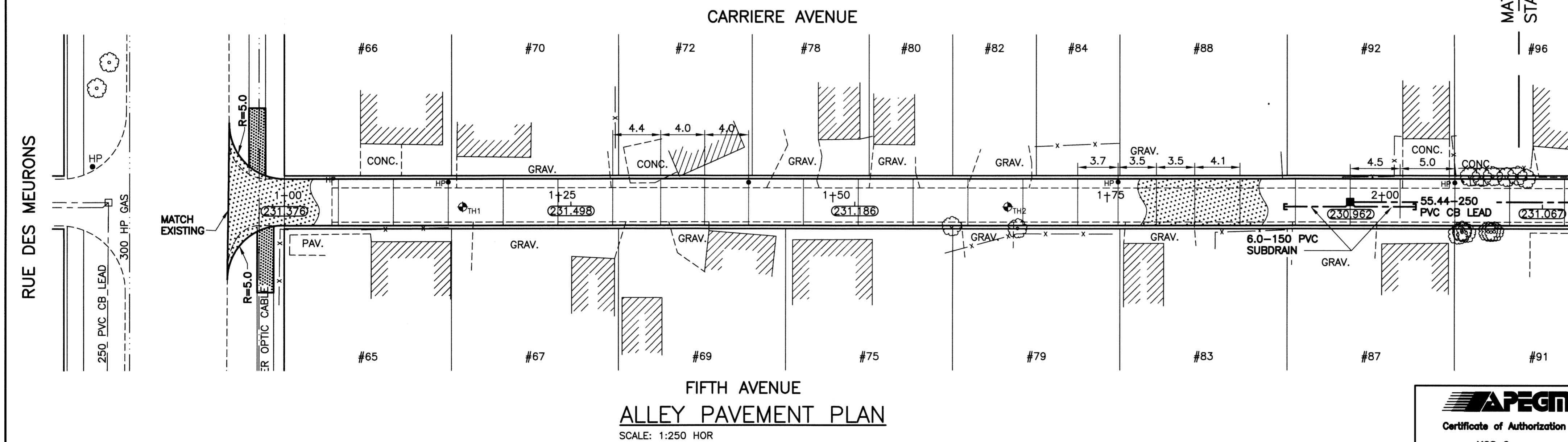

**ALLEY PAVEMENT PLAN**

SCALE: 1:250 HOR



**WARNING**  
NOTIFY THE GAS COMPANY OF THE PROPOSED LOCATION OF EXCAVATION. TAKE PRECAUTION TO AVOID DAMAGE TO GAS COMPANY INSTALLATIONS. SEE PROVINCIAL REGULATION 210/72 FOR DETAILS.

**METRIC**  
WHOLE NUMBERS INDICATE MILLIMETRES  
DECIMALIZED NUMBERS INDICATE METRES

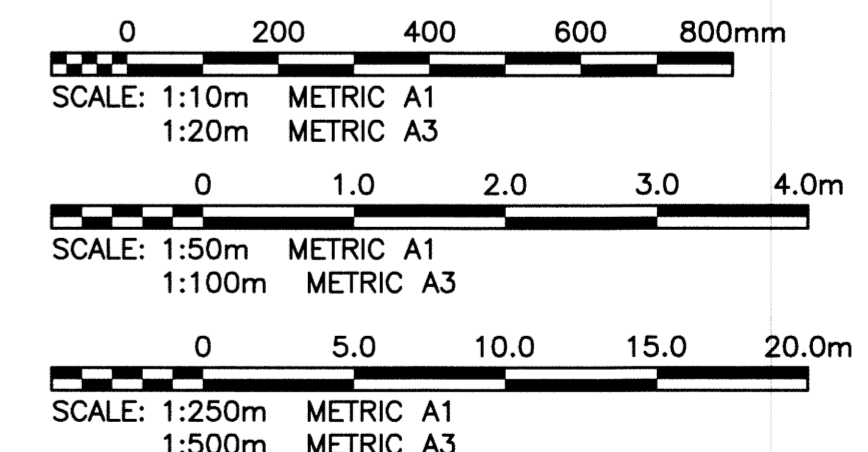

**PROPERTY LIMITS DELINEATION**  
DELINEATION OF PROPERTY LIMITS AS SHOWN ON THIS DWG DOES NOT REPRESENT A "LEGAL SURVEY". KGS GROUP MAKES NO REPRESENTATION OR WARRANTY AS TO THE ACCURACY OF PROPERTY LIMITS DELINEATED ON THIS DWG, NOR ON THE DIMENSIONAL ACCURACY OF DWG FEATURES RELATIVE TO THOSE PROPERTY LIMITS.

**APEGM**  
Certificate of Authorization  
**KGS Group**  
No. 245

300 LDS	LAND DRAINAGE SEWER	300 LDS		TEST HOLE	
250 WWS	WASTE WATER SEWER	250 WWS		GUY WIRE	
	GAS			LIGHT STANDARD	
	HYDRO			BACK OF CURB	
	M.T.S.			CONCRETE	
150 WM	WATERMAIN	150 WM		ASPHALT	
	HYDRANT			SIDEWALK	
	VALVE			PROPERTY LINE	
	MANHOLE			SURVEY BAR	
	CATCH BASIN			GEODETIC BENCHMARK	
	CURB INLET			ELEVATION	231.334
	POLES				
EXISTING	LEGEND-PLAN	PROPOSED	EXISTING	LEGEND-PLAN	PROPOSED

**LOCATION APPROVED UNDERGROUND STRUCTURES**  
SUPV. U/G STRUCTURES COMMITTEE DATE  
NOTE: LOCATION OF UNDERGROUND STRUCTURES AS SHOWN ARE BASED ON THE BEST INFORMATION AVAILABLE BUT NO GUARANTEE IS GIVEN THAT ALL EXISTING UTILITIES ARE SHOWN OR THAT THE GIVEN LOCATIONS ARE EXACT. CONFIRMATION OF EXISTENCE AND EXACT LOCATION OF ALL SERVICES MUST BE OBTAINED FROM THE INDIVIDUAL UTILITIES BEFORE PROCEEDING WITH CONSTRUCTION.

B.M. - 8 ELEV. - 231.460	N.E. Cor. Carriere Ave. & Bristol Ave., T411, in S. Conc. foundation of duplex No. 56 & No. 58 Bristol Ave., 3.5m E. & 0.2m below stucco of S.W. Cor. of 869.
DESIGNED BY AKW	CHECKED BY CR
DRAWN BY DMW	APPROVED BY CR
HOR. SCALE: 1:250 VERTICAL: 1:50	RELEASED FOR CONSTRUCTION:
0 ISSUED FOR TENDER 13/08/13	13/08/12
NO. REVISIONS	DATE BY

ENGINEER'S SEAL  
**M.C. ROWBOLAN**  
Member  
PROFESSIONAL ENGINEER  
AUGUST 13, 2013  
CONSULTANT DRAWING NO.  
13-0107-006\_C05

**THE CITY OF WINNIPEG**  
PUBLIC WORKS DEPARTMENT  
TRANSPORTATION ENGINEERING DIVISION  
PROJECT TITLE  
**2013 LOCAL IMPROVEMENT ALLEY PROGRAM**  
SHEET OF  
**05** OF **09**  
COMPUTER FILE NAME  
13-0107-006\_CALL  
CITY DRAWING NUMBER  
**0005**

P:\Projects\2013\13-0107-006\DocControl\ToBeIssued\DWG\13-0107-006\_C05\_Rev 0.dwg - Tab: 05 Plotted By: GLoewen 08/13/2013 [True 4:00pm] PLOT 1:1 A-1