

ALLEY PAVEMENT PROFILE
SCALE: 1:250 HOR
1:10 VER

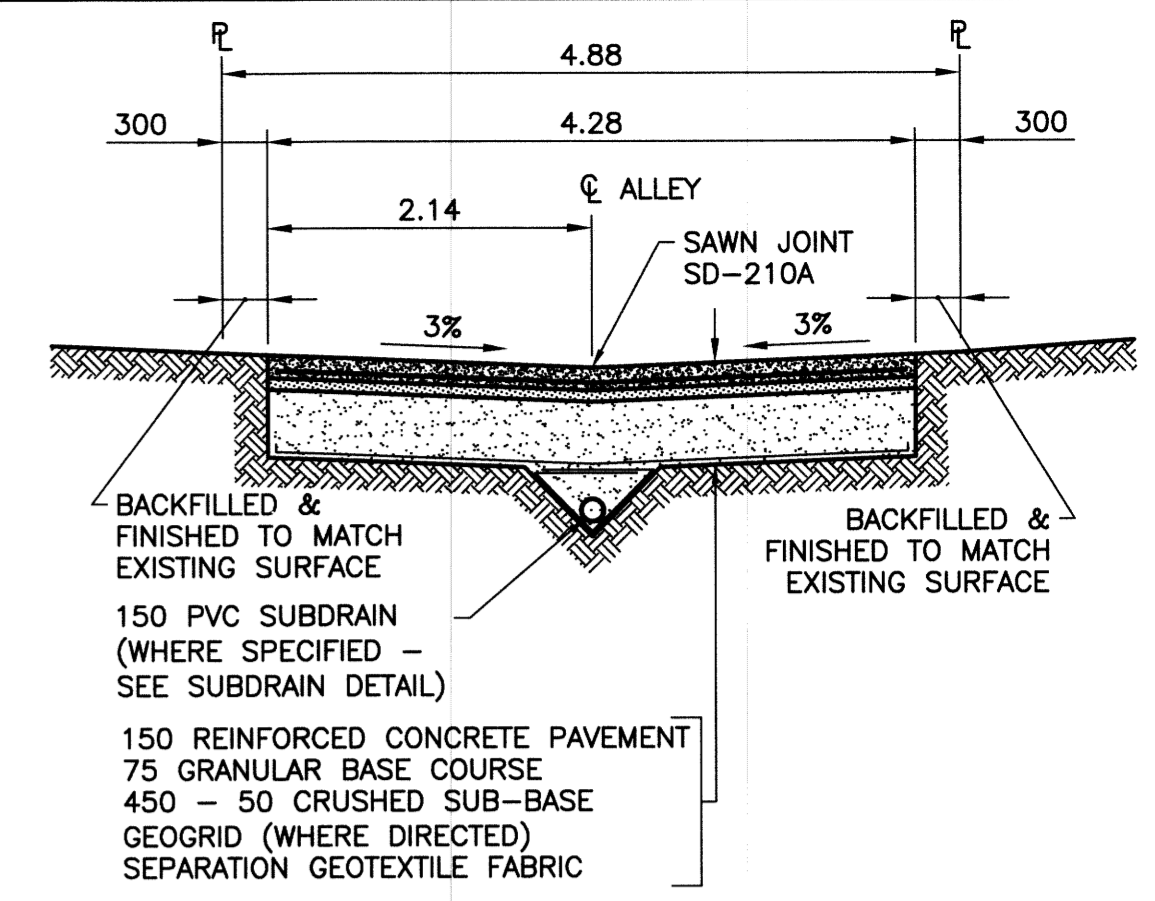

TYPICAL CROSS SECTION
SCALE: 1:50

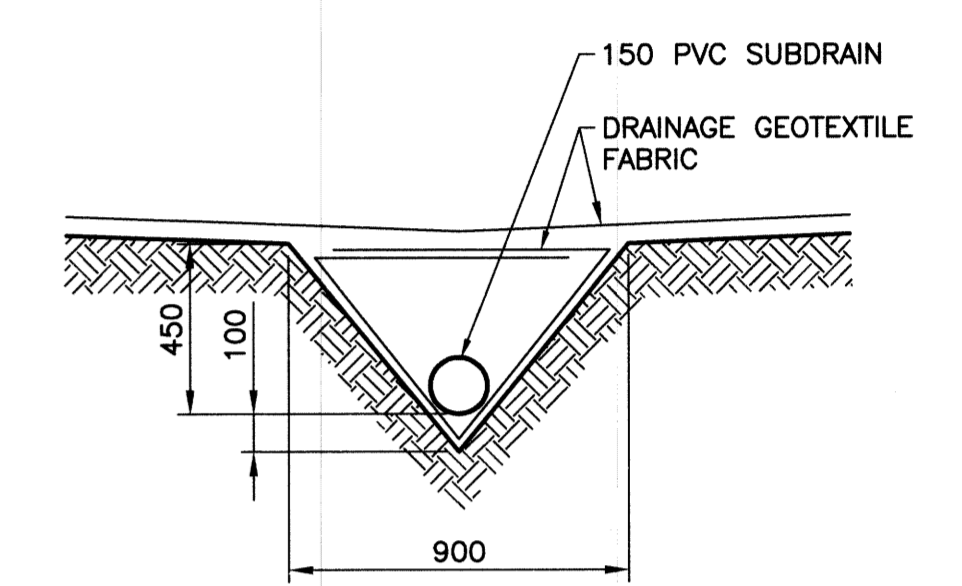

SUBDRAIN DETAIL
SCALE: 1:20

- NOTES:**
- STATION CHAINAGE IS BASED ON CENTERLINE OF ALLEY RIGHT OF WAY.
 - ADJUST MH AND CB RIMS TO NEW GRADES.
 - PLUG SUBDRAINS AT TERMINAL ENDS.
 - REGRADE EXISTING PRIVATE SIDEWALKS AS REQUIRED.
 - INSTALLATION OF LIP CURBS AND THEIR EXTENTS TO BE DETERMINED BY THE CONTRACT ADMINISTRATOR.
 - LIGHT STANDARDS, HYDRO POLES AND ANCHORS MAY REQUIRE TEMPORARY SUPPORT/REMOVAL OR REPLACEMENT AT THE CONTRACTOR'S EXPENSE.
 - ISOLATE ALL POLES, BASES AND PILES WITHIN ALLEY RIGHT OF WAY (SD-22BC)
 - AVOID DAMAGE TO EXISTING TREES WITHIN THE LIMITS OF CONSTRUCTION.

WARNING
NOTIFY THE GAS COMPANY OF THE PROPOSED LOCATION OF EXCAVATION. TAKE PRECAUTION TO AVOID DAMAGE TO GAS COMPANY INSTALLATIONS. SEE PROVINCIAL REGULATION 210/72 FOR DETAILS.

METRIC
WHOLE NUMBERS INDICATE MILLIMETRES
DECIMALIZED NUMBERS INDICATE METRES

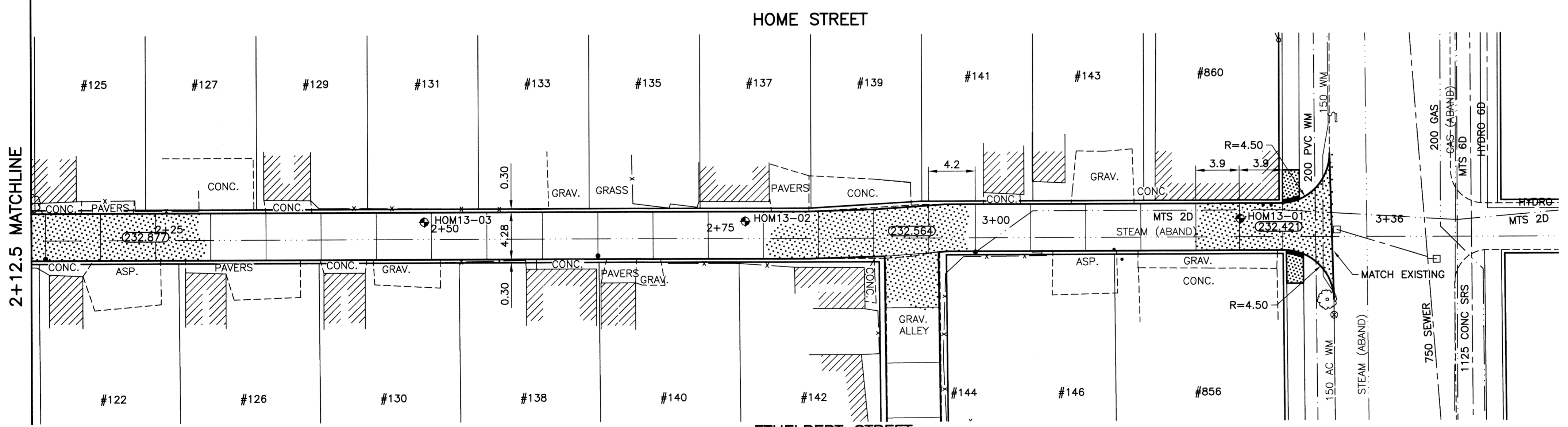
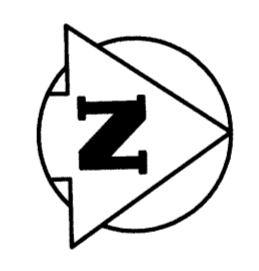

ALLEY PAVEMENT PLAN
SCALE: 1:250 HOR

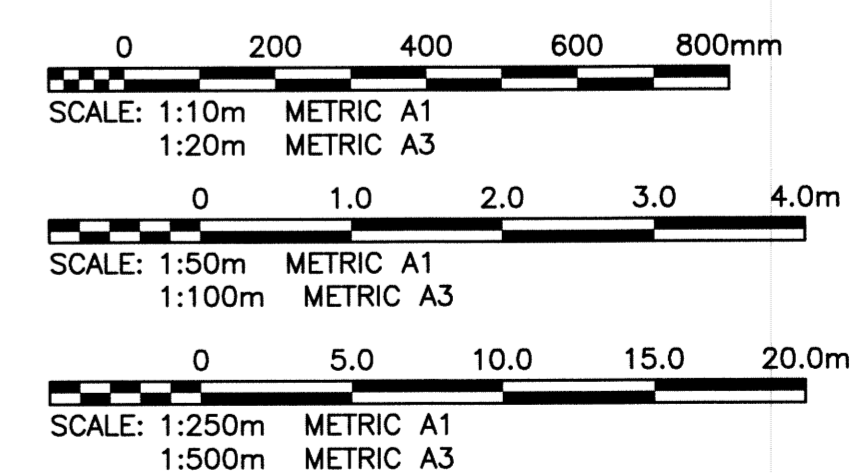

PROPERTY LIMITS DELINEATION
DELINEATION OF PROPERTY LIMITS AS SHOWN ON THIS DWG DOES NOT REPRESENT A "LEGAL SURVEY". KGS GROUP MAKES NO REPRESENTATION OR WARRANTY AS TO THE ACCURACY OF PROPERTY LIMITS DELINEATED ON THIS DWG, NOR ON THE DIMENSIONAL ACCURACY OF DWG FEATURES RELATIVE TO THOSE PROPERTY LIMITS.



EXISTING	LEGEND-PLAN	PROPOSED	EXISTING	LEGEND-PLAN	PROPOSED	EXISTING	LEGEND-PROFILE	PROPOSED
300 LDS	LAND DRAINAGE SEWER	300 LDS	TEST HOLE					
250 WWS	WASTE WATER SEWER	250 WWS	GUY WIRE					
	GAS		LIGHT STANDARD					
	HYDRO		BACK OF CURB					
	M.T.S.		CONCRETE					
150 WM	WATERMAIN	150 WM	ASPHALT					
	HYDRANT		SIDEWALK					
	VALVE		PROPERTY LINE					
	MANHOLE		SURVEY BAR					
	CATCH BASIN		GEODETIC BENCHMARK					
	CURB INLET		ELEVATION					
	POLES							

LOCATION APPROVED UNDERGROUND STRUCTURES

SUPV. U/G STRUCTURES COMMITTEE DATE

NOTE:
LOCATION OF UNDERGROUND STRUCTURES AS SHOWN ARE BASED ON THE BEST INFORMATION AVAILABLE BUT NO GUARANTEE IS GIVEN THAT THE GIVEN LOCATIONS ARE EXACT. CONFIRMATION OF EXISTENCE AND EXACT LOCATION OF ALL SERVICES MUST BE OBTAINED FROM THE INDIVIDUAL UTILITIES BEFORE PROCEEDING WITH CONSTRUCTION.

NO.	REVISIONS	DATE	BY
0	ISSUED FOR TENDER	13/08/22	GES

DESIGNED BY	CHECKED BY
GES	CR
DRAWN BY	APPROVED BY
GEL	APD
HOR. SCALE:	RELEASED FOR CONSTRUCTION:
1:250	
VERTICAL:	DATE
1:50	13/08/20

ENGINEER'S SEAL
M.C. ROWBOTHAM
Member 22679
AUG 22, 2013

THE CITY OF WINNIPEG
PUBLIC WORKS DEPARTMENT
TRANSPORTATION ENGINEERING DIVISION

PROJECT TITLE
2013 ALLEY RENEWAL PROGRAM CONTRACT 2
HOME ST/ETHELBERG ST
WOLSELEY AVE TO WESTMINSTER AVE
STA 2+12.5 TO WESTMINSTER AVE

SHEET OF
10 OF **15**

COMPUTER FILE NAME
13-0107-011_CALL

CITY DRAWING NUMBER
0010

CONSULTANT DRAWING NO.
13-0107-011_C10

P:\Projects\2013\13-0107-011\Doc\Contract\ToBeIssued\DWG\13-0107-011_C10-Rev 0.dwg - Tab: 10 Plotted By: Gloewen 08/22/2013 [Thu 3:32pm] PLOT 1:1 A-1