

OZONE COLUMNS PLAN
1:5

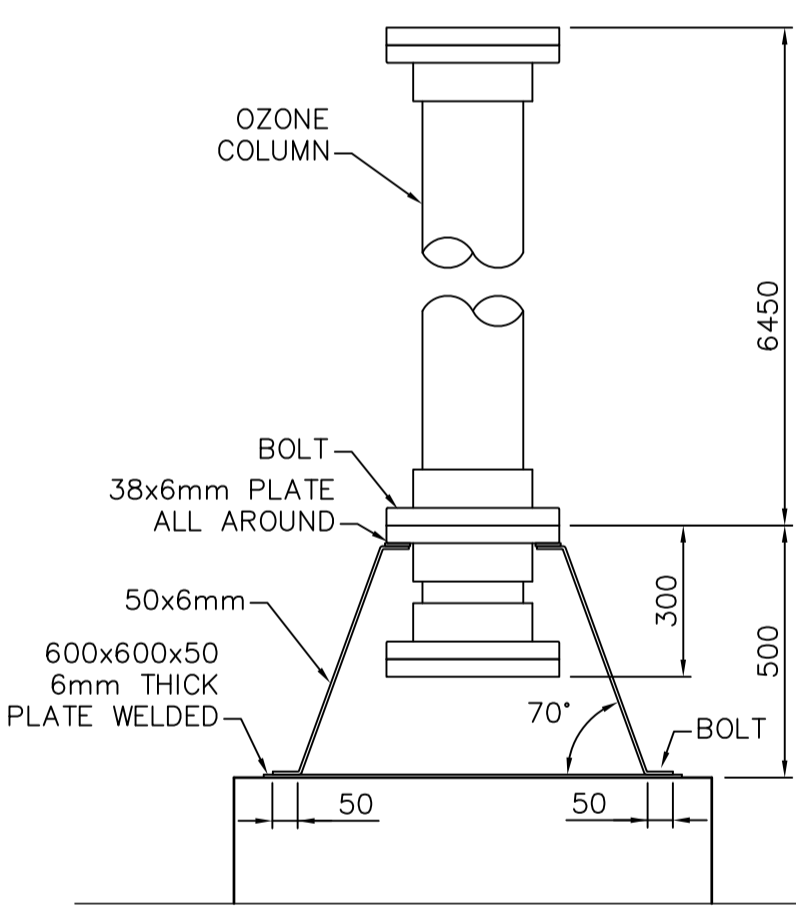

1
DETAIL
NTS

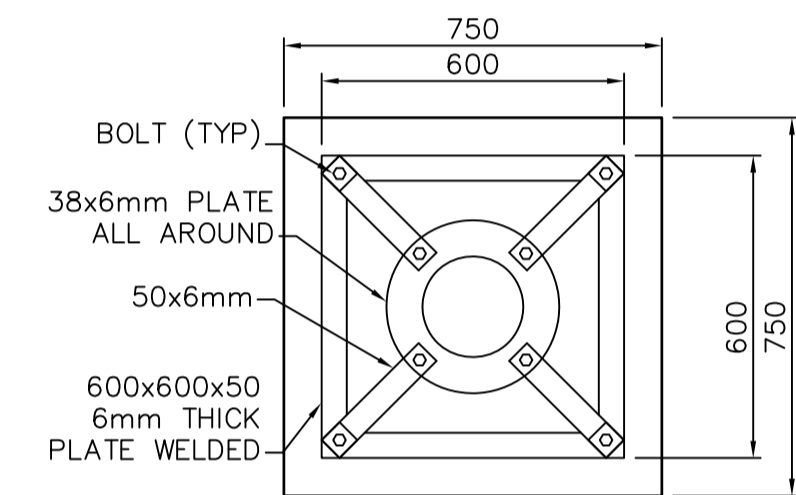
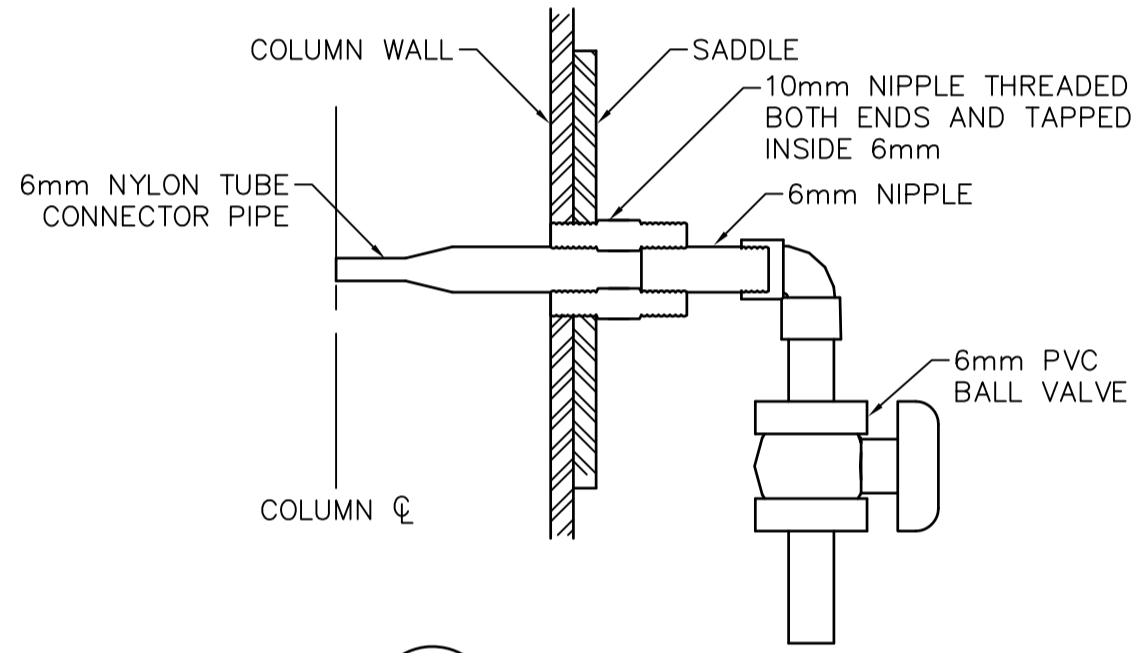

2
DETAIL
NTS

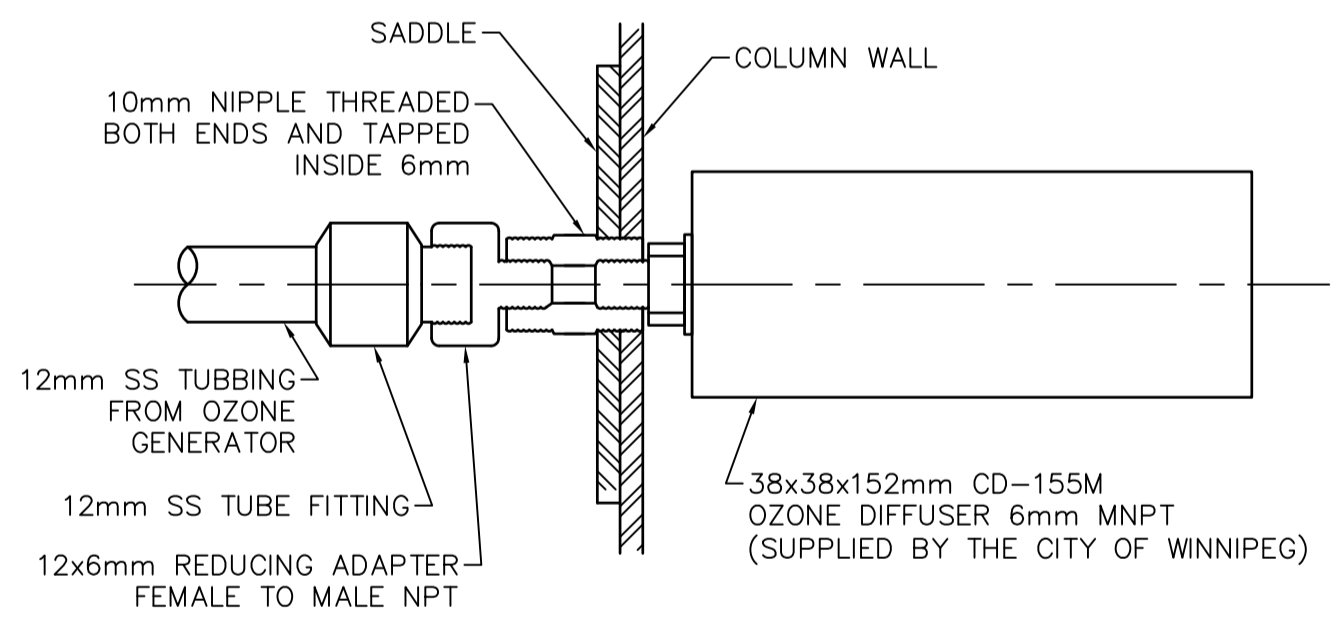

4
DETAIL
NTS

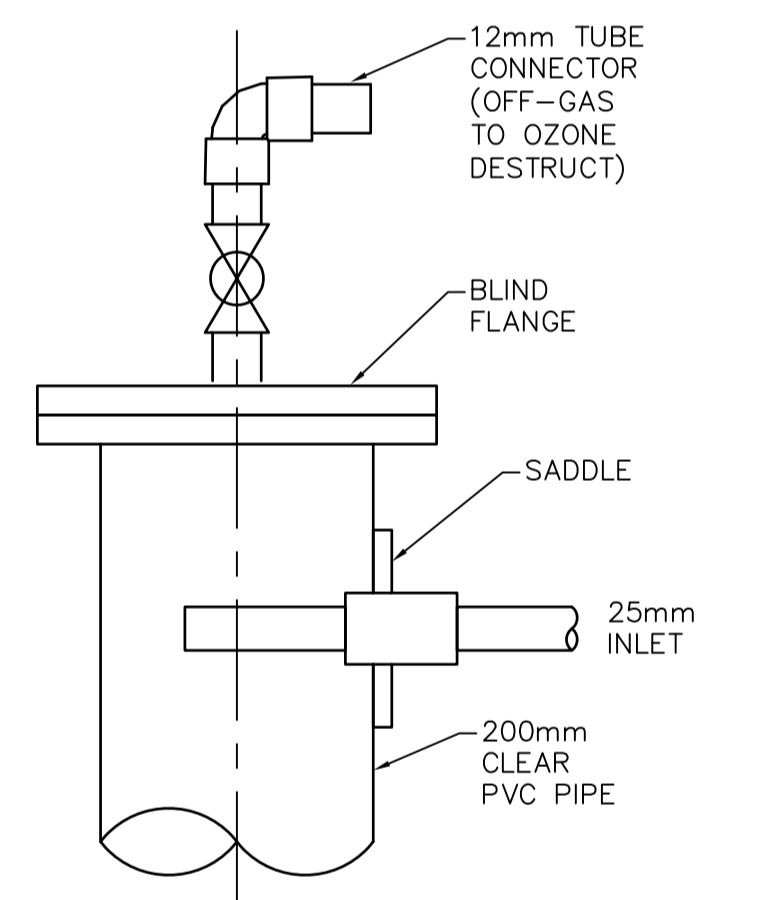

ELEVATION

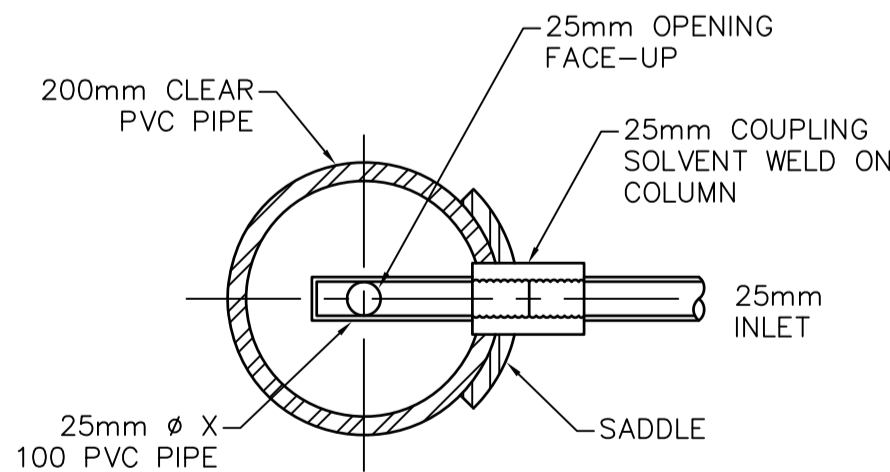

3
DETAIL
NTS

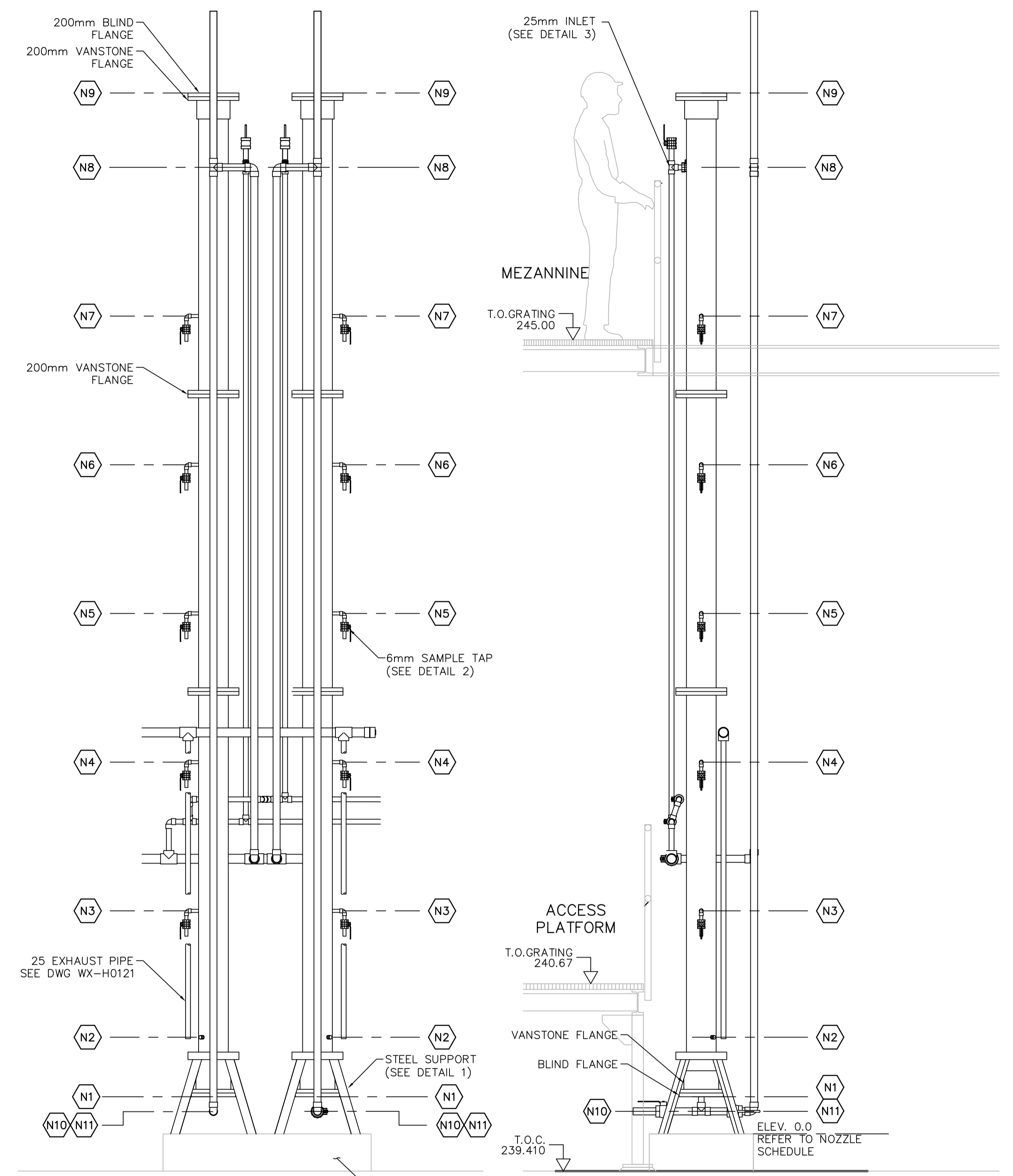

A
SECTION (FRONT)
1:20

B
SECTION
1:20

NOZZLE SCHEDULE			
TAG No.	SIZE/ SERVICE	DESCRIPTION	ELEV.
N1	38mm OUTLET	DRILL AND TAP FOR NIPPLE	200
N2	6mm DIFFUSER INLET	SEE DETAIL 4	650
N3	6mm SAMPLE TAP	SEE DETAIL 2	1500
N4	6mm SAMPLE TAP	SEE DETAIL 2	2500
N5	6mm SAMPLE TAP	SEE DETAIL 2	3500
N6	6mm SAMPLE TAP	SEE DETAIL 2	4500
N7	6mm SAMPLE TAP	SEE DETAIL 2	5500
N8	25mm INLET	SEE DETAIL 3	6500
N9	12mm VENT	DRILL AND TAP 12mm NPT	7000
N10	38mm DRAIN		150 APPROX.
N11	38mm OZONATED WATER		150 APPROX.

NOTES:
DIFFUSER: SEE DETAIL 4
COLUMNS: ø200mm x 6800mm HIGH, SCH. 40 CLEAR PVC COLUMNS STRAPPED TO SUPPORTING STEEL FOR LATERAL STABILITY.

2

B.M. ELEV.			
CONSTRUCTION COMPLETION DATE: YYYY MM DD			
DESIGNED BY	KG	CHECKED BY	BW
DRAWN BY	JBC	APPROVED BY	BW
2 ISSUED FOR ADDENDUM NO. 2	15/02/19	JBC	
1 ISSUED FOR BID OP. 1068-2014	15/01/23	JBC	
0 ISSUED FOR TENDER	14/06/13	JBC	
NO.	REVISIONS	DATE	BY

CH2MHILL

SCALE: HORIZONTAL 1:50 VERTICAL -

DATE 2014 06 13

PLOT DATE: 2015 02 19

ENGINEER'S SEAL
ORIGINAL SIGNED BY S.B. WILLIAMSON JAN 26, 2015
CONSULTANT DRAWING NUMBER WX-M0401

THE CITY OF WINNIPEG
WATER AND WASTE DEPARTMENT
ENGINEERING DIVISION

CITY OF WINNIPEG WATER TREATMENT RESEARCH AND PROCESS OPTIMIZATION FACILITY
PROCESS MECHANICAL
OZONE COLUMN DETAILS

SHEET X OF X
CITY DRAWING NUMBER
1-0601X-M0005-001-02