



Bridge Over the Falcon River Diversion and Associated Roadworks
Bid Opportunity No. 1141-2014

Bidders Conference – January 6, 2015

Falcon River Diversion and Associated Roadworks





Bridge Over the Falcon River Diversion and Associated Roadworks
Bid Opportunity No. 1141-2014

Bidders Conference – January 6, 2015

Agenda:

- Please Fill in the Sign-In Sheet
- Project Team
- Scope of Work
- Review of Tender Documents
- Questions





Bridge Over the Falcon River Diversion and Associated Roadworks
Bid Opportunity No. 1141-2014

Bidders Conference – January 6, 2015

City of Winnipeg – Water Services Division:

- Tim Shanks, P.Eng. – Manager of Water Services
- Chris Sauvé, P.Eng., PMP – Project Manager for Falcon River bridge project.





Bridge Over the Falcon River Diversion and Associated Roadworks
Bid Opportunity No. 1141-2014

Bidders Conference – January 6, 2015

Design Team

(Dillon/Trek):

- Graeme Loepky – Project Manager
- Kevin Willis – Bridge Design
- Graeme Loepky – Road Design
- Bruce Harding – Hydraulic Design
- Trek Geotechnical– Geotechnical Design

Contact Administration

(Dillon/Trek):

- Graeme Loepky – Project Manager
- Graeme Loepky – Contact Administrator
- Dillon – Resident Services
- Trek – Geotechnical Lead





Bridge Over the Falcon River Diversion and Associated Roadworks Bid Opportunity No. 1141-2014

Bidders Conference – January 6, 2015

Project Location:





Bridge Over the Falcon River Diversion and Associated Roadworks Bid Opportunity No. 1141-2014

Bidders Conference – January 6, 2015

Project Location:

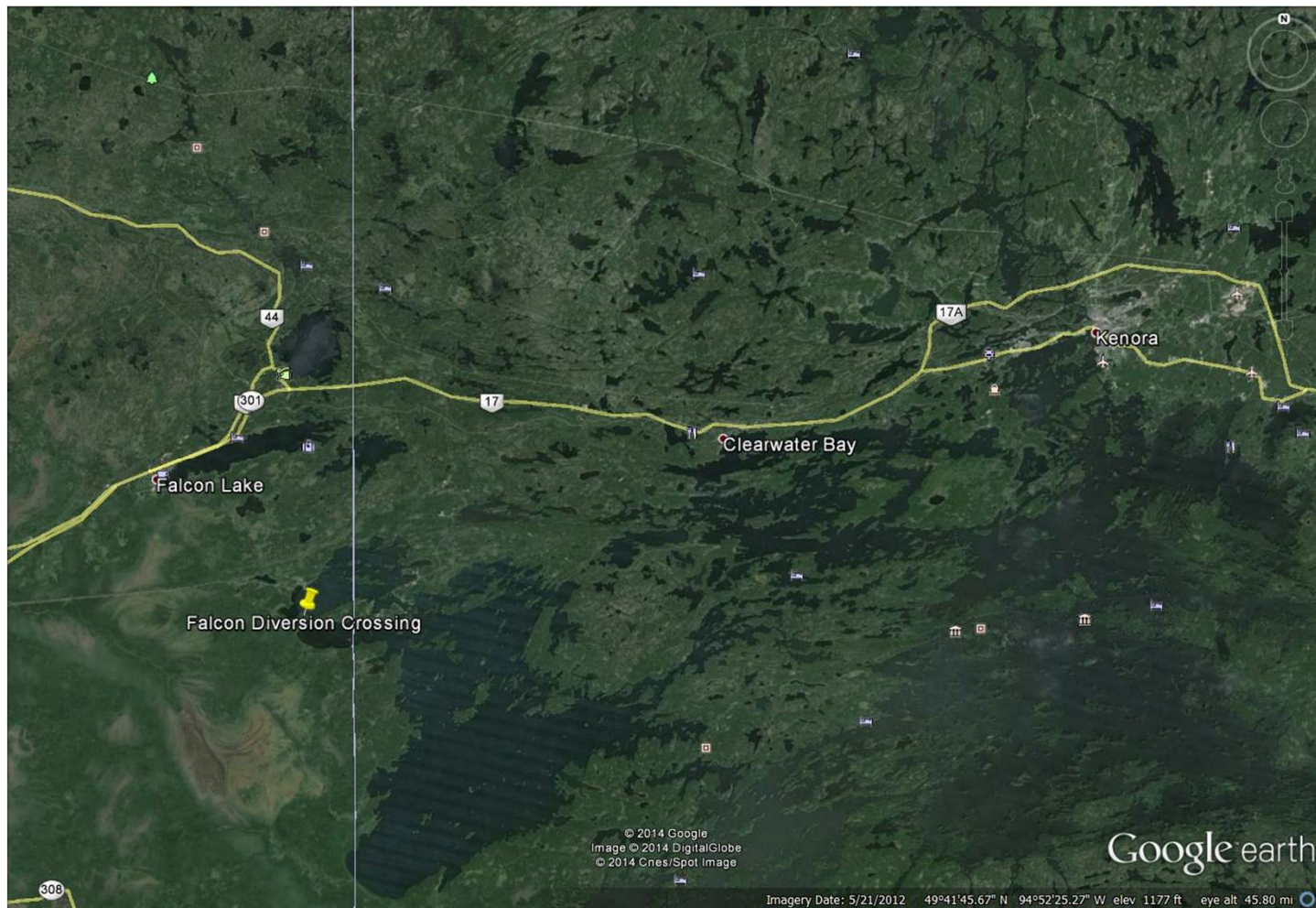



Bridge Over the Falcon River Diversion and Associated Roadworks Bid Opportunity No. 1141-2014

Bidders Conference – January 6, 2015

Project Location:

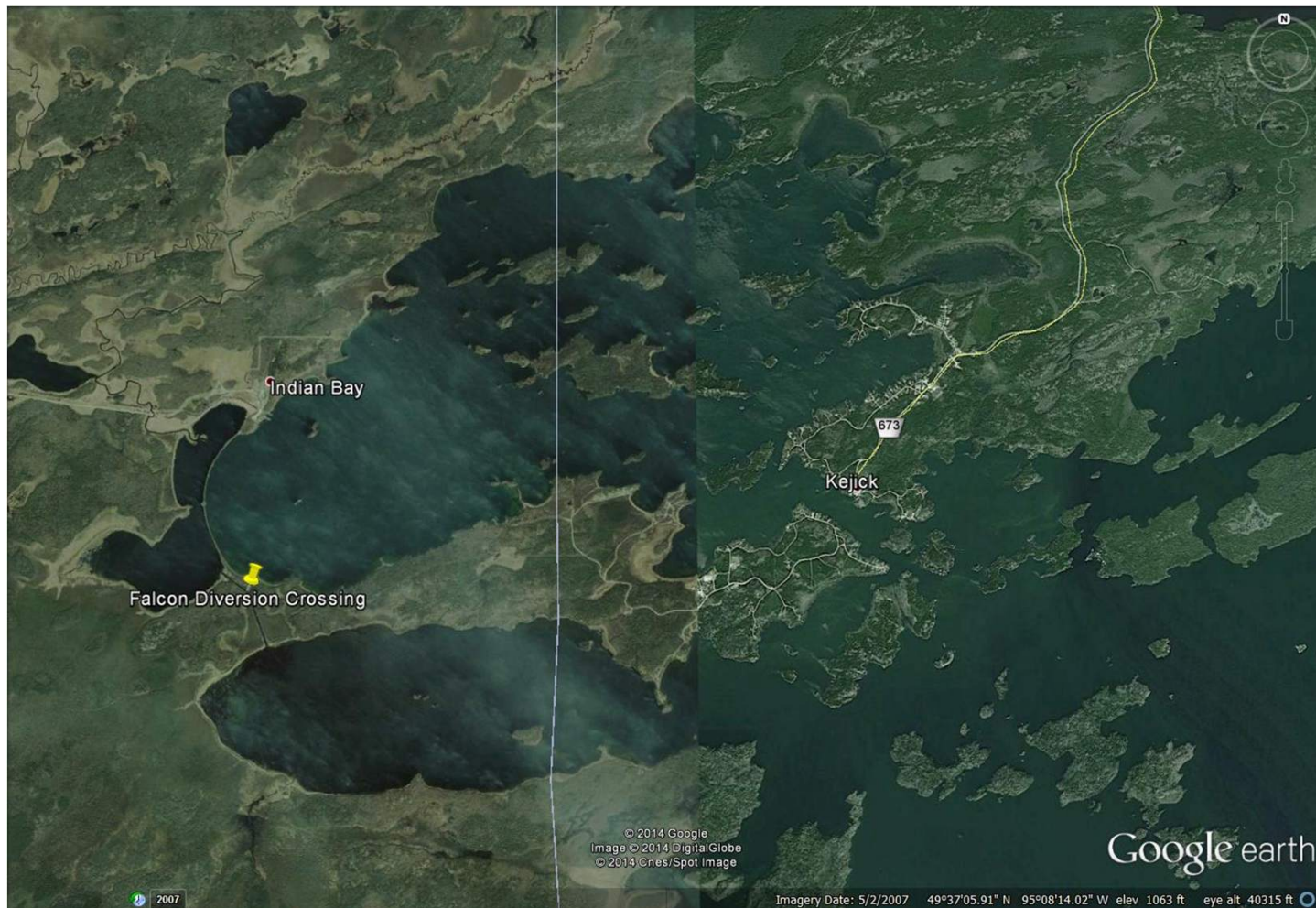



Bridge Over the Falcon River Diversion and Associated Roadworks Bid Opportunity No. 1141-2014

Bidders Conference – January 6, 2015

Project Location:

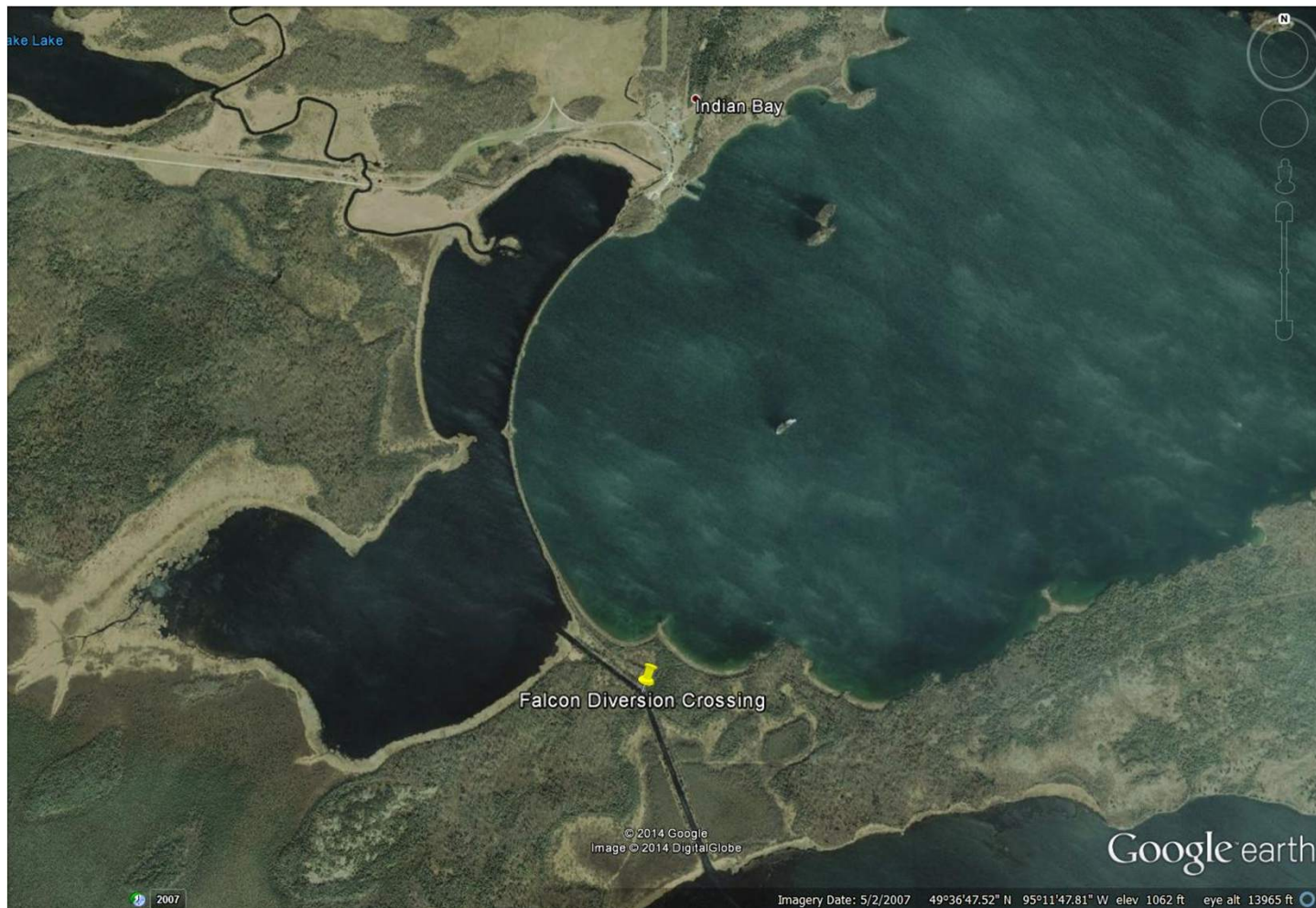



Bridge Over the Falcon River Diversion and Associated Roadworks

Bid Opportunity No. 1141-2014

Bidders Conference – January 6, 2015

Limits of Work:

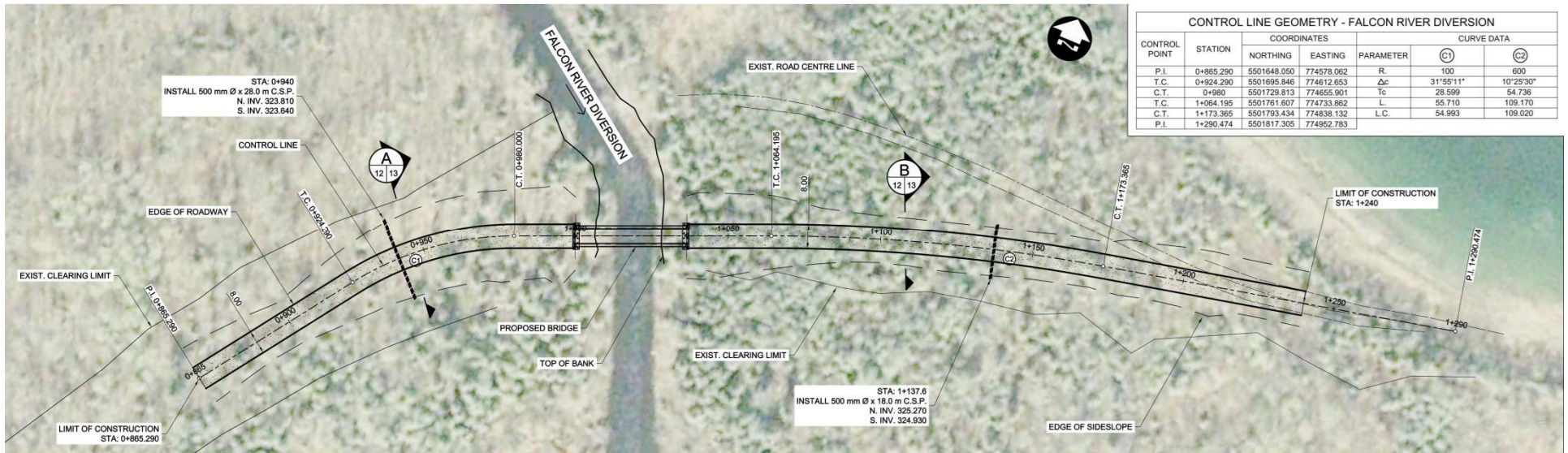



Bridge Over the Falcon River Diversion and Associated Roadworks Bid Opportunity No. 1141-2014

Bidders Conference – January 6, 2015

Scope of Work: Bridge Construction

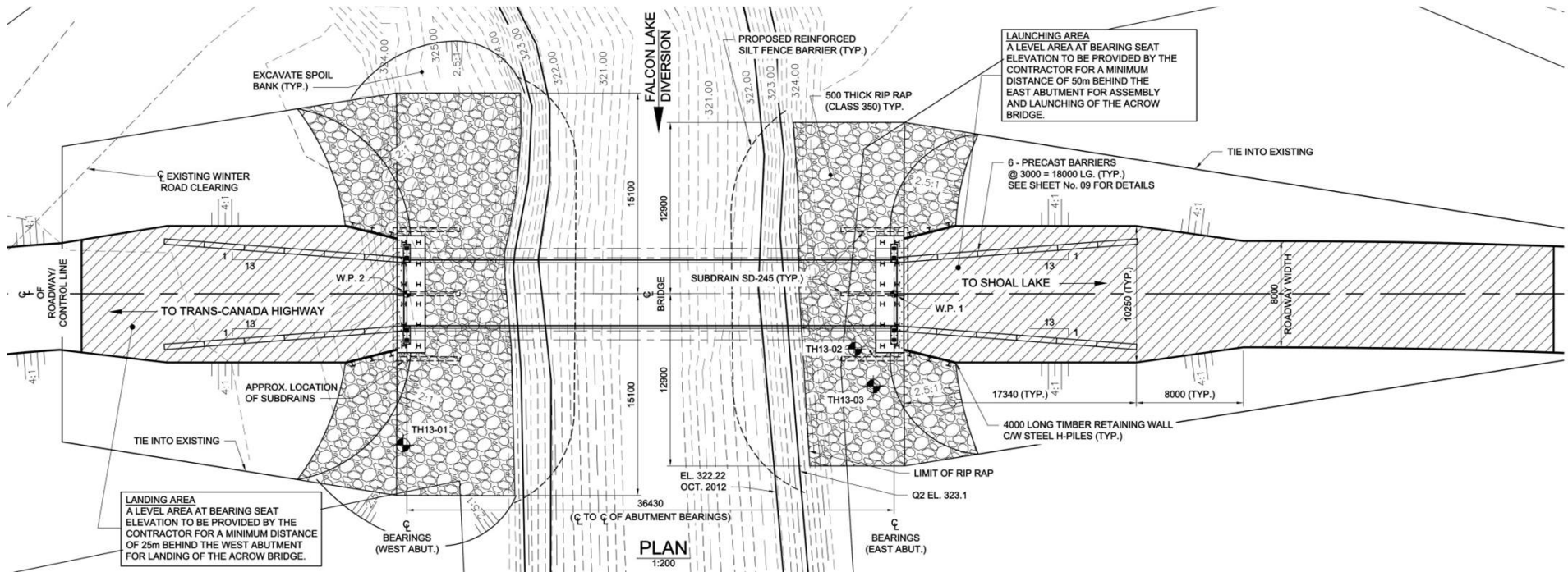



Bridge Over the Falcon River Diversion and Associated Roadworks Bid Opportunity No. 1141-2014

Bidders Conference – January 6, 2015

Scope of Work: Typical Road Cross Sections

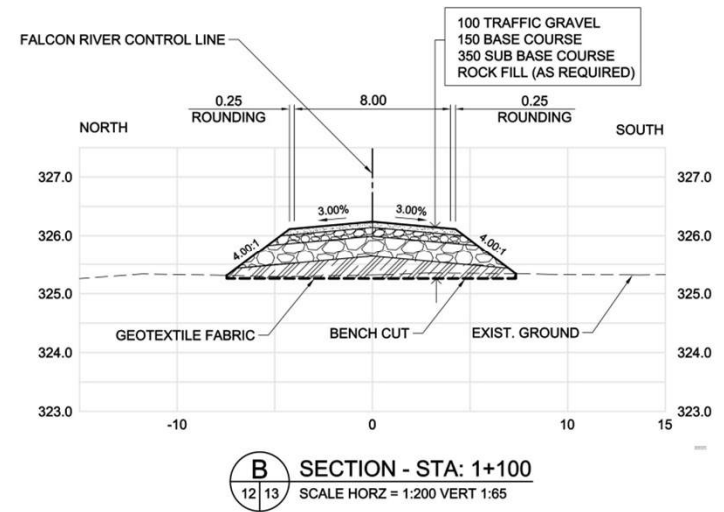
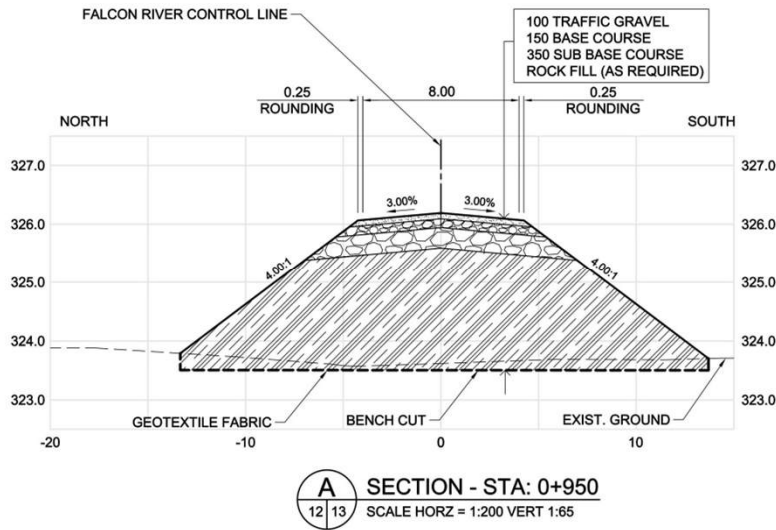



Bridge Over the Falcon River Diversion and Associated Roadworks
Bid Opportunity No. 1141-2014

Bidders Conference – January 6, 2015

Scope of Work:

- Construction of an Acrow panel bridge over the Falcon River Diversion
 - Supply and driving steel piles
 - Supply and placement of reinforcing steel
 - Construction of reinforced concrete abutments
 - Design, transportation, assembly and erection of Acrow panel bridge
 - Supply and installation of timber bridge deck, backwalls, and wingwalls





Bridge Over the Falcon River Diversion and Associated Roadworks
Bid Opportunity No. 1141-2014

Bidders Conference – January 6, 2015

Scope of Work:

- Construction of an Acrow panel bridge over the Falcon River Diversion (cont'd)
 - Supply and installation of guard rail
 - Supply and placement of backfilling at abutments
 - Supply and placement of rip-rap at abutments
 - Hauling and placing granular material to construct approach roadway embankments
 - Supply and installation of culverts
 - Removal of temporary works, working bridges and platforms
 - Erosion and sediment control and re-vegetation





Bridge Over the Falcon River Diversion and Associated Roadworks Bid Opportunity No. 1141-2014

Bidders Conference – January 6, 2015

Abutment Details:

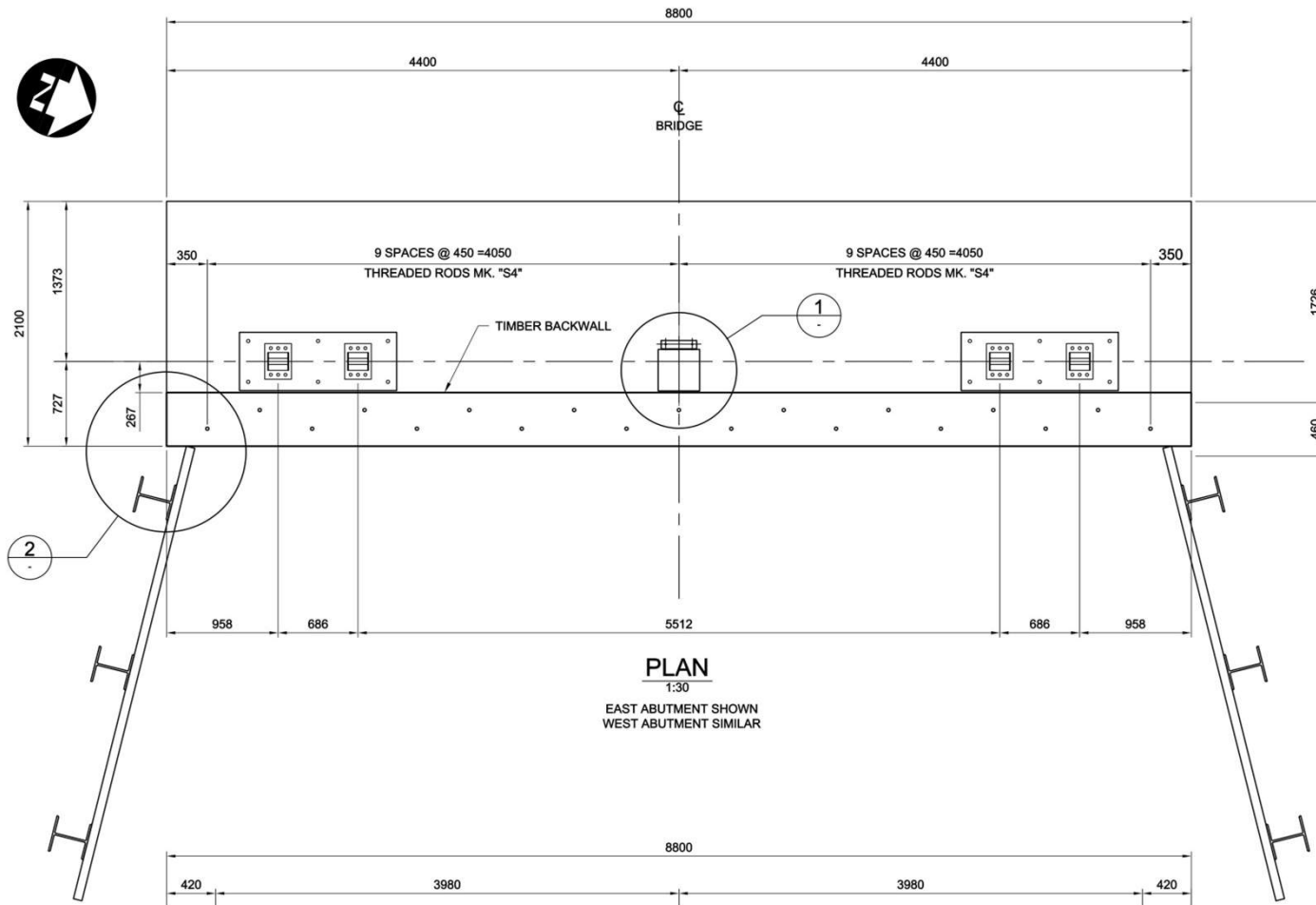



Bridge Over the Falcon River Diversion and Associated Roadworks Bid Opportunity No. 1141-2014

Bidders Conference – January 6, 2015

Abutment Details (cont'd):

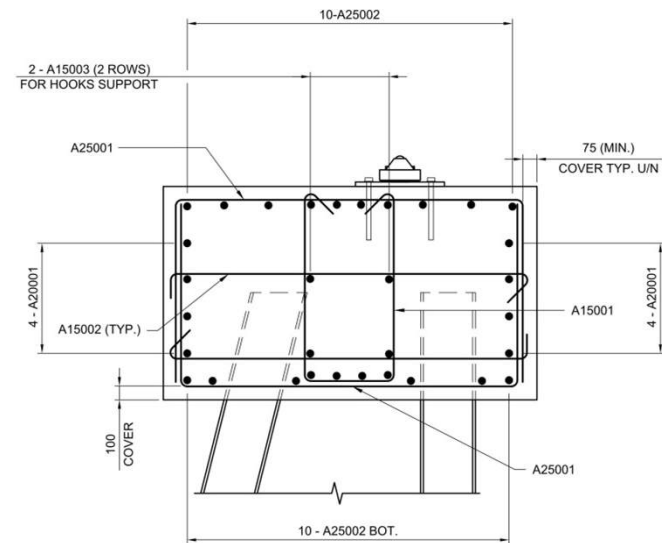
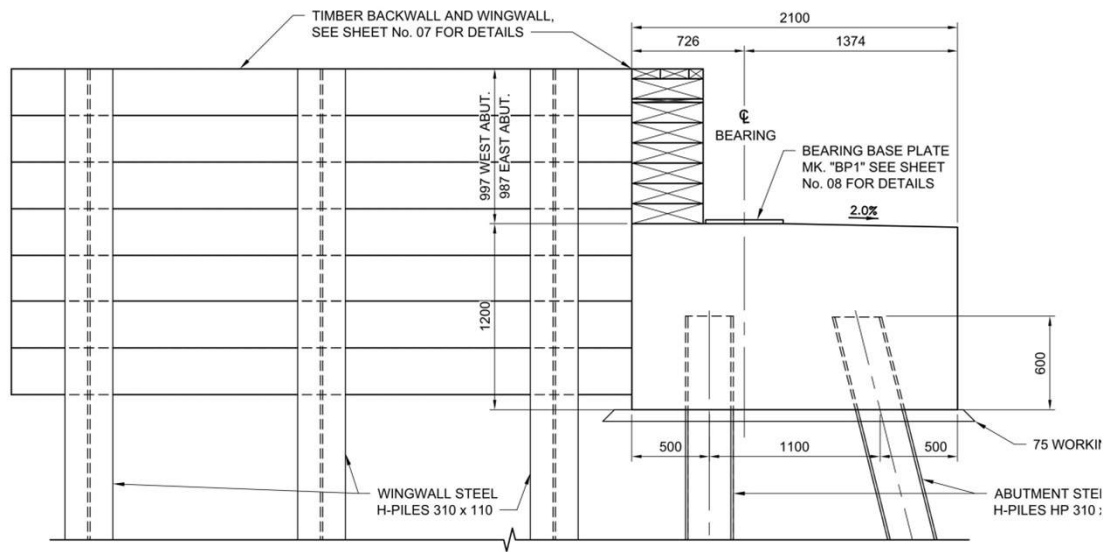



Bridge Over the Falcon River Diversion and Associated Roadworks Bid Opportunity No. 1141-2014

Bidders Conference – January 6, 2015

Abutment Backwall Detail:

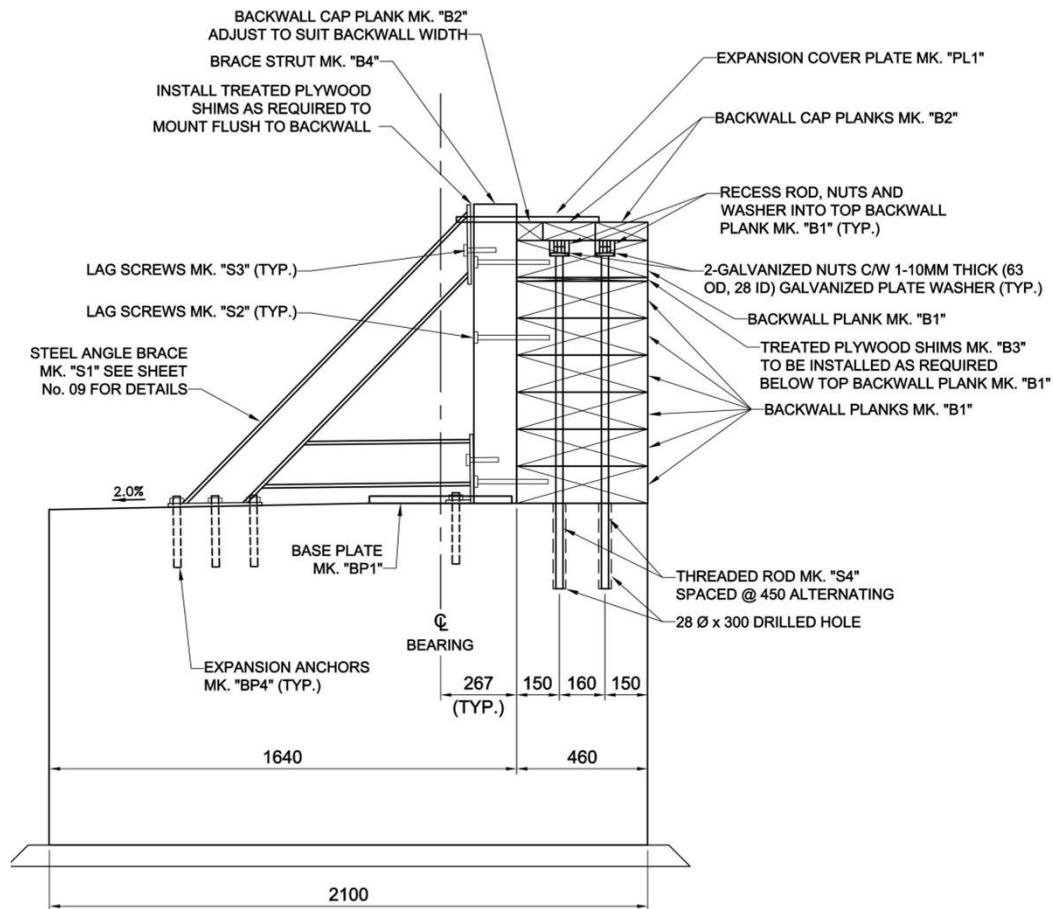



Bridge Over the Falcon River Diversion and Associated Roadworks Bid Opportunity No. 1141-2014

Bidders Conference – January 6, 2015

Timber Deck Details:

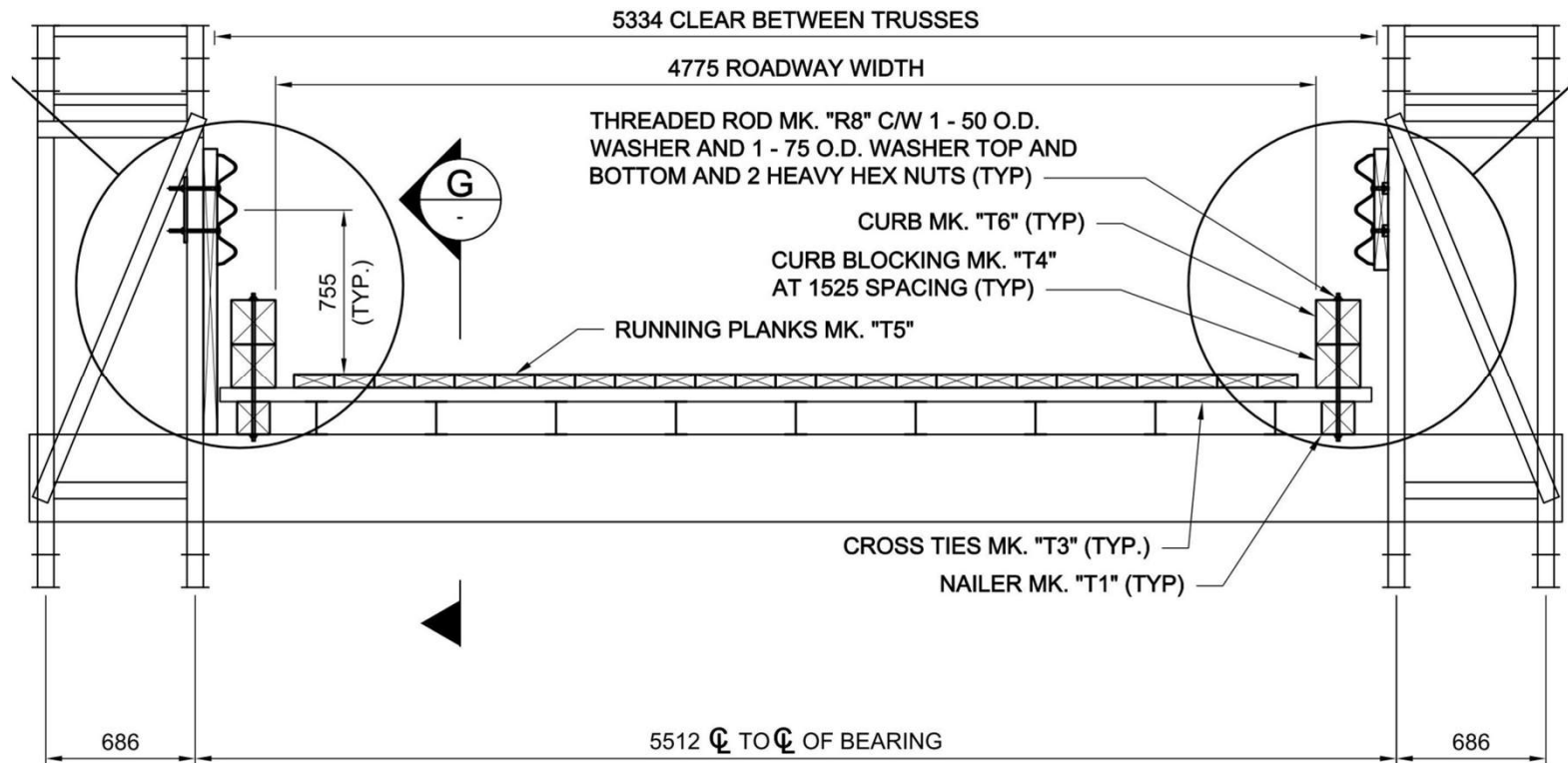



Bridge Over the Falcon River Diversion and Associated Roadworks Bid Opportunity No. 1141-2014

Bidders Conference – January 6, 2015

Timber Deck Details (cont'd):

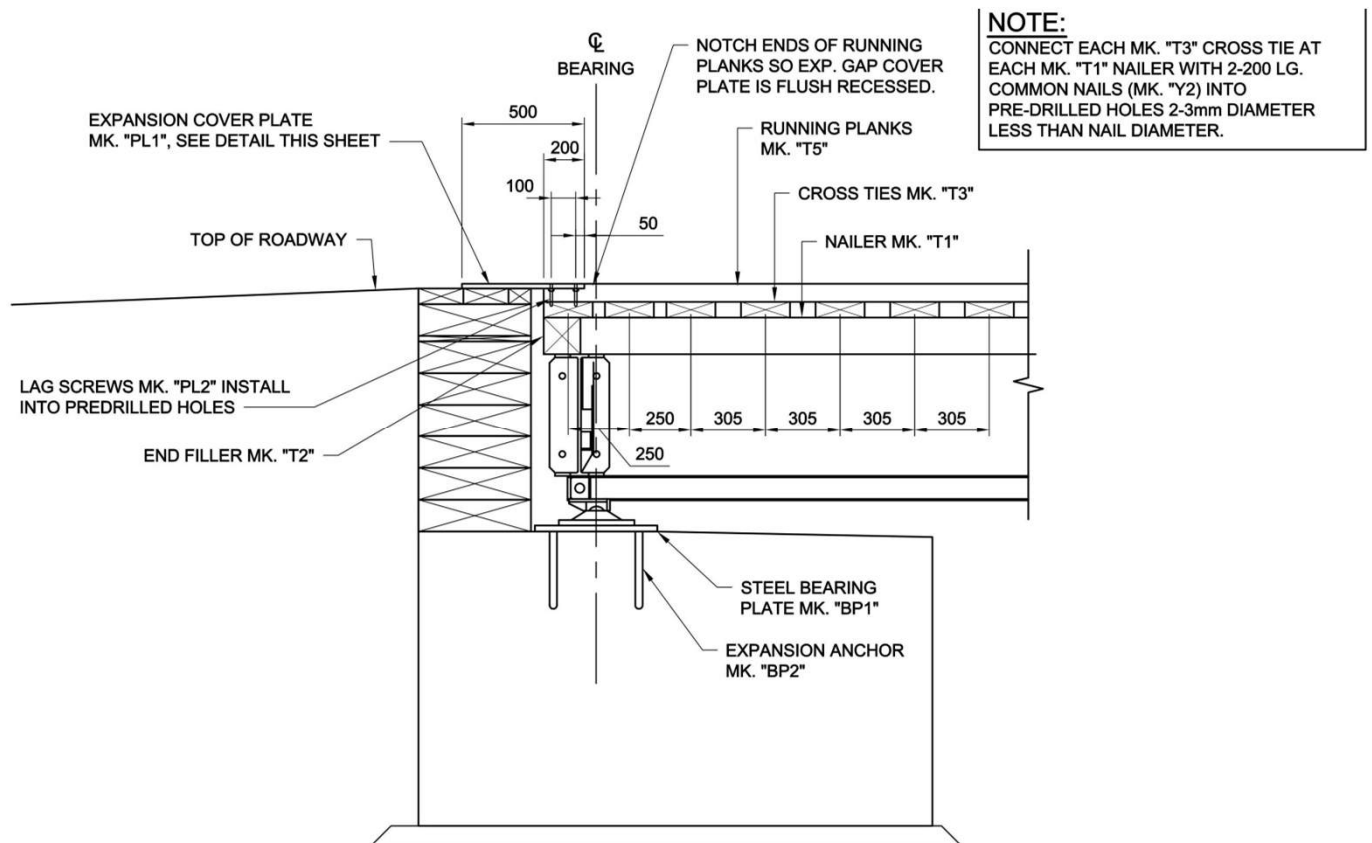



Bridge Over the Falcon River Diversion and Associated Roadworks
Bid Opportunity No. 1141-2014

Bidders Conference – January 6, 2015

Supplemental Conditions:

- Insurance provided by the Contractor (D10):
 - Wrap-up Liability Insurance
 - “All Risk” Builders’ Risk Insurance
- Submissions by Contactor:
 - Safe Work Plan (D9)
 - Detailed Work Schedule (D14)
 - Environmental Protection Plan (D15 & E11)
 - Shoal Lake No. 40 First Nation Involvement (B14 & D24)





Bridge Over the Falcon River Diversion and Associated Roadworks
Bid Opportunity No. 1141-2014

Bidders Conference – January 6, 2015

Substantial and Total Performance (SC14.01 and SC15.01):

- 1) Substantial Performance – **June 30, 2016**
- 2) Total Performance – **July 31, 2016**

Other Key Milestones:

- 1) Installation of steel piles
- 2) Construction of concrete abutments
- 3) Supply and Installation of Acrow panel bridge
- 4) Construction of approach roadway embankments
- 5) Open Acrow panel bridge to traffic





Bridge Over the Falcon River Diversion and Associated Roadworks
Bid Opportunity No. 1141-2014

Bidders Conference – January 6, 2015

Key Specifications:

B14 & D24 Shoal Lake No. 40 First Nations Involvement

- A minimum of \$100,000 of the Work shall be delivered by the Shoal Lake No. 40 First Nation.
- The responsibility of determining the fitness, availability, and reliability of Shoal Lake No. 40 First Nation resources rests with the Contractor.





Bridge Over the Falcon River Diversion and Associated Roadworks
Bid Opportunity No. 1141-2014

Bidders Conference – January 6, 2015

Key Specifications:

B14 & D24 Shoal Lake No. 40 First Nations Involvement (cont'd)

- Shoal Lake No. 40 First Nation representatives

Billy Wahpay, Shoal Lake No. 40 First Nation

Telephone No. (807) 733-2315

Email Address bwahpay@gmail.com

Herb Greene, Shoal Lake No. 40 First Nation

Telephone No. (807) 733-2315

Email Address herb.greene73@gmail.com

Scott Schelske, Bimose Tribal Council

Telephone No. (807) 468-5551

Email Address sschelske@bimose.ca





Bridge Over the Falcon River Diversion and Associated Roadworks
Bid Opportunity No. 1141-2014

Bidders Conference – January 6, 2015

Key Specifications:

E11 Environmental Protection

- No in-water work is permitted.
- Diked fuel storage and refuelling must be located a minimum of 100 m from the waterway



Bridge Over the Falcon River Diversion and Associated Roadworks
Bid Opportunity No. 1141-2014

Bidders Conference – January 6, 2015

Key Specifications:

E12 Work by Others

- The Contractor shall become the Prime Contractor upon entering the site for the first time
- The Contract Administrator will provide survey control points at distances from the bridge site of up to 1 km
- The Contractor is responsible to cooperate with others working in the area which may include:
 - The supply of roadway aggregates approx. 1.2 km's west of the project site.
 - The construction of all weather road from west limit of construction to the Greater Winnipeg Water District (GWWD) railway.





Bridge Over the Falcon River Diversion and Associated Roadworks
Bid Opportunity No. 1141-2014

Bidders Conference – January 6, 2015

Key Specification:

E13 Structural Backfill, Rockfill, Sub Base, Base Course, and Rip Rap material supplied by Shoal Lake No. 40 First Nation.

- The supply of Structural Backfill, Rockfill, Sub Base, Base Course, and Rip Rap material will be included in the Contract as a Cash Allowance and will be paid to the Contractor based on a predetermined unit price agreed upon between the City of Winnipeg and Shoal Lake No. 40 First Nation.





Bridge Over the Falcon River Diversion and Associated Roadworks
Bid Opportunity No. 1141-2014

Bidders Conference – January 6, 2015

Key Specification:

E13 Structural Backfill, Rockfill, Sub Base, Base Course, and Rip Rap material supplied by Shoal Lake No. 40 First Nation (cont'd).

- The Contractor will be required to load at the quarry, haul, place and compact if necessary the applicable material roadway and bridge construction material for each applicable component of bridge and roadway construction.
- The quarry from which the material is to be obtained is at the quarry site located approximately 1,200 m west of the Falcon River Diversion bridge site along the existing quarry access road.





Bridge Over the Falcon River Diversion and Associated Roadworks
Bid Opportunity No. 1141-2014

Bidders Conference – January 6, 2015

Key Specifications:

E21 Acrow Panel Bridge

- The Contractor is required to supply (including design), transport, assemble and erect the Acrow panel bridge.
- The Contractor will be required to supply new, galvanized components to construct 1 – 36.58 m. span 700XS Acrow panel bridge with a roadway width (curb-to-curb) of 4.78m. and a clear width between trusses of 5.32m.
- The bridge shall include steel stringers to accommodate a timber deck.
- The bridge shall be designed according to the CAN/CSA-S6-06 Canadian Highway Bridge Design Code including all interims for the CL 625 design live load.





Bridge Over the Falcon River Diversion and Associated Roadworks
Bid Opportunity No. 1141-2014

Bidders Conference – January 6, 2015

Key Specification:

E21 Acrow Panel Bridge (cont'd)

- The Contractor will be responsible for providing an Acrow Representative to assist with the planning, material assembly, launch design, launching, and erection of the Acrow Panel Bridge.
- Example of Acrow Bridge Construction
 - https://www.youtube.com/watch?v=h_eJRX5iVnc&list=PLvqXTqcYDg_cpd6uzJZmqbADH88I3YT3t&index=2





Bridge Over the Falcon River Diversion and Associated Roadworks
Bid Opportunity No. 1141-2014

Bidders Conference – January 6, 2015

Key Specifications:

E22 Supply and Install Timber Decks, Backwalls, and Wingwalls

- The timber shall be Coastal Douglas Fir #2, or better; structural full sawn and treated. All timber shall be inspected by a certified inspection company after treatment.
- Backwalls shall be constructed of glulam timber beams.
- The timber decking shall be planed on two (2) edges and one side and laid heart side down.





Bridge Over the Falcon River Diversion and Associated Roadworks
Bid Opportunity No. 1141-2014

Bidders Conference – January 6, 2015

Key Specification:

E32 Winter Road Cash Allowance

- Access to the site to complete the Work is the sole responsibility of the Contractor.
- A Cash Allowance is included for the construction of the winter road from TCH #1 to Shoal Lake No. 40 First Nation for the 2014/2015 winter road season.
- A cash allowance has not been included for the 2015/2016 winter road season.





Bridge Over the Falcon River Diversion and Associated Roadworks Bid Opportunity No. 1141-2014

Bidders Conference – January 6, 2015

Existing Winter Road

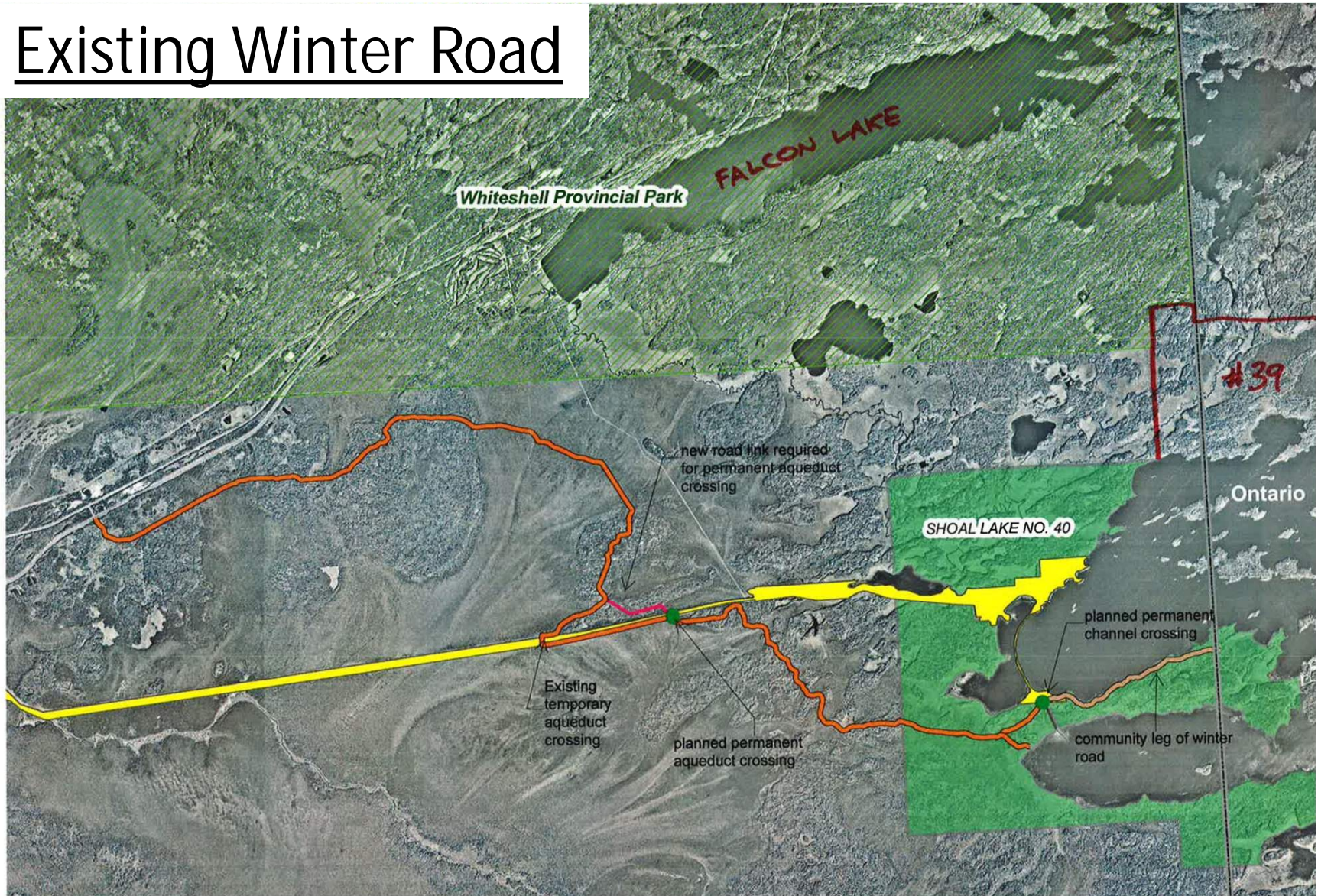



Bridge Over the Falcon River Diversion and Associated Roadworks
Bid Opportunity No. 1141-2014

Bidders Conference – January 6, 2015

Existing Bridge

- Existing Crossing Falcon River Diversion owned by Shoal Lake No. 40





Bridge Over the Falcon River Diversion and Associated Roadworks
Bid Opportunity No. 1141-2014

Bidders Conference – January 6, 2015

Questions?

