

David Wagner Associates Inc.

4 - 430 River Avenue Winnipeg, Manitoba, R3L 0C6 (204) 452-2426
LANDSCAPE ARCHITECTURE • URBAN DESIGN • GOLF COURSE ARCHITECTURE

Location of underground structures as shown are based on the best information available but no guarantee is given that all existing utilities are shown or that the given locations are exact. Confirmation of existence and exact location of all services must be obtained from the individual utilities before proceeding with construction.

DO NOT SCALE - DRAWING PLOT MAY NOT BE AT 100%

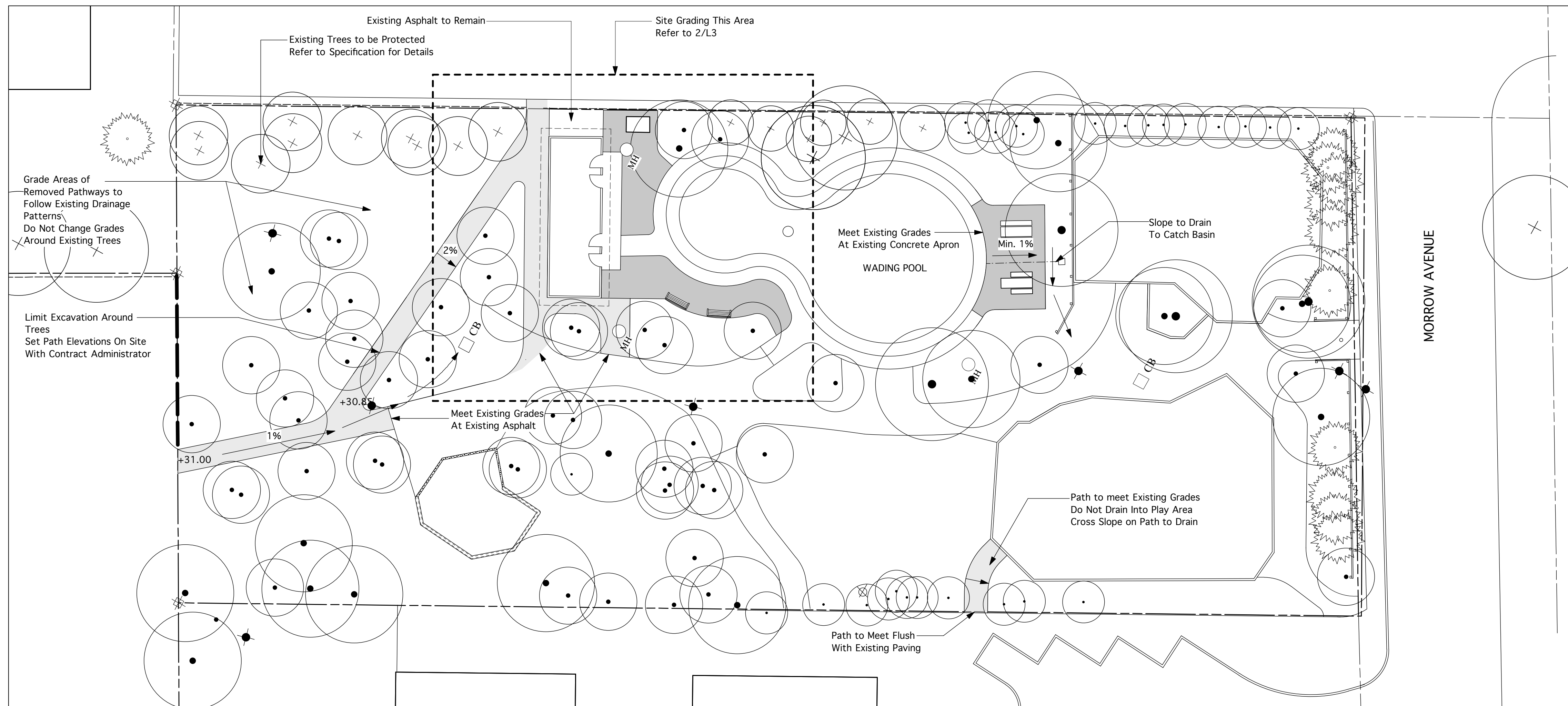

LEGEND
+ 30.14 Existing Grades (metric)
+ 30.14 Proposed Grades
Refer to L1 for Existing Grades

1 GRADING SCHEMATIC
L3 Scale: 1:200

SITE SURVEY BY
GENEVAR
MAY 24, 2013

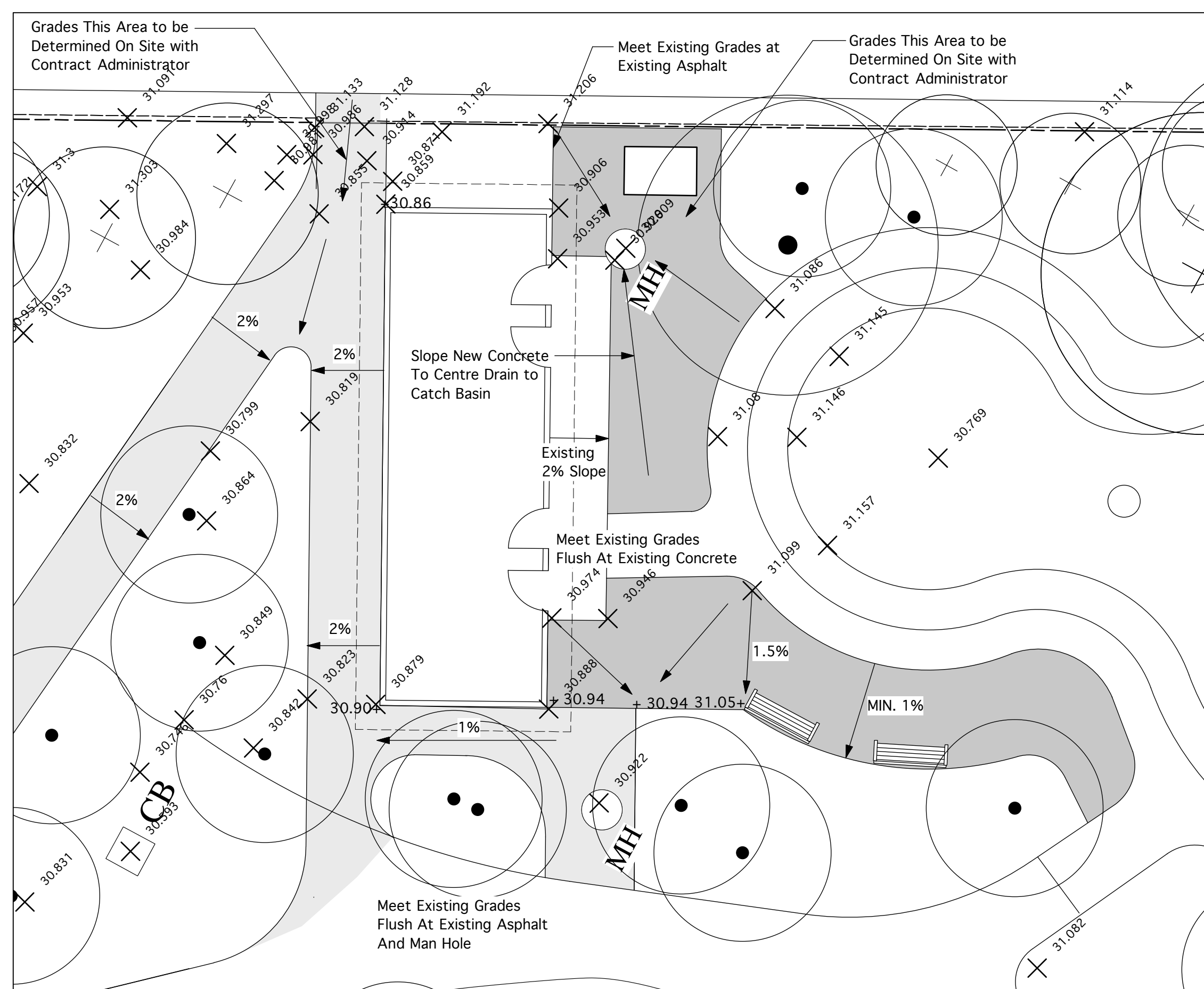
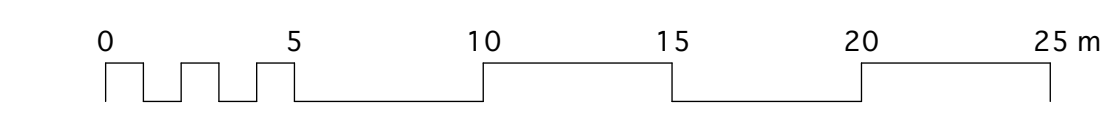
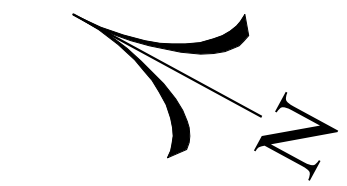

2 GRADING SCHEMATIC DETAIL
L3 Scale: 1:100

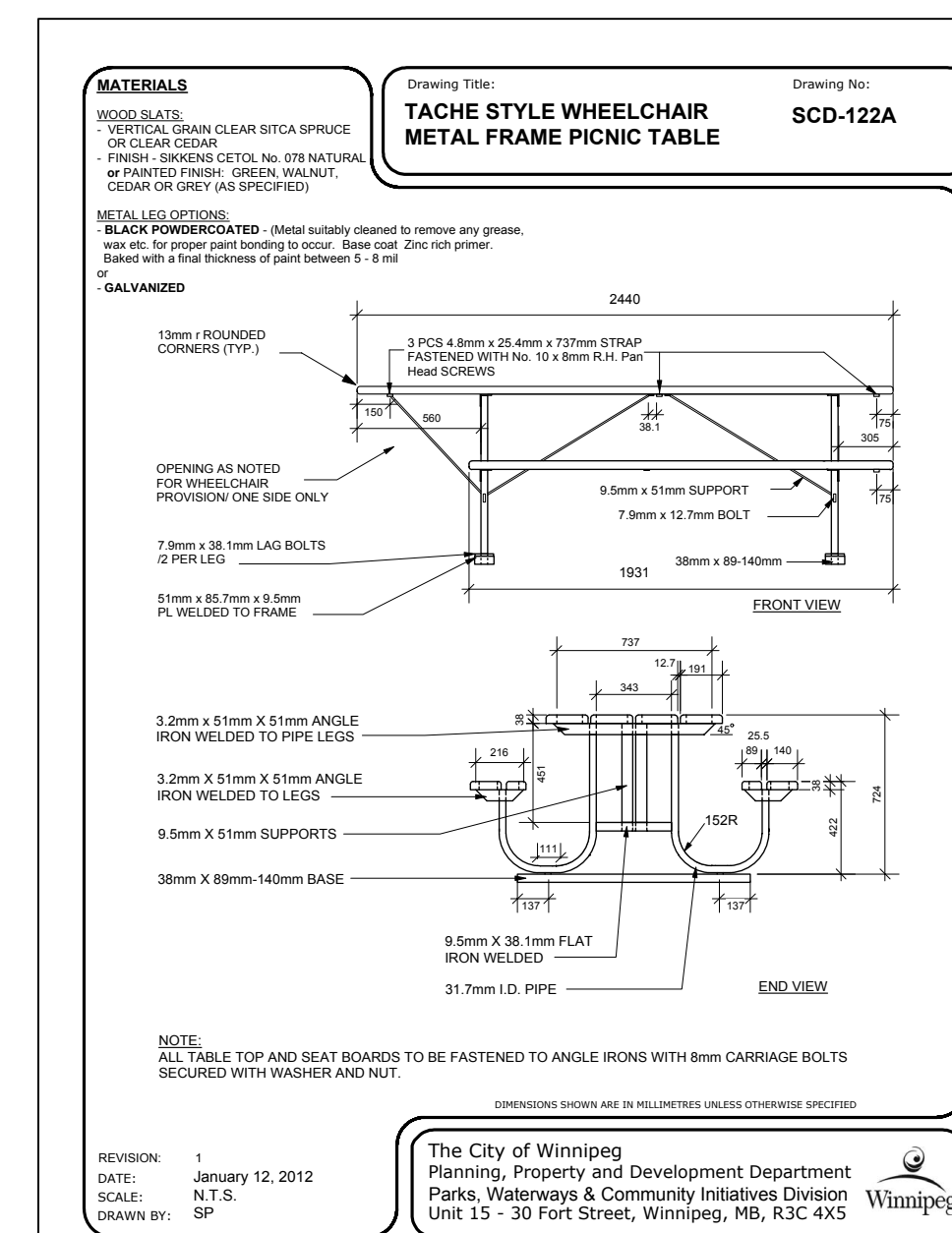

3 PICNIC TABLES
L3

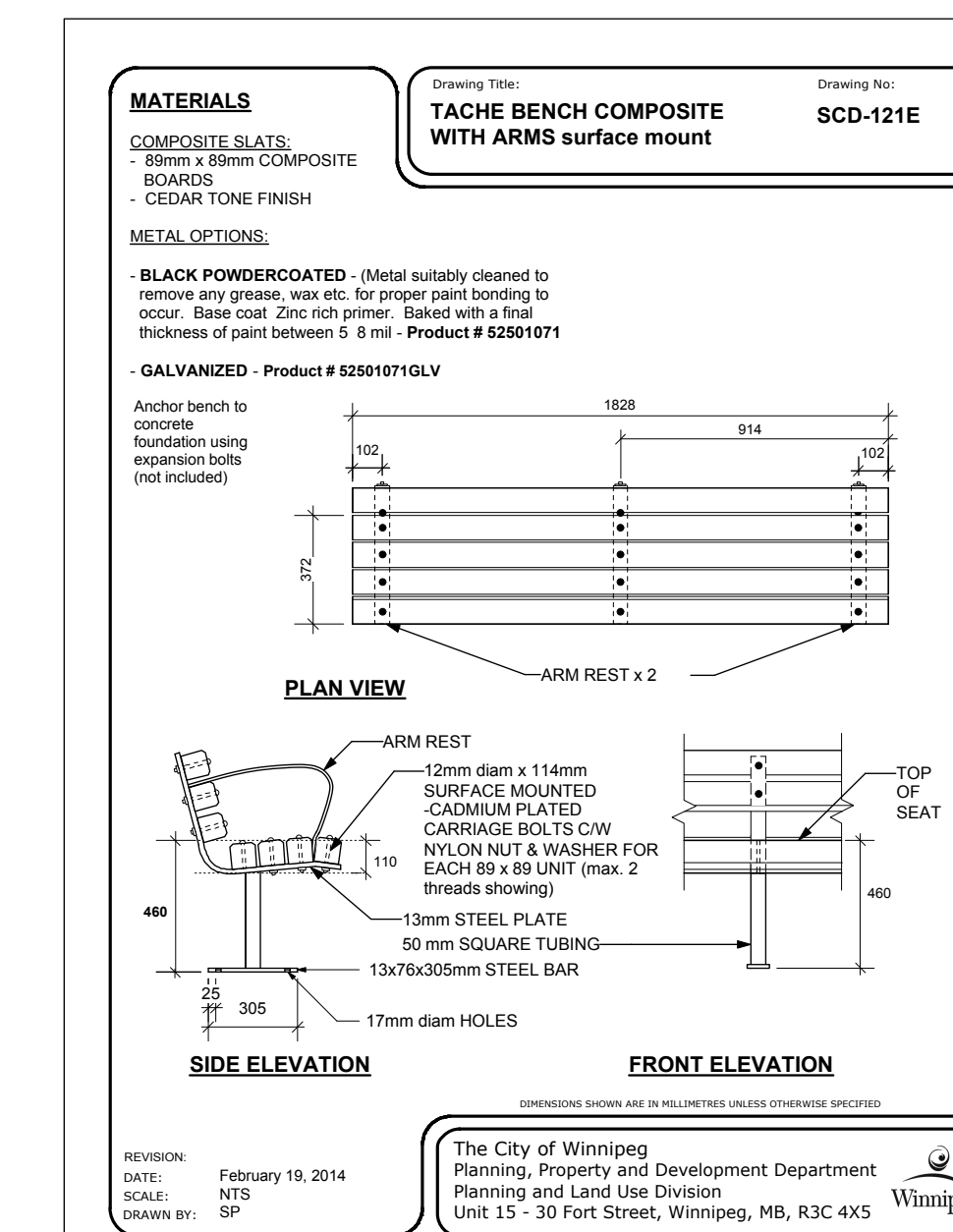
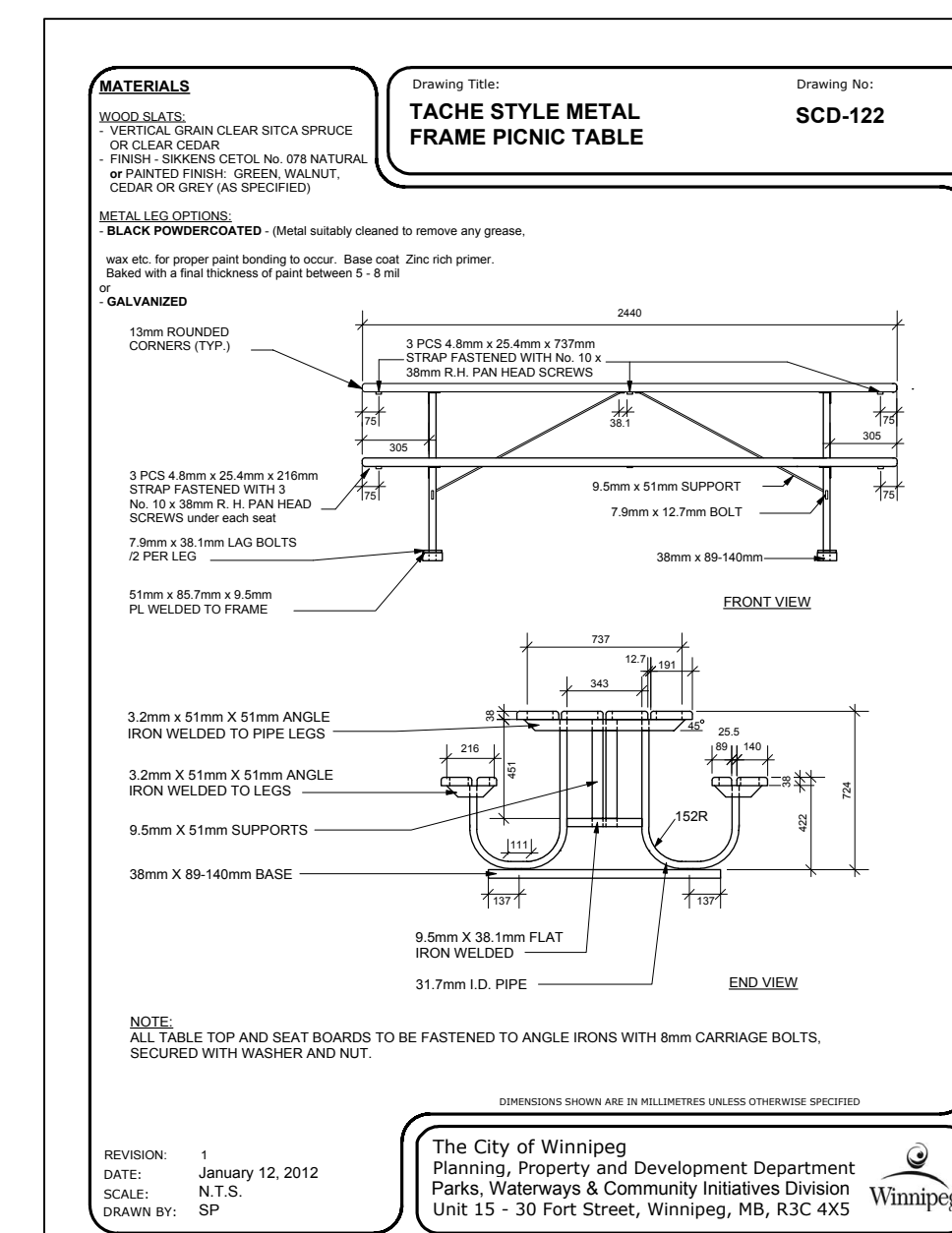

4 TACHE BENCHES
L3

RELEASED FOR CONSTRUCTION	DATE: XX Month, 20XX
7	
6	
5	
4	
3	
2	
1	
NO. REVISION	DATE BY

BCI II - PHASE TWO



DUCHARME PARK
SITE IMPROVEMENTS - PHASE TWO
MORROW AVENUE

DRAWN BY: LLW DATE: 4 MARCH, 2014
APPROVED BY: DW SCALE: AS SHOWN

GRADING SCHEMATIC PLAN AND DETAILS

PROJECT NO.	SHEET NO.	REVISION NO.
1310	L3	0