

CONSTRUCTION NOTES:

1. ALL DIMENSIONS ARE TO BACK OF CURB.
2. ISOLATE MISCELLANEOUS ITEMS IN NEW CONCRETE WORKS AS PER SD-228C.
3. LEGAL PLAN AND UNDERGROUND INFORMATION FROM CITY OF WINNIPEG LBIS. CONTRACTOR TO VERIFY ALL UNDERGROUNDS IN THE FIELD.
4. CONTRACTOR TO TAKE PRECAUTIONARY STEPS TO AVOID DAMAGE FROM CONSTRUCTION ACTIVITIES TO TREES WITHIN THE LIMITS OF CONSTRUCTION.
5. LOCATION OF EXISTING SERVICES TO BE CONFIRMED IN THE FIELD BY THE CONTRACTOR.
6. CB LEADS TO BE INSTALLED AT MIN. 1.0% SLOPE OR AS DIRECTED BY CONTRACT ADMINISTRATOR.
7. LIMITS OF SIDEWALK RENEWAL TO BE FINALIZED IN THE FIELD BY THE CONTRACT ADMINISTRATOR.
8. LIMITS OF BOULEVARD GRADING TO BE FINALIZED IN THE FIELD BY THE CONTRACT ADMINISTRATOR.

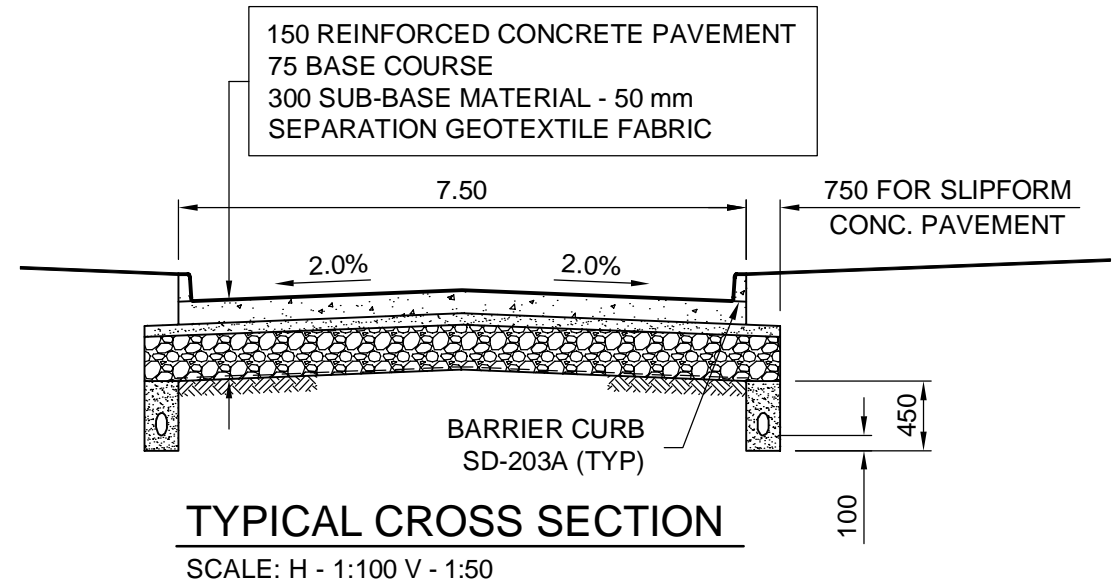
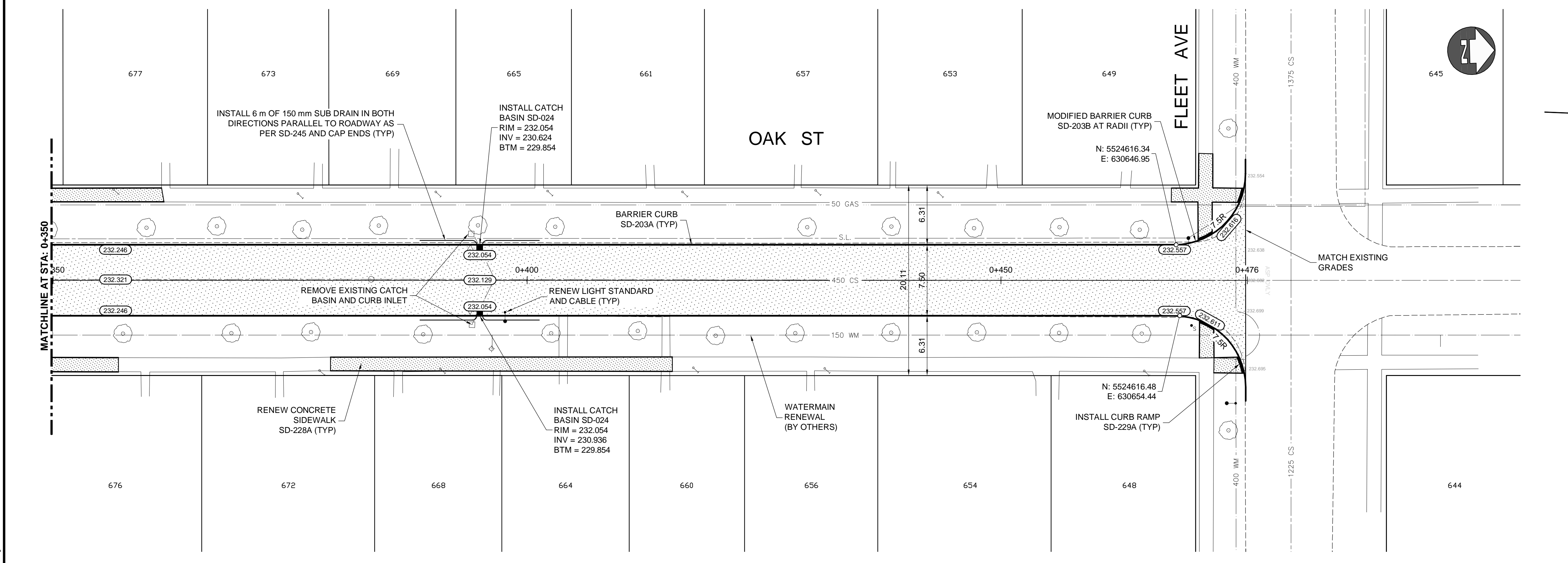

METRIC

WHOLE NUMBERS INDICATE MILLIMETRES
DECIMALIZED NUMBERS INDICATE METRES

WARNING

IF POWER EQUIPMENT OR EXPLOSIVES ARE TO BE USED FOR EXCAVATION ON THIS PROJECT THE CONTRACTOR MUST:

1. NOTIFY THE GAS COMPANY OF THE PROPOSED LOCATION OF EXCAVATION.
2. TAKE PRECAUTION TO AVOID DAMAGE TO GAS COMPANY INSTALLATIONS SEE PROVINCIAL REGULATION 210/72 FOR DETAILS.
3. OBTAIN EXCAVATION PERMITS PRIOR TO CONSTRUCTION.



Certificate of Authorization
Dillon Consulting Limited (MB)
No. 1789 Date: 04/22/2014

150 WM	WATERMAIN	150 WM	HYDRO	HYDRO	HYDRO	150 WM	WATERMAIN	150 WM
300 LDS	LAND DRAINAGE SEWER	300 LDS	MTS	M.T.S.	MTS	300 LDS	LAND DRAINAGE SEWER	300 LDS
250 WWS	WASTE WATER SEWER	250 WWS	CONCRETE	CONCRETE	CONCRETE	250 WWS	WASTE WATER SEWER	250 WWS
MANHOLE	MANHOLE	MANHOLE	ASPHALT	ASPHALT	ASPHALT	MANHOLE	MANHOLE	MANHOLE
CATCH BASIN	CATCH BASIN	CATCH BASIN	PLANING	PLANING	PLANING	CATCH BASIN	CATCH BASIN	CATCH BASIN
CURB INLET	CURB INLET	CURB INLET	SIDEWALK	SIDEWALK	SIDEWALK	CURB INLET	CURB INLET	CURB INLET
JUNCTIONS	JUNCTIONS	JUNCTIONS	PAVING STONES	PAVING STONES	PAVING STONES	JUNCTIONS	JUNCTIONS	JUNCTIONS
CULVERT	CULVERT	CULVERT	PARTIAL DEPTH REPAIR	PARTIAL DEPTH REPAIR	PARTIAL DEPTH REPAIR	CULVERT	CULVERT	CULVERT
100 GAS	GAS	100 GAS	PROPERTY LINE	PROPERTY LINE	PROPERTY LINE	100 GAS	GAS	100 GAS
EXISTING	LEGEND-PLAN	PROPOSED	EXISTING	LEGEND-PLAN	PROPOSED	EXISTING	LEGEND-PROFILE	PROPOSED

UNDERGROUND STRUCTURES	B.M. ELEV.
SUPV. U/G STRUCTURES	DATE
LOCATION OF UNDERGROUND STRUCTURES AS SHOWN ARE BASED ON THE BEST INFORMATION AVAILABLE, BUT NO GUARANTEE IS GIVEN THAT ALL EXISTING UTILITIES ARE SHOWN OR THAT THE GIVEN LOCATIONS ARE EXACT. CONFIRMATION OF EXISTENCE AND EXACT LOCATION OF ALL SERVICES MUST BE OBTAINED FROM THE INDIVIDUAL UTILITIES BEFORE PROCEEDING WITH CONSTRUCTION.	

DESIGNED BY	AMC
DRAWN BY	TJH
CHECKED BY	ORIGINAL SIGNED BY TARAN J. PETERS
APPROVED BY	ORIGINAL SIGNED BY DAVID B. WIEBE
HOR. SCALE	1:250
VERTICAL	1:10
RELEASSED FOR CONSTRUCTION	DATE
NO. REVISIONS	DATE BY

DATE	04/22/2014
------	------------



ENGINEER'S SEAL
PROVINCE OF MANITOBA
REGISTERED PROFESSIONAL ENGINEER
T.J. PETERS
04/22/2014
Member 22309

THE CITY OF WINNIPEG
PUBLIC WORKS DEPARTMENT

2014 RESIDENTIAL STREET RENEWAL PROGRAM

PLAN-PROFILE - OAK STREET - STA. 0+350 TO FLEET AVENUE

CITY DRAWING NUMBER
SHEET 05 OF 14
CONSULTANT DRAWING NUMBER

CONSULTANT PROJECT NUMBER
13-8775

GA:\CAD\138775\Contract\Plan-Profile-Oak.dwg