

A1 SIZE 894mm x 841mm  
PLOT: 6277/2014.10.36.05 AM  
FILE NAME: W140002-T-001\_RX.dwg Saved By: diane

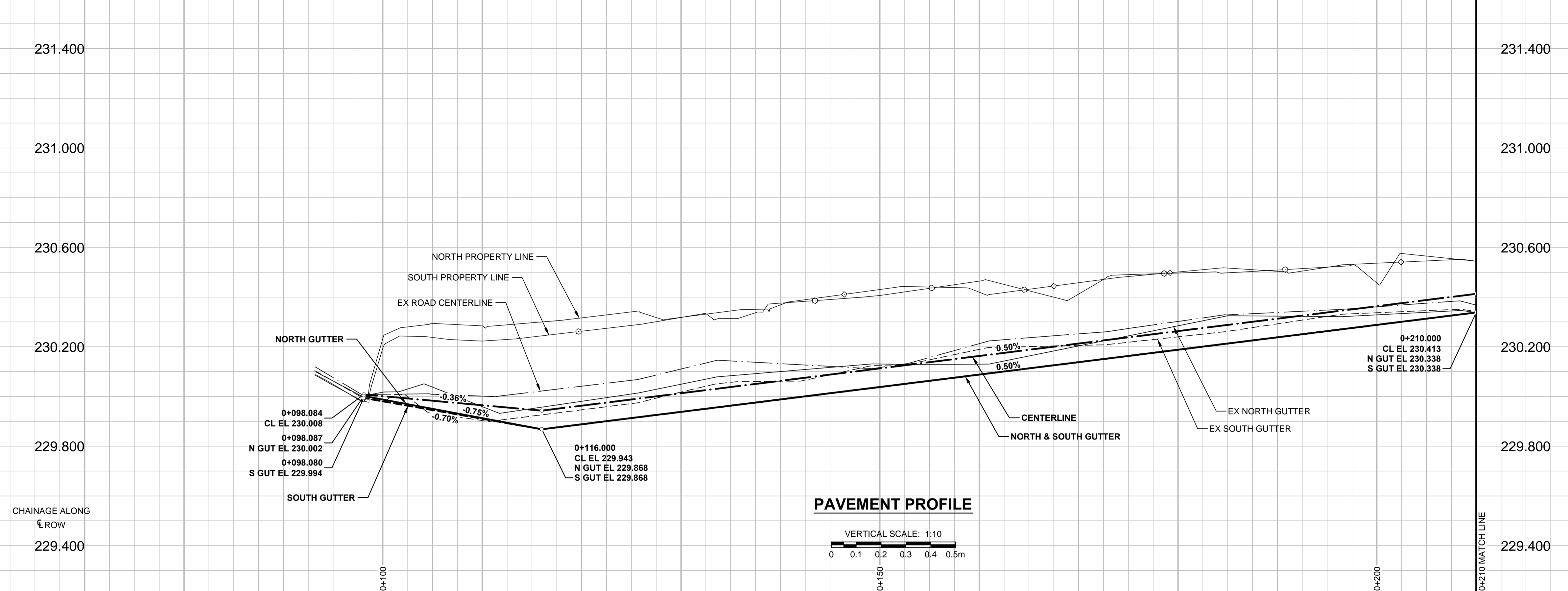

CENTERLINE-GEOMETRIC CONTROL POINT COORDINATES		
POINT/STATION	NORTHING	EASTING
POT 0+070.000	9992.056	9970.005
POT 0+098.084	9998.089	9992.074

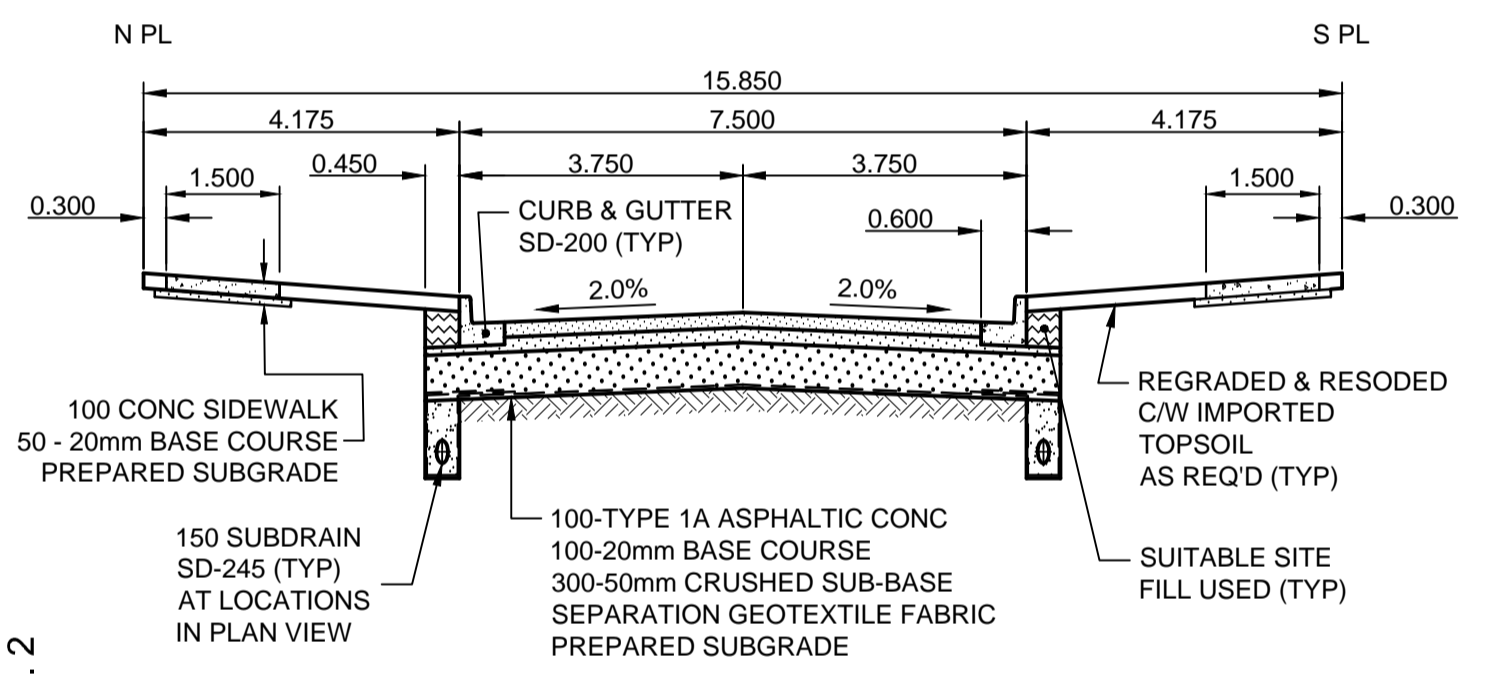
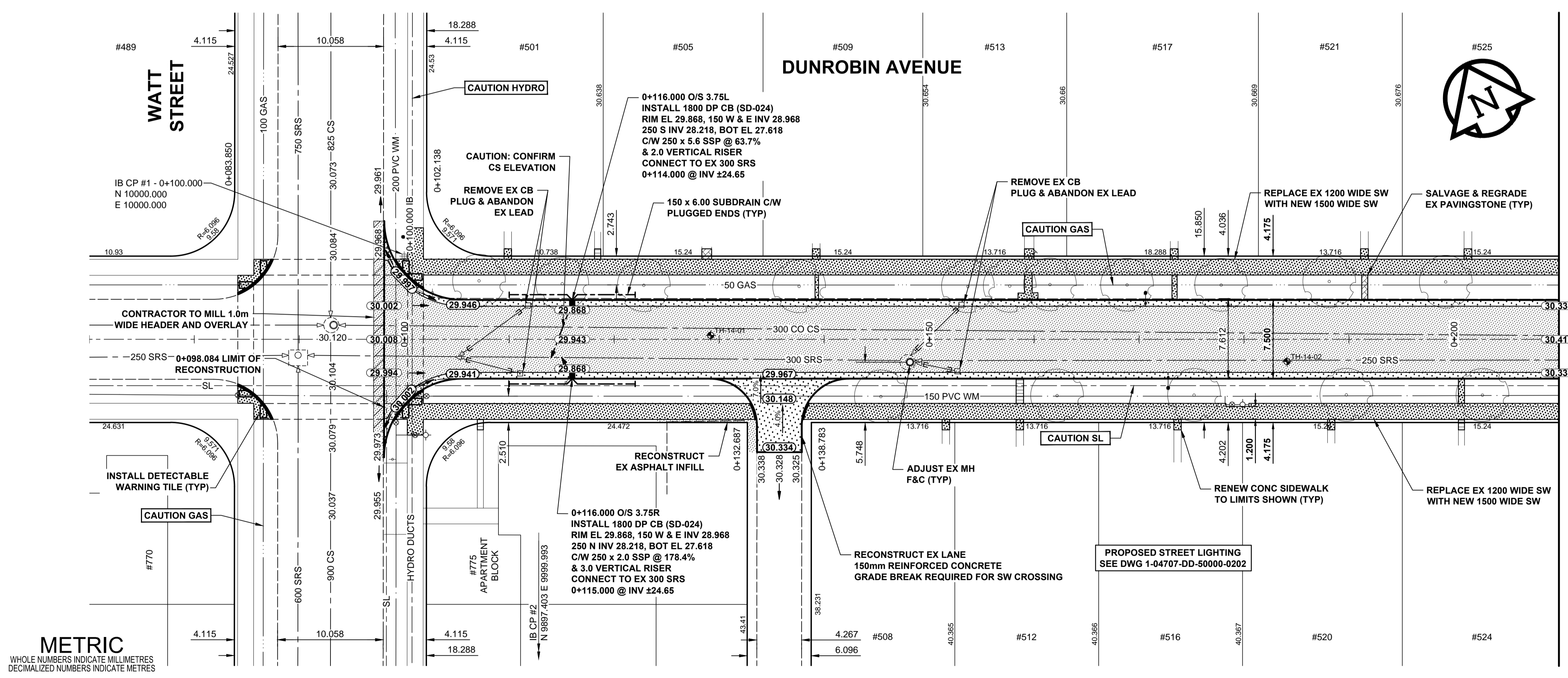

**PAVEMENT SECTION**  
ASPHALT PAVEMENT STRUCTURE  
TYPICAL  
SCALE: N.T.S.

- NOTES**
- ADJUST MH AND CB RIMS TO NEW GRADES.
  - CONTRACTOR TO REGRADE/RENEW EXIST PRIVATE SIDEWALKS TO LIMITS AS SHOWN. SIDEWALKS TO BE RENEWED WITH CONCRETE UNLESS NOTED OTHERWISE.
  - CONTRACTOR TO TAKE PRECAUTIONARY STEPS TO PROTECT EXISTING TREES WITHIN THE LIMITS OF CONSTRUCTION FROM DAMAGE FROM CONSTRUCTION ACTIVITIES AS OUTLINED IN THE SPECIFICATIONS.
  - MODIFIED BARRIER CURB TO BE USED AT ALL INTERSECTION RADII, BACK LANE RADII AND BULLNOSES.
  - CONTRACTOR TO CONFIRM THE LOCATION OF ALL UTILITIES/SERVICES IN THE FIELD PRIOR TO CONSTRUCTION.
  - ADD 200.000m TO ABBREVIATED ELEVATIONS TO OBTAIN GEODETIC ELEVATIONS.
  - CB SD-024 OFFSETS ARE DIMENSIONED TO BOC. CB SD-025 OFFSETS ARE DIMENSIONED O/C.

GAS		MANHOLE		CONCRETE PAVEMENT	
MTS	○	CATCH BASIN / CATCH PIT	●	CONC SIDEWALK / MEDIAN	▨
HYDRO	△	CURB INLET WITH BOX	▲	ASPHALT PAVEMENT	▩
CATV / FIBRE OPTIC	⊕	TREE	⊙	PAVING STONE	▧
TRAFFIC SIGNALS / PIT	⊕	TEST HOLE	⊕	GRAVEL	▩
LAND DRAINAGE SEWER	⊕	PROPERTY LINE	---	RAMP CURB	▩
SANITARY/COMBINED SEWER	⊕	SURVEY BAR	---	PLANING / REMOVAL	▩
SEWER SERV/DRAINAGE CONN	⊕	FENCE	---		
WATERMAIN	⊕	BOC / EDGE OF PAVEMENT	---		
SUBDRAIN	⊕	ELEVATION	(33.100)		
DITCH	⊕	TRAFFIC SIGN			
EXISTING	LEGEND - PLAN	NEW	EXISTING	LEGEND - PLAN	NEW

**LOCATION APPROVED UNDERGROUND STRUCTURES**

SUPR. U/G STRUCTURES DATE COMMITTEE

**NOTE:**  
LOCATION OF UNDERGROUND STRUCTURES AS SHOWN ARE BASED ON THE BEST INFORMATION AVAILABLE. BUT NO GUARANTEE IS GIVEN THAT ALL EXISTING UTILITIES ARE SHOWN OR THAT THE GIVEN LOCATIONS ARE EXACT. CONFIRMATION OF EXISTENCE AND EXACT LOCATION OF ALL SERVICES MUST BE OBTAINED FROM THE INDIVIDUAL UTILITIES BEFORE PROCEEDING WITH CONSTRUCTION.

GBM 12-062 ELEV 230.128			
DESIGNED BY	RPB	CHECKED BY	WRJ
DRAWN BY	DID/DML	APPROVED BY	BWB
HOR. SCALE	1:250	RELEASED FOR CONSTRUCTION	
VERT. SCALE	1:10	DATE	June 26/14
DATE	14/06/25		

**MORRISON HERSHFIELD**

DESIGNED BY: RPB  
DRAWN BY: DID/DML  
DATE: 14/06/25

CHECKED BY: WRJ  
APPROVED BY: BWB  
DATE: June 26/14

PROFESSIONAL'S SEAL

PROVINCE OF MANITOBA  
REGISTERED PROFESSIONAL ENGINEER

R.P. BRUCE

CONSULTANT DRAWING No. W140002-T-001\_RX.dwg

**THE CITY OF WINNIPEG**  
PUBLIC WORKS DEPARTMENT  
ENGINEERING DIVISION

**2014 LOCAL STREETS PACKAGE**  
DUNROBIN AVENUE  
WATT STREET TO GOLSPIE STREET  
ASPHALT RECONSTRUCTION  
HORIZONTAL AND VERTICAL ALIGNMENT  
STA 0+070 TO STA 0+210

CITY DRAWING NUMBER: N/A  
SHEET 1 OF 20  
DRAWING No. 1  
REV 0

BID OPPORTUNITY No. 622-2014