

A1 SIZE 894mm x 841mm  
PLOT: 6272/2014.10.36.45 AM  
FILE NAME: W140002-T-003\_RX.dwg Saved By: diane

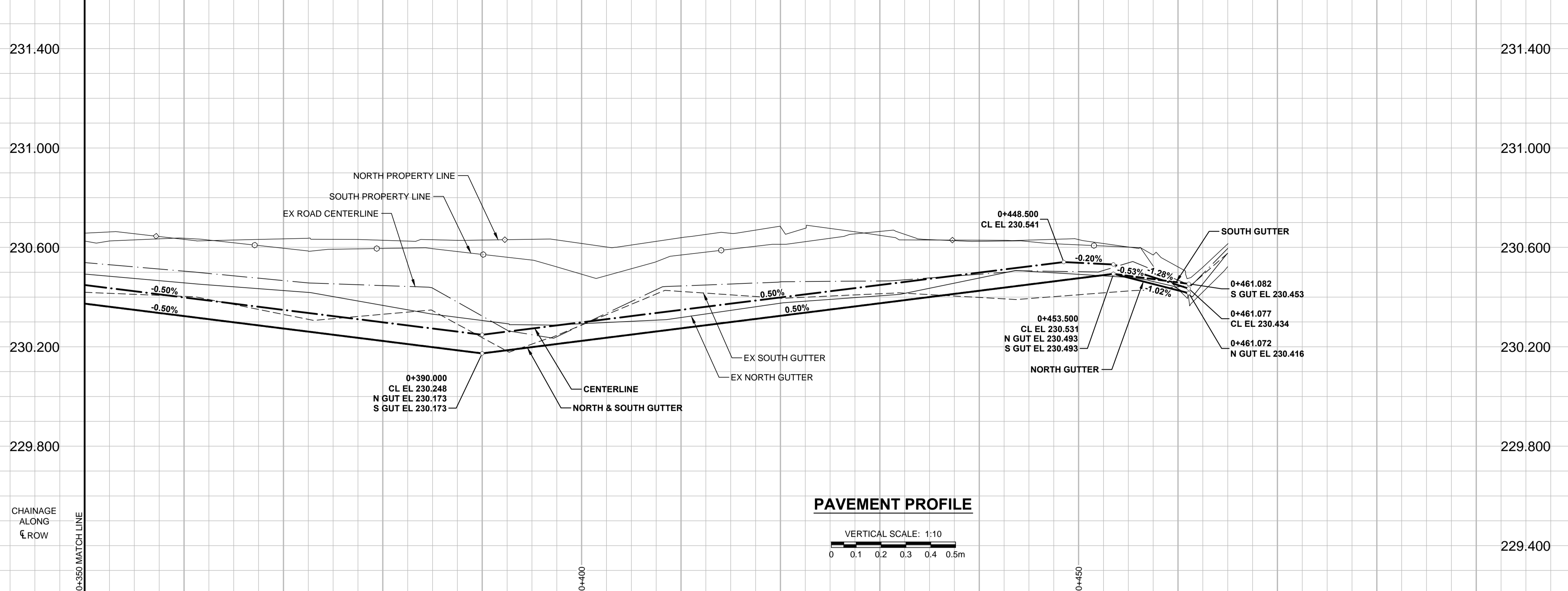

CENTERLINE-GEOMETRIC CONTROL POINT COORDINATES		
POINT/STATION	NORTHING	EASTING
POT 0+461.077	9992.304	10361.082
POT 0+490.000	9992.323	10390.005

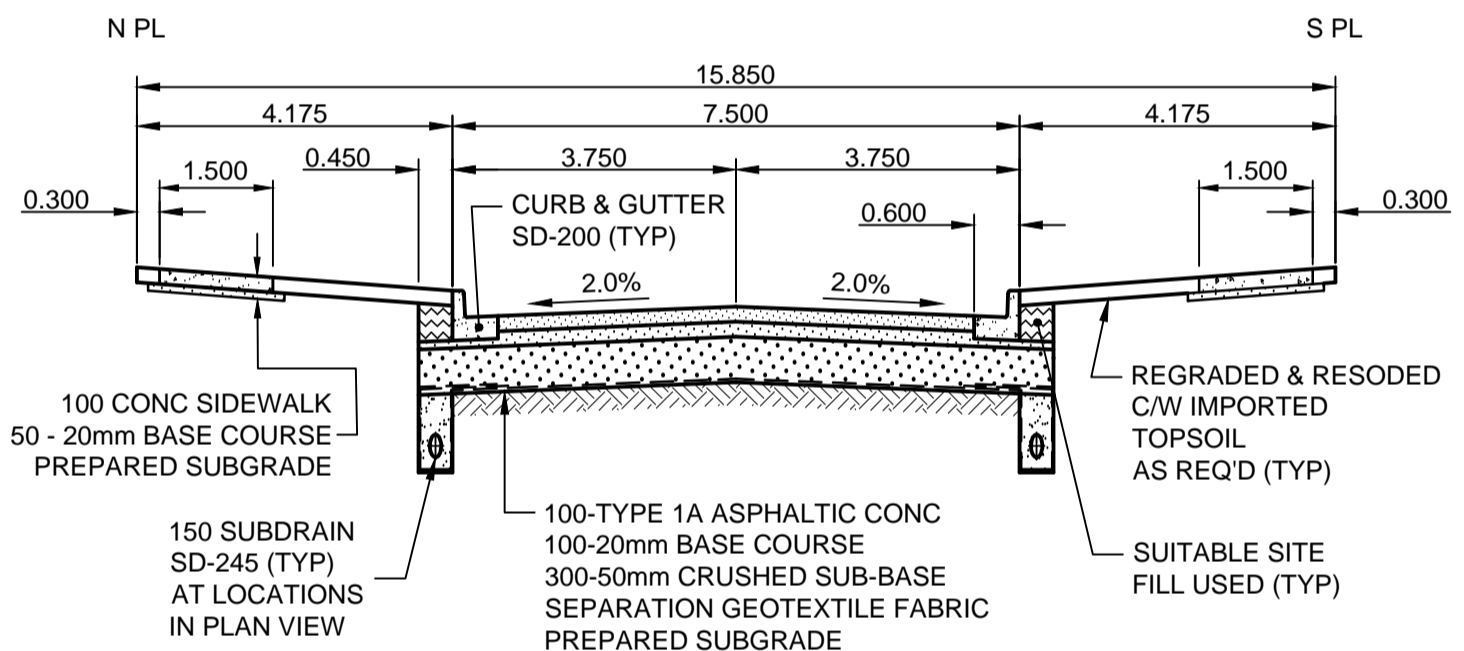
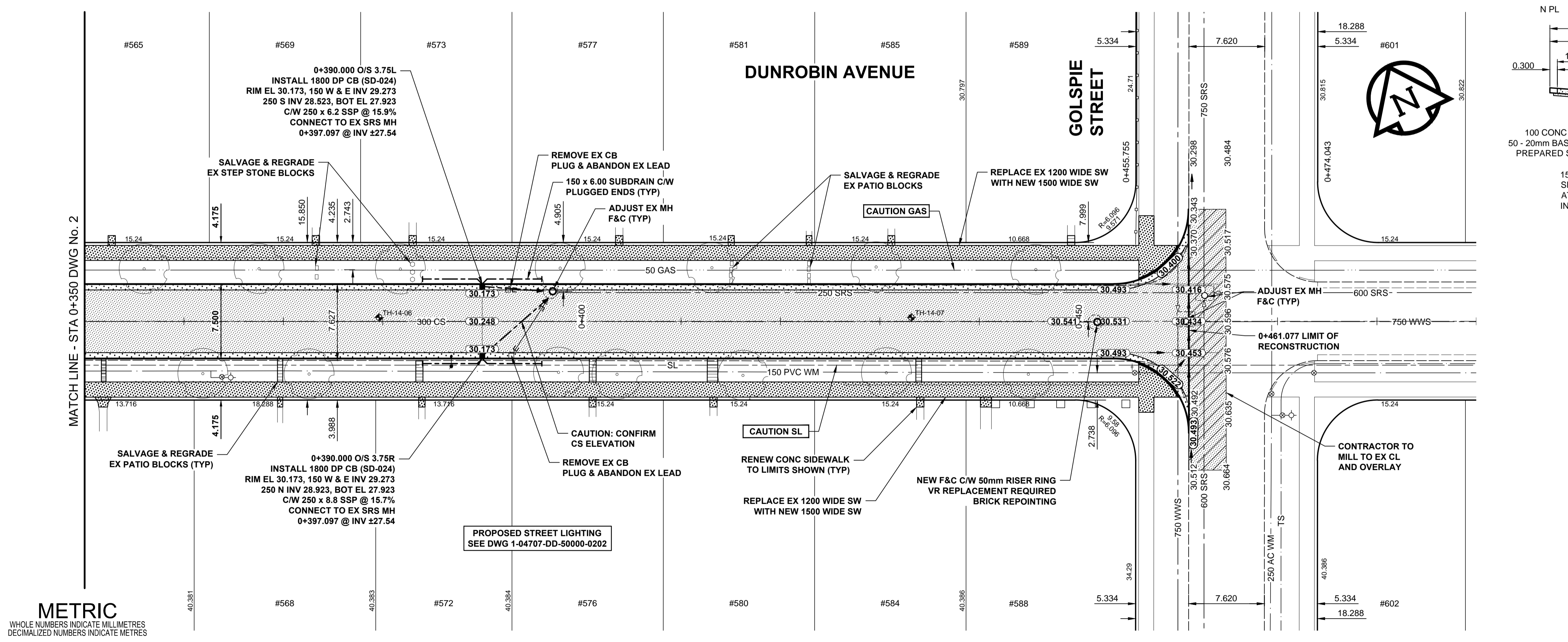

**PAVEMENT SECTION**  
ASPHALT PAVEMENT STRUCTURE  
TYPICAL  
SCALE: N.T.S.

- NOTES**
- ADJUST MH AND CB RIMS TO NEW GRADES.
  - CONTRACTOR TO REGRADE/RENEW EXIST PRIVATE SIDEWALKS TO LIMITS AS SHOWN. SIDEWALKS TO BE RENEWED WITH CONCRETE UNLESS NOTED OTHERWISE.
  - CONTRACTOR TO TAKE PRECAUTIONARY STEPS TO PROTECT EXISTING TREES WITHIN THE LIMITS OF CONSTRUCTION FROM DAMAGE FROM CONSTRUCTION ACTIVITIES AS OUTLINED IN THE SPECIFICATIONS.
  - MODIFIED BARRIER CURB TO BE USED AT ALL INTERSECTION RADII, BACK LANE RADII AND BULLNOSES.
  - CONTRACTOR TO CONFIRM THE LOCATION OF ALL UTILITIES/SERVICES IN THE FIELD PRIOR TO CONSTRUCTION.
  - ADD 200.000m TO ABBREVIATED ELEVATIONS TO OBTAIN GEODETIC ELEVATIONS.
  - CB SD-024 OFFSETS ARE DIMENSIONED TO BOC. CB SD-025 OFFSETS ARE DIMENSIONED O/C.

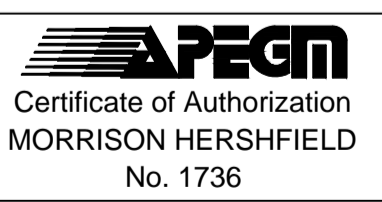

BID OPPORTUNITY No. 622-2014

**METRIC**  
WHOLE NUMBERS INDICATE MILLIMETRES  
DECIMALIZED NUMBERS INDICATE METRES

EXISTING	LEGEND - PLAN	NEW	EXISTING	LEGEND - PLAN	NEW	EXISTING	LEGEND - PLAN	NEW	
	GAS		MANHOLE		CONCRETE PAVEMENT		LOCATION APPROVED		UG STRUCTURES
	MTS		CATCH BASIN / CATCH PIT		CONC SIDEWALK / MEDIAN		DATE		SUPR. UG STRUCTURES
	HYDRO		CURB INLET WITH BOX		ASPHALT PAVEMENT		COMMITTEE		NOTE:
	CATV / FIBRE OPTIC		TREE		PAVING STONE		LOCATION OF UNDERGROUND STRUCTURES AS SHOWN ARE BASED ON THE BEST INFORMATION AVAILABLE. BUT NO GUARANTEE IS GIVEN THAT ALL EXISTING UTILITIES ARE SHOWN OR THAT THE GIVEN LOCATIONS ARE EXACT. CONFIRMATION OF EXISTENCE AND EXACT LOCATION OF ALL SERVICES MUST BE OBTAINED FROM THE INDIVIDUAL UTILITIES BEFORE PROCEEDING WITH CONSTRUCTION.		GRAVEL
	TRAFFIC SIGNALS / PIT		TEST HOLE		RAMP CURB		INFORMATION AVAILABLE. BUT NO GUARANTEE IS GIVEN THAT ALL EXISTING UTILITIES ARE SHOWN OR THAT THE GIVEN LOCATIONS ARE EXACT. CONFIRMATION OF EXISTENCE AND EXACT LOCATION OF ALL SERVICES MUST BE OBTAINED FROM THE INDIVIDUAL UTILITIES BEFORE PROCEEDING WITH CONSTRUCTION.		PLANING / REMOVAL
	LAND DRAINAGE SEWER		PROPERTY LINE		SURVEY BAR		DATE		NOTE:
	SANITARY/COMBINED SEWER		SURVEY BAR		FENCE		LOCATION OF UNDERGROUND STRUCTURES AS SHOWN ARE BASED ON THE BEST INFORMATION AVAILABLE. BUT NO GUARANTEE IS GIVEN THAT ALL EXISTING UTILITIES ARE SHOWN OR THAT THE GIVEN LOCATIONS ARE EXACT. CONFIRMATION OF EXISTENCE AND EXACT LOCATION OF ALL SERVICES MUST BE OBTAINED FROM THE INDIVIDUAL UTILITIES BEFORE PROCEEDING WITH CONSTRUCTION.		GRAVEL
	SEWER SERV/DRAINAGE CONN		BOC / EDGE OF PAVEMENT		ELEVATION		INFORMATION AVAILABLE. BUT NO GUARANTEE IS GIVEN THAT ALL EXISTING UTILITIES ARE SHOWN OR THAT THE GIVEN LOCATIONS ARE EXACT. CONFIRMATION OF EXISTENCE AND EXACT LOCATION OF ALL SERVICES MUST BE OBTAINED FROM THE INDIVIDUAL UTILITIES BEFORE PROCEEDING WITH CONSTRUCTION.		PLANING / REMOVAL
	WATERMAIN		TRAFFIC SIGN		NOTE:		DATE		NOTE:
	SUBDRAIN		NOTE		DATE		INFORMATION AVAILABLE. BUT NO GUARANTEE IS GIVEN THAT ALL EXISTING UTILITIES ARE SHOWN OR THAT THE GIVEN LOCATIONS ARE EXACT. CONFIRMATION OF EXISTENCE AND EXACT LOCATION OF ALL SERVICES MUST BE OBTAINED FROM THE INDIVIDUAL UTILITIES BEFORE PROCEEDING WITH CONSTRUCTION.		PLANING / REMOVAL
	DITCH		NOTE		DATE		INFORMATION AVAILABLE. BUT NO GUARANTEE IS GIVEN THAT ALL EXISTING UTILITIES ARE SHOWN OR THAT THE GIVEN LOCATIONS ARE EXACT. CONFIRMATION OF EXISTENCE AND EXACT LOCATION OF ALL SERVICES MUST BE OBTAINED FROM THE INDIVIDUAL UTILITIES BEFORE PROCEEDING WITH CONSTRUCTION.		PLANING / REMOVAL

**LOCATION APPROVED**  
UNDERGROUND STRUCTURES

DATE: 14/06/25

BY: RPB

No.	ISSUED FOR CONSTRUCTION	DATE	BY
0	ISSUED FOR CONSTRUCTION	14/06/25	RPB
	REVISIONS	YYMMDD	

**MORRISON HERSHFIELD**

DESIGNED BY: RPB  
CHECKED BY: WRJ  
DRAWN BY: DID/DML  
APPROVED BY: BWB

HOR. SCALE: 1:250  
VERT. SCALE: 1:10  
DATE: 14/06/25

PROFESSIONAL'S SEAL

PROVINCE OF MANITOBA  
R.P. BRUCE  
REGISTERED PROFESSIONAL ENGINEER

CONSULTANT DRAWING No. W140002-T-003\_RX.dwg

**THE CITY OF WINNIPEG**  
PUBLIC WORKS DEPARTMENT  
ENGINEERING DIVISION

2014 LOCAL STREETS PACKAGE  
DUNROBIN AVENUE  
WATT STREET TO GOLSPIE STREET  
ASPHALT RECONSTRUCTION  
HORIZONTAL AND VERTICAL ALIGNMENT  
STA 0+350 TO STA 0+490

CITY DRAWING NUMBER: N/A  
SHEET 3 OF 20  
DRAWING No. 3  
REV 0