

A1 SIZE 894mm x 841mm

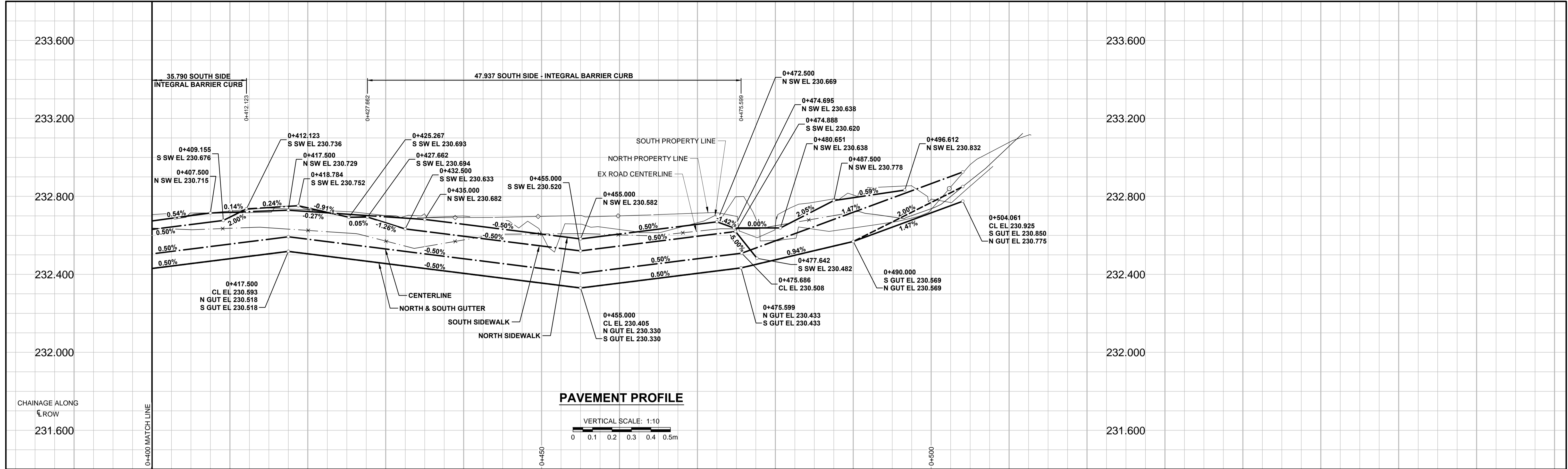

PLOT: 6277/2014.10.38.24.AM

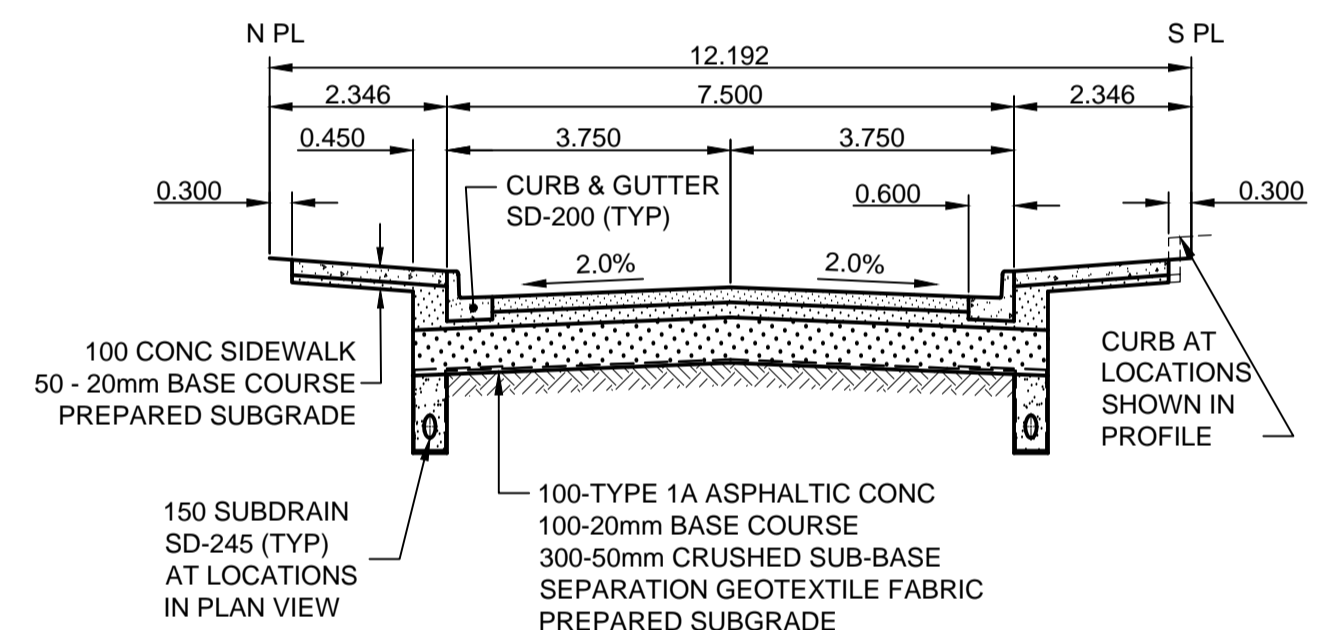
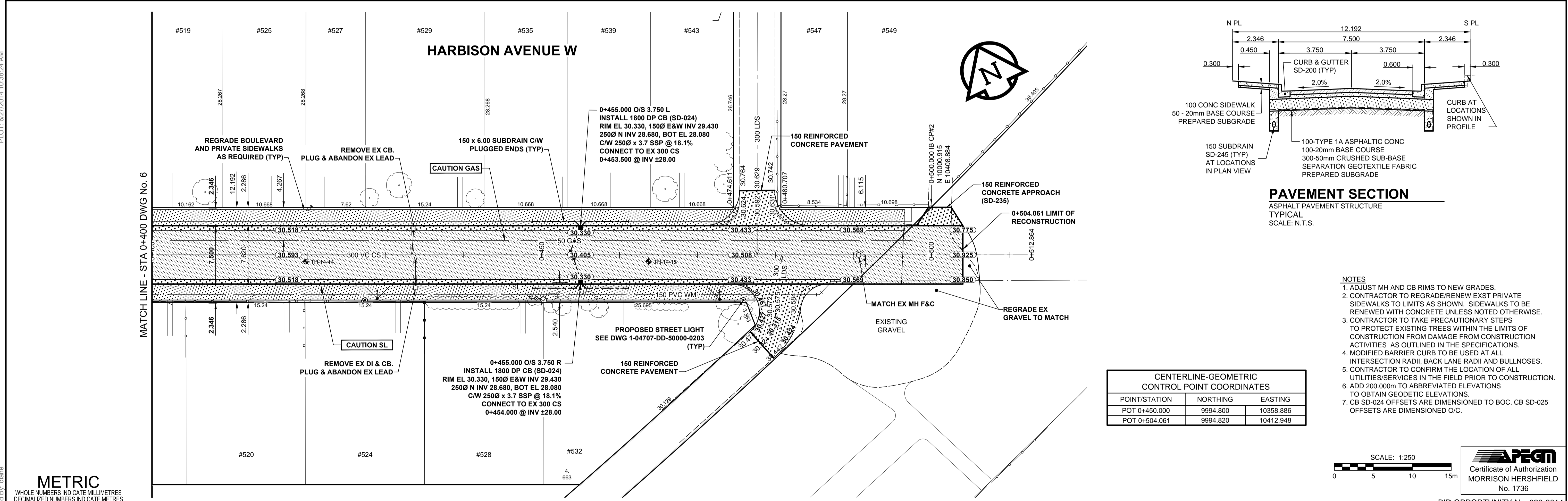

PAVEMENT SECTION
ASPHALT PAVEMENT STRUCTURE
TYPICAL
SCALE: N.T.S.

- NOTES**
- ADJUST MH AND CB RIMS TO NEW GRADES.
 - CONTRACTOR TO REGRADE/RENEW EXST PRIVATE SIDEWALKS TO LIMITS AS SHOWN. SIDEWALKS TO BE RENEWED WITH CONCRETE UNLESS NOTED OTHERWISE.
 - CONTRACTOR TO TAKE PRECAUTIONARY STEPS TO PROTECT EXISTING TREES WITHIN THE LIMITS OF CONSTRUCTION FROM DAMAGE FROM CONSTRUCTION ACTIVITIES AS OUTLINED IN THE SPECIFICATIONS.
 - MODIFIED BARRIER CURB TO BE USED AT ALL INTERSECTION RADII, BACK LANE RADII AND BULLNOSES.
 - CONTRACTOR TO CONFIRM THE LOCATION OF ALL UTILITIES/SERVICES IN THE FIELD PRIOR TO CONSTRUCTION.
 - ADD 200.000m TO ABBREVIATED ELEVATIONS TO OBTAIN GEODETIC ELEVATIONS.
 - CB SD-024 OFFSETS ARE DIMENSIONED TO BOC. CB SD-025 OFFSETS ARE DIMENSIONED O/C.

CENTERLINE-GEOMETRIC CONTROL POINT COORDINATES		
POINT/STATION	NORTHING	EASTING
POT 0+450.000	9994.800	10358.886
POT 0+504.061	9994.820	10412.948

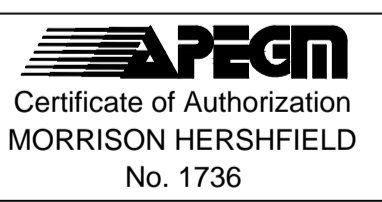
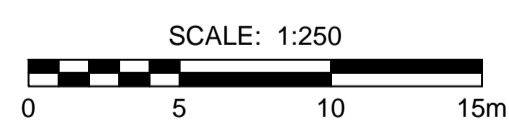

BID OPPORTUNITY No. 622-2014

METRIC
WHOLE NUMBERS INDICATE MILLIMETRES
DECIMALIZE NUMBERS INDICATE METRES

EXISTING	LEGEND - PLAN	NEW	EXISTING	LEGEND - PLAN	NEW	EXISTING	LEGEND - PLAN	NEW	
	GAS		MANHOLE		CONCRETE PAVEMENT		LOCATION APPROVED		CONC SIDEWALK / MEDIAN
	MTS		CATCH BASIN / CATCH PIT		ASPHALT PAVEMENT		SUPR. UG STRUCTURES		RAMP CURBS
	HYDRO		CURB INLET WITH BOX		PAVING STONE		DATE COMMITTEE		PLANING / REMOVAL
	CATV / FIBRE OPTIC		TREE		GRAVEL		NOTE:		
	TRAFFIC SIGNALS / PIT		TEST HOLE		PROPERTY LINE		LOCATION APPROVED		
	LAND DRAINAGE SEWER		SURVEY BAR		FENCE		NOTE:		
	SANITARY/COMBINED SEWER		BOC / EDGE OF PAVEMENT		ELEVATION		NOTE:		
	SEWER SERV/DRAINAGE CONN		TRAFFIC SIGN		ELEVATION		NOTE:		
	WATERMAIN								
	SUBDRAIN								
	DITCH								

LOCATION APPROVED
UNDERGROUND STRUCTURES

SUPR. UG STRUCTURES DATE COMMITTEE

NOTE:
LOCATION OF UNDERGROUND STRUCTURES AS SHOWN ARE BASED ON THE BEST INFORMATION AVAILABLE. BUT NO GUARANTEE IS GIVEN THAT ALL EXISTING UTILITIES ARE SHOWN OR THAT THE GIVEN LOCATIONS ARE EXACT. CONFIRMATION OF EXISTENCE AND EXACT LOCATION OF ALL SERVICES MUST BE OBTAINED FROM THE INDIVIDUAL UTILITIES BEFORE PROCEEDING WITH CONSTRUCTION.

GBM 27-030 ELEV 230.897			
0	ISSUED FOR CONSTRUCTION	14/06/26	JGK
No.	REVISIONS	YYMMDDI	BY

MORRISON HERSHFIELD	
DESIGNED BY	JGK
CHECKED BY	RPB
DRAWN BY	DID/DML
APPROVED BY	BWB
HOR. SCALE	1:250
VERT. SCALE	1:10
DATE	14/06/25

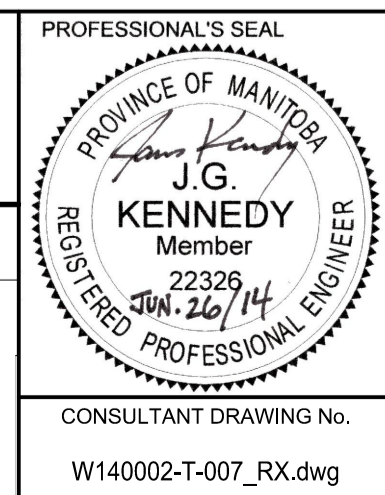

THE CITY OF WINNIPEG
PUBLIC WORKS DEPARTMENT
ENGINEERING DIVISION

2014 LOCAL STREETS PACKAGE
HARBISON AVENUE W
WATT STREET TO EAST END
ASPHALT RECONSTRUCTION
HORIZONTAL AND VERTICAL ALIGNMENT
STA 0+400 TO STA 0+520

CITY DRAWING NUMBER	N/A
SHEET	7 OF 20
DRAWING No.	7
REV	0

FILE NAME: W140002-T-007_RX.dwg Saved By: diane